

S c a n P l u s **Installation Guide**

Edition 1.2

SP/XX/IG/12/E/980228

Notice

The ScanPlus products described in this manual comply with CE directives for electromagnetic emission levels and electrical immunity.

The information contained in this manual is for informational purposes only and is subject to change without notice. No part of this manual may be copied or reproduced in any manner without the prior written permission of United Barcode Industries.

ScanPlus products are covered by patents issued or pending in the USA and other countries. ScanPlus is a trademark of United Barcode Industries.

This Installation Guide can be used with all ScanPlus products except the ScanPlus CL.
--



Scanner Technology Center

DECLARATION OF CONFORMITY

We,

UBI Scanner Technology Center
Immeuble Le Naurouze, Rue Carmin
Voie No.3, Innopole - BP 187
31676 Labège Cedex
France

declare under our sole responsibility¹ that the product(s)

ScanPlus SP / ER / XP / PDF
Cable Management Modules

to which this declaration relates

is (are) in conformity with the following standards:

Emission: EN 50081-1 (1992)
EN 55022 (1987) Class B
Immunity: EN 50082-1 (1992)
IEC 801-2 (1984 -91) 8kV in the air
IEC 801-3 (1984) 3 V/m
IEC 801-4 (1988) 1kV
Low voltage: EN 60950 (1993)

following the provisions of Directives

89/336/EEC
73/23/EEC

Toulouse 30/11/1996

.....
Sven Skarendahl
President

¹UBI assumes no responsibility as regards fulfilling the CE Directive if the product(s) is (are) handled, modified or installed in other manners than those described in UBI's manuals.

UBI Scanner Technology Center
Immeuble Le Naurouze, Rue Carmin
Voie No.3, Innopole - BP 187, 31676 Labège Cedex, France
Tel: +33 (0)5 61 39 98 58 • Fax: +33 (0)5 61 39 20 00

What you are going to do . . .

This Installation Guide tells you how to install and set up your ScanPlus to operate successfully in most working situations.

The present guide does not cover all the configuration capabilities of your ScanPlus. The full set of configuration options is provided in the *ScanPlus Reference Manual*.

Step by step how to install and set up your ScanPlus

- 1 Check you have everything you need..... 1-1
- 2 Switch off the host system and connect up the ScanPlus 2-1
- 3 Switch on the host system 3-1
- 4 Enter the interface number for your host system 4-1
- 5 Set up the data transmission parameters..... 5-1
- 6 Set up the symbology parameters 6-1
- 7 Set up the operating parameters—Activate the pushbutton 7-1

Additional information is provided in the Appendix

- A Pin assignments—Single-output RS-232 CMMA-1
- B Jumper settings—Dual-output RS-232 CMM.....B-1
- C If you have a problemC-1
- D Test codesD-1

What you are going to do . . .

1

Check you have everything you need

Checklist of items for your installation

- all systems**
- the right ScanPlus model
 - this *ScanPlus Installation Guide*
 - ScanPlus user's leaflet if applicable
- options**
- external power supply
 - keyboard wedge CMM and associated keyboard/system cables
 - single-output or dual-output RS-232 CMM and associated cables if applicable
 - ScanPlus Reference Manual*

<i>external power supply</i>	5V or 12V mains power supply adapter—necessary if the host system does not provide enough electrical power to drive the ScanPlus
<i>keyboard wedge</i>	ScanPlus connected between a keyboard and the host system—data from the ScanPlus is transmitted in keyboard emulation mode to provide instant software compatibility (an external power supply may be necessary)
<i>CMM</i>	Cable Management Module—cable adapter used to connect the ScanPlus to the host system if a direct connection is not possible (some keyboard wedge configurations, need for an external power supply, ...)
<i>single-output RS-232 CMM</i>	CMM for RS-232 configuration with external power supply
<i>dual-output RS-232 CMM</i>	CMM for ScanPlus connected between two systems communicating through an RS-232 link (external power supply necessary)

1. Check you have everything you need

2

Switch off the host system and connect up the ScanPlus

Direct connection or Cable Management Module (CMM) ?

Depending on your system configuration, you will either be able to connect your ScanPlus directly to the host system or you will need to use a CMM cable adapter.

Host interfaces

Keyboard wedge—ScanPlus with Y cable (PC AT and compatible)	2-2
Keyboard wedge—CMM and external power supply (if required)	2-3
RS-232—Direct connection	2-4
RS-232—Single-output CMM and external power supply.....	2-4
RS-232—Dual-output CMM and external power supply	2-5
IBM 46xx cash registers.....	2-6
OCIA cash registers	2-6
Laser emulation.....	2-7
Wand emulation.....	2-7

2. Switch off the host system and connect up the ScanPlus

Keyboard wedge—ScanPlus with Y cable (PC AT and compatible)

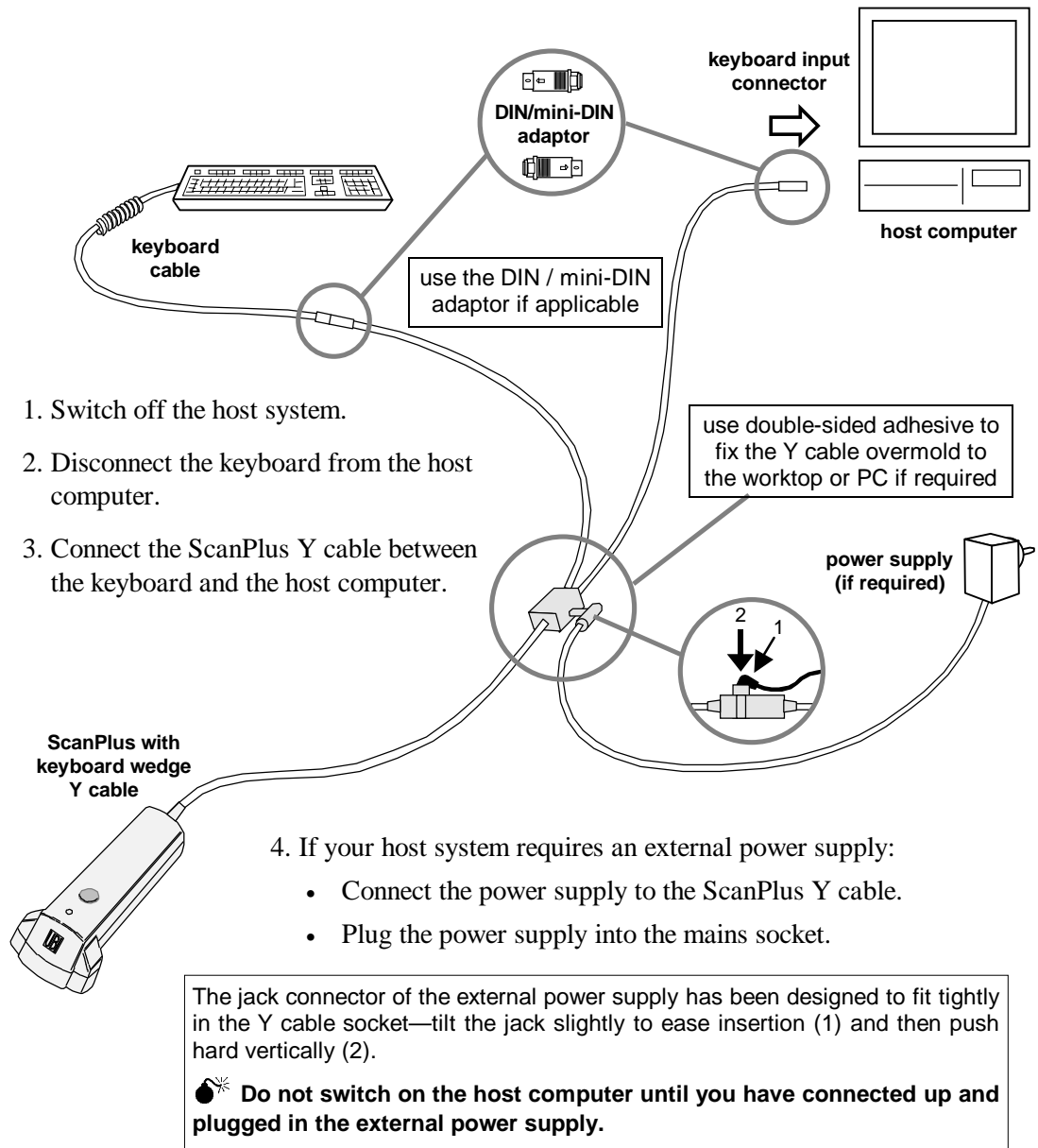

2. Switch off the host system and connect up the ScanPlus

Keyboard wedge—CMM and external power supply (if required)

1. Switch off the host system.
2. Disconnect the keyboard from the host computer.

3. Use the appropriate keyboard wedge cables to connect the wedge CMM between the keyboard and the host computer.

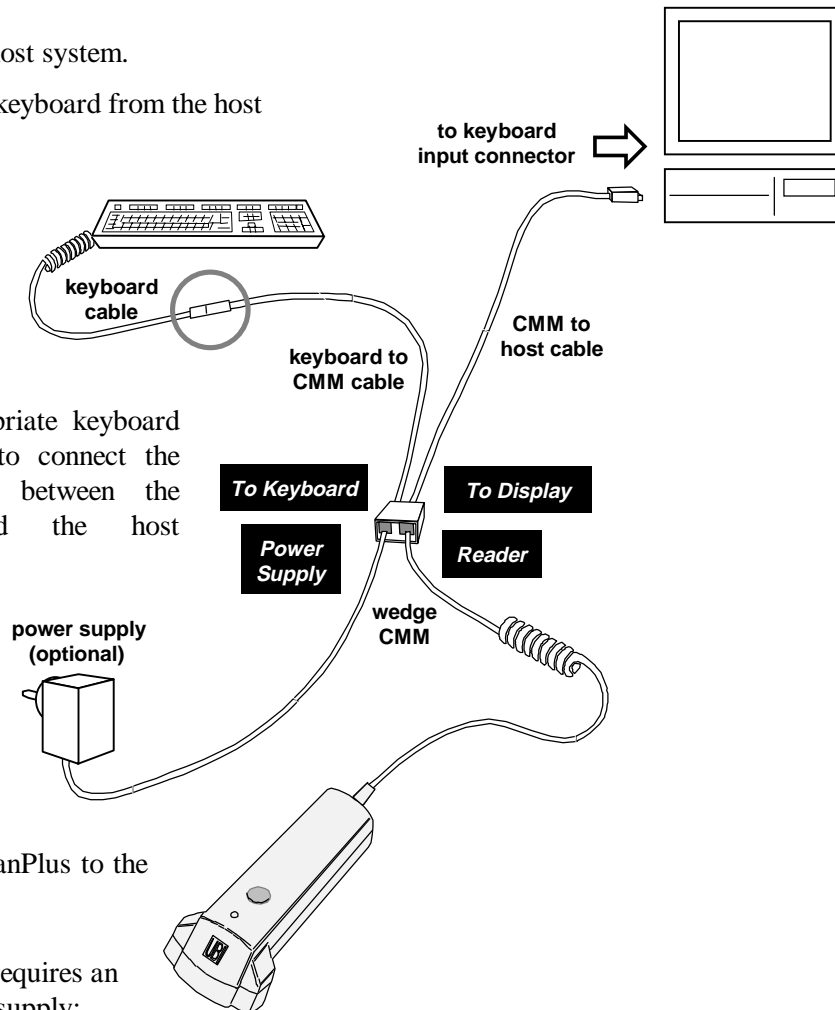

4. Connect the ScanPlus to the wedge CMM.
5. If your system requires an external power supply:
 - Connect the power supply to the wedge CMM.
 - Plug the power supply into the mains socket.

⚡ Do not switch on the host computer until you have connected up and plugged in the external power supply.

2. Switch off the host system and connect up the ScanPlus

RS-232—Direct connection

1. Switch off the host system.
2. Connect the ScanPlus to the host computer.

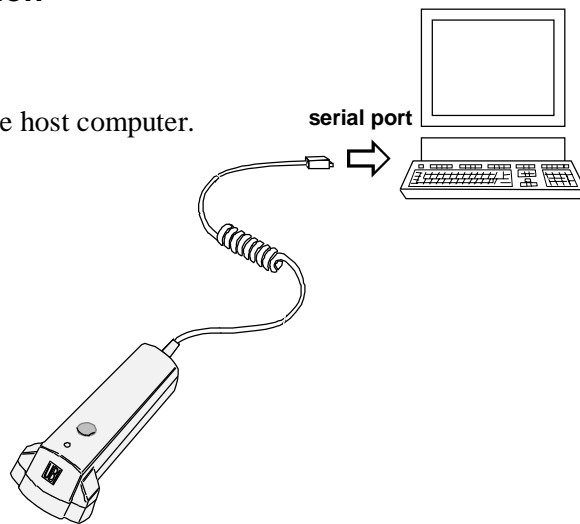

RS-232—Single-output CMM and external power supply

1. Switch off the host system.
2. Use the single-output RS-232 CMM to connect the ScanPlus to the host computer.

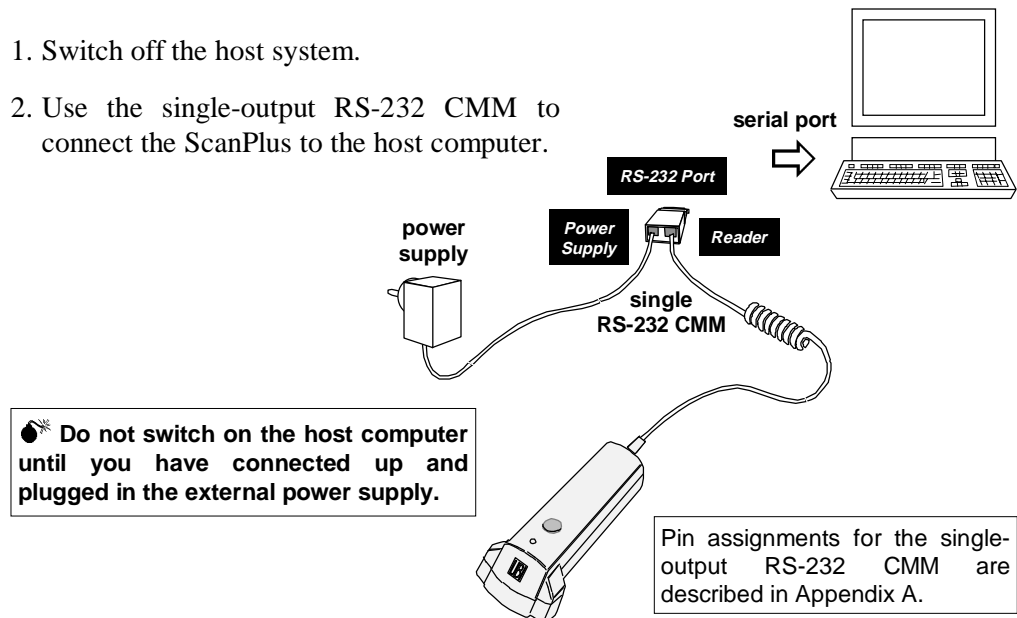

2. Switch off the host system and connect up the ScanPlus

RS-232—Dual-output CMM and external power supply

1. Switch off the host system.
2. Use the dual-output RS-232 CMM to connect the ScanPlus between the terminal and the host computer.

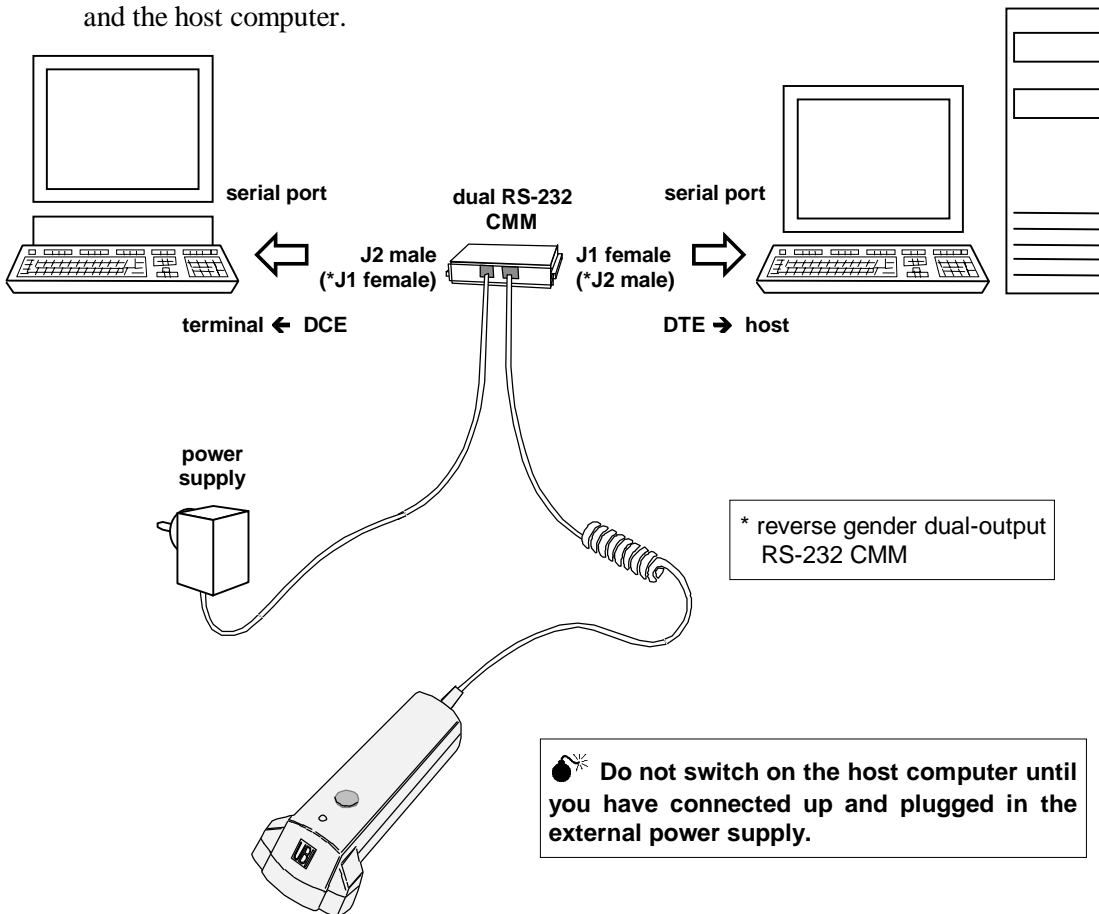

By default, dual-output RS-232 CMMs for the ScanPlus are configured for data transmission on the DTE connector (to host) only.

By modifying internal jumper settings, the dual-output RS-232 CMM can be set to transmit data on the DCE connector (to terminal) only or on both DTE and DCE—see Appendix B.

2. Switch off the host system and connect up the ScanPlus

IBM 46xx cash registers

1. Switch off the host system.
2. Connect the ScanPlus to the cash register.

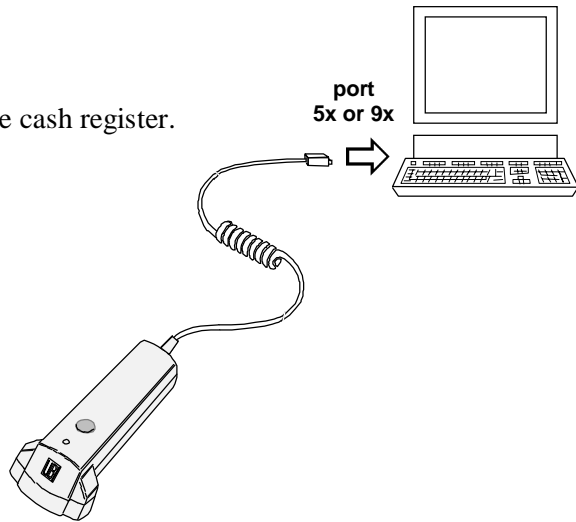

OCIA cash registers

1. Switch off the host system.
2. Connect the ScanPlus to the cash register.

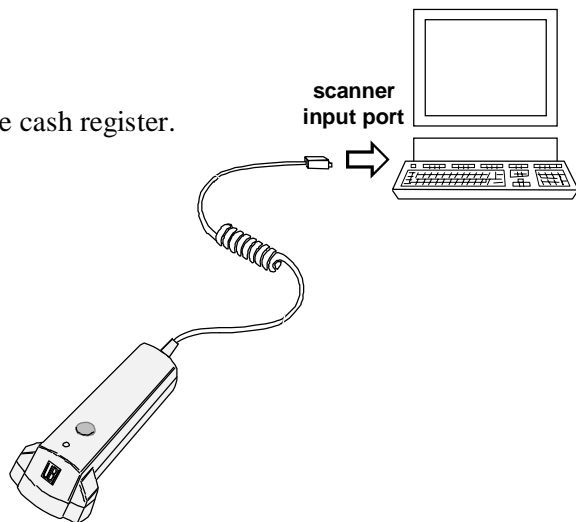

2. Switch off the host system and connect up the ScanPlus

Laser emulation

1. Switch off the host system.
2. Connect the ScanPlus to the host computer.

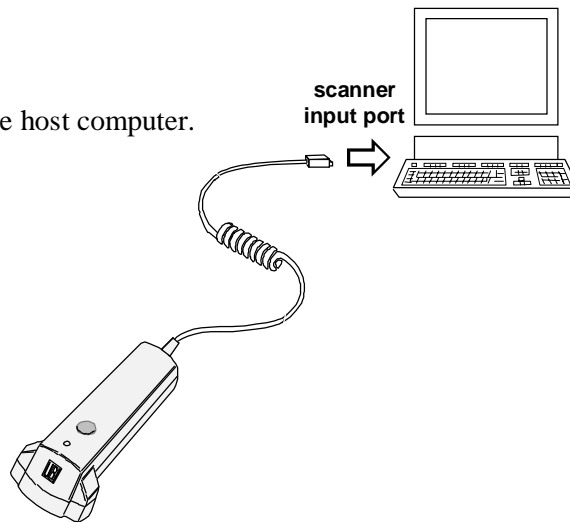

Wand emulation

1. Switch off the host system.
2. Connect the ScanPlus to the host computer.

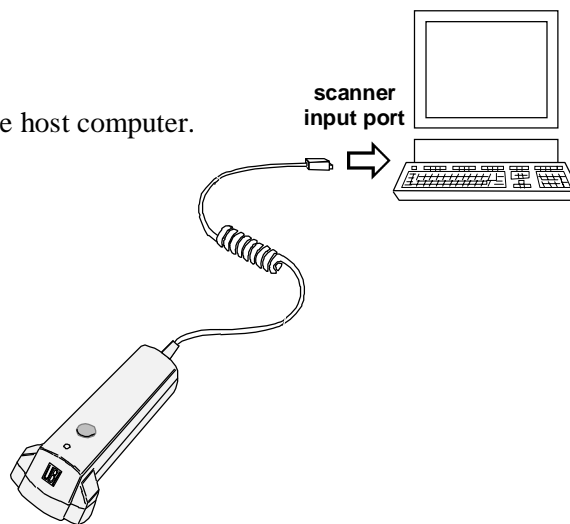

2. Switch off the host system and connect up the ScanPlus

3

Switch on the host system

What the beeps and LED flashes mean

The ScanPlus should emit two beeps to indicate that the power-up sequence has been completed.

The green indicator LED will then indicate the interface type selected for the ScanPlus.

green LED indication	selected interface type	P/N identification
continuous LED	null interface	factory default setting (all models)
no LED	laser emulation	x - x x x x x 0 - x x - x x
1 flash	wand emulation	x - x x x x x 1 - x x - x x
2 flashes	RS-232 C	x - x x x x x 2 - x x - x x
3 flashes	IBM 46xx cash registers	x - x x x x x 3 - x x - x x
4 flashes	RS-232 TTL	x - x x x x x 4 - x x - x x
5 flashes	OCIA cash registers	x - x x x x x 5 - x x - x x
7 flashes	keyboard wedge	x - x x x x x 7 - x x - x x

The Part Number (P/N) indicates the hardware interface setup for your ScanPlus model.

If you have an energy saver pushbutton model and the pushbutton is activated, the power-up beeps and power-up LED will not operate.

3. Switch on the host system

4

Enter the interface number for your host system

<i>interface number</i>	automatically configures your ScanPlus by setting interface-specific parameters—in particular data transmission parameters—to suit your operating environment
-------------------------	---

Using your ScanPlus

You are going to use your ScanPlus to read some of the configuration bar codes provided in this Installation Guide.

The ScanPlus has special beeps for configuration bar codes:

- two beeps indicate that the ScanPlus has successfully read the configuration code and saved the setting,
- six short beeps indicate a setup error (incorrect configuration code) for the selected interface type.

If you have any problems reading the configuration codes, refer to Appendix C for help.

For full details on how to use your ScanPlus, see the user's leaflet for your ScanPlus product if applicable.

Configuration codes with an asterisk (*) are factory default settings.

4. Enter the interface number for your host system

Which interface number?

1. Look on the next pages to see if there is a predefined interface number for your host system hardware configuration:

Keyboard wedge.....	4-3
RS-232.....	4-7
Laser emulation.....	4-8
Wand emulation	4-8
IBM 46xx cash registers.....	4-9
OCIA cash registers	4-9

2. If you find a number for your hardware configuration, use your ScanPlus to read the corresponding bar code.

If you do not find an interface number for your host system configuration . . .

If your interface number is not among the predefined interface numbers provided below, you must compose the number yourself.

If you do not know which number to enter, contact your UBI representative.

1. Use your ScanPlus to read the Compose Interface Number bar code:

Compose Interface Number



2. Read each digit of your interface number using the number codes on the back cover of this Installation Guide and scan the End Selection bar code—also on the back cover—to finish.

Example To enter the number 102:

1. Scan Compose Interface Number.
2. Scan 1, then 0, then 2.
3. Scan End Selection.

4. Enter the interface number for your host system

Keyboard wedge

IBM PC AT and compatible

N° 200 - QWERTY - English



N° 201 - AZERTY - French



N° 204 - QWERTZ - German

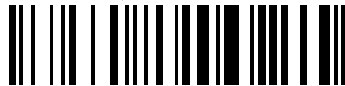

N° 205 - QWERTY - Swedish / Finnish



N° 206 - QWERTY - Italian



N° 207 - QWERTY - Norwegian

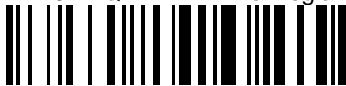

N° 208 - QWERTY - Danish



N° 209 - QWERTY - Spanish



N° 2020 - QWERTZ - Swiss / French



4. Enter the interface number for your host system

Keyboard wedge

IBM 31xx, 32xx, 34xx

N° 230 - QWERTY - English

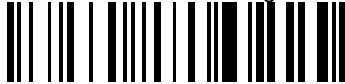

N° 231 - AZERTY - French



N° 232 - AZERTY - international

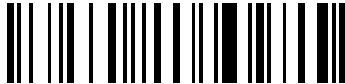

N° 233 - AZERTY - caps QWERTY

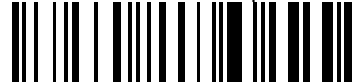

N° 234 - QWERTZ - German



N° 2310 - QWERTY - data entry



N° 2313 - AZERTY - data entry



N° 2314 - QWERTZ - numeric keypad



4. Enter the interface number for your host system

Keyboard wedge

DEC VT 220, 320, 420

N° 411 - AZERTY - PC type



N° 410 - QWERTY - PC type

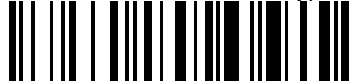

N° 414 - QWERTZ - PC type

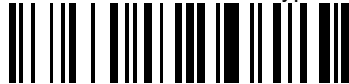

N° 415 - QWERTY - PC type - Swedish / Finnish



DEC VT/PC 510

N° 271 - AZERTY - PC type



N° 275 - QWERTY - PC type - Swedish / Finnish



N° 2717 - AZERTY - VT type - French

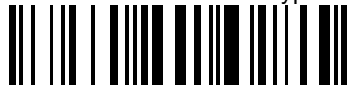

N° 2718 - QWERTY - VT type - Swedish / Finnish



N° 2720 - QWERTZ - PC type - Swiss / French



4. Enter the interface number for your host system

Keyboard wedge

Apple / Macintosh

N° 220 - QWERTY - English



N° 221 - AZERTY - French



N° 224 - QWERTZ - German



Hewlett Packard 700/92

N° 260 - QWERTY - English



N° 261 - AZERTY - French



N° 264 - QWERTZ - German



Wyse 60, 65, 99GT, 120

N° 300 - QWERTY 102 keys PC/AT fast



N° 301 - AZERTY 102 keys PC/AT fast



N° 304 - QWERTZ 102 keys PC/AT fast



4. Enter the interface number for your host system

RS-232

N° 100 - Standard RS-232 C (9600, 7, E, 2)



N° 101 - RS-232 TTL Level



N° 102 - RS-232 PC Term



N° 103 - RS-232 Compatible ScanPlus CL Slave Mode



N° 105 - RS-232 Slave Mode



4. Enter the interface number for your host system

Laser emulation

N° 132 - Laser With Pushbutton

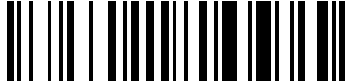

N° 134 - Connection to MicroBar LS



Wand emulation

N° 130 - Digital Wand Emulation

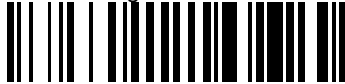

N° 131 - Analog Wand Emulation–Intermec Interface



Read N° 131 - Analog Wand Emulation–Intermec Interface if you want to use the following ScanPlus products:

- ScanPlus SP - P/N 0-320311-11
- ScanPlus ER - P/N 0-330311-11
- ScanPlus XP - P/N 0-340311-11
- wand cable for all three products – P/N 0-332097-01

in wand emulation with the following Intermec products (white high):

- 97XX wedge products
- JANUS™ 2010 hand-held computers
- TRAKKER® Antares™ 242X terminals

4. Enter the interface number for your host system

IBM 46xx cash registers

N° 110 - IBM 46xx cash registers—Port 9x



N° 111 - IBM 46xx cash registers—Port 5x



OCIA cash registers

N° 120 - OCIA TEC cash registers - First Type



N° 121 - OCIA TEC cash registers - Second Type



N° 122 - OCIA NCR cash registers



4. Enter the interface number for your host system

5

Set up the data transmission parameters

data transmission parameters interface-specific communication parameters—in certain cases they need to be modified to optimize the performance of the ScanPlus

Scanning the interface number automatically configures your ScanPlus to suit your operating environment by modifying the settings for data transmission to the host system.

This section lists the data transmission parameter settings for all the host systems supported and provides some common data transmission options for output to keyboard wedge and RS-232 host systems—use your ScanPlus to read the configuration codes if required.

The full set of data transmission parameter options for all the host system interfaces supported is provided in the *ScanPlus Reference Manual*.

Keep a list of your custom settings—this will be useful if you have to perform a reset.

Resetting the predefined data transmission settings

If you want to reset all the predefined data transmission settings for your host system, rescan the appropriate host system interface number (see section 4, *Enter the interface number for your host system*).

Selecting the interface number usually only modifies data transmission settings, but in some special cases, other parameter settings—pushbutton activation, beep/indicator LED settings, symbology settings—may be modified for specific interface configurations.

5. Set up the data transmission parameters

Keyboard wedge

An asterisk (*) indicates the predefined parameter settings for keyboard wedge interface N° 200 (QWERTY - English).

Inter-character delay

No Delay (*)



20 ms



Postamble

Enter (*)



Carriage Return



Tab



Field Advance



Field Exit



No Postamble



5. Set up the data transmission parameters

Keyboard wedge

Additional parameters—*ScanPlus Reference Manual*

- preamble - no preamble (*)
 - user-defined
- postamble - Down Arrow
 - user-defined
- "code mark" symbology identifiers - not transmitted (*)
 - transmitted
 - default / user-defined
- AIM symbology identifiers - not transmitted (*)
 - transmitted
- special keys interpretation (Code 39) - not active (*)
 - always active
 - only active if separate 2-character label or if preceded by a hyphen (-)
 - only active if separate 2-character label
- special keys transmission - control characters on (*)
 - control characters off
 - Alt mode off (*)
 - Alt mode on
- end-of-transmission keyboard character status - lower case (*)
 - upper case
- inter-character delay - 10 - 30 - 40 - 50 ms
 - user-defined 1 to 999 ms
- inter-message delay - none (*)
 - 10 - 30 - 50 - 80 - 100 ms
 - user-defined 1 to 999 ms

5. Set up the data transmission parameters

RS-232

An asterisk (*) indicates the predefined parameter settings for interface N° 100 (Standard RS-232 C).

Baud Rate



Data bits



Parity



Stop bits



5. Set up the data transmission parameters

RS-232

RTS/CTS hardware protocol

Not Active (*)



Active



Inter-character delay

No Delay (*)

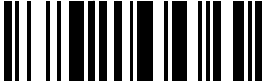

10 ms



Postamble

Carriage Return + Line Feed (*)



Carriage Return



Line Feed



No Postamble



5. Set up the data transmission parameters

RS-232

Additional parameters—*ScanPlus Reference Manual*

baud rate	- 75 - 150 - 300 - 600 - 1200 - 2400 - 4800 - 38400
hardware/software protocols timeout	- 1000 ms (*) - unlimited - user-defined 1 to 2500 ms
ENQ (Hex 05)	- not used (*) - ENQ (HEX 05) - user-defined
ACK (Hex 06)	- not used (*) - ACK (HEX 06) - user-defined
NAK (Hex 15)	- not used (*) - NAK (HEX 15) - user-defined
XON/XOFF software protocol	- not active (*) - active
LRC (longitudinal redundancy check)	- not active (*) - active
preamble	- no preamble - user-defined
postamble	- user-defined
"code mark" symbology identifiers	- not transmitted (*) - transmitted - default / user-defined
AIM symbology identifiers	- not transmitted (*) - transmitted
inter-character delay	- 20 - 30 - 40 - 50 ms - user-defined 1 to 999 ms
inter-message delay	- none (*) - 10 - 30 - 50 - 80 - 100 ms - user-defined 1 to 999 ms

5. Set up the data transmission parameters

Laser emulation

Additional parameters—*ScanPlus Reference Manual*

An asterisk (*) indicates the predefined parameter settings for interface N° 132 (laser with pushbutton).

- transmitted symbology type
 - transmission in original code (*)
 - transmission in Code 39
- inter-message delay
 - none (*)
 - 1 to 999 ms
- margin size
 - 10 x narrow bar width (*)
 - user-defined
- logical signal state during transmission
 - bar = 1, space = 0, margin = 0 (*)
 - bar = 0, space = 1, margin = 1
- logical signal state outside transmission
 - quiet zone = 1 (*)
 - quiet zone = 0

Wand emulation

Additional parameters—*ScanPlus Reference Manual*

An asterisk (*) indicates the predefined parameter settings for interface N° 130 (digital wand emulation).

- transmitted symbology type
 - transmission in original code (*)
 - transmission in Code 39
- inter-message delay
 - none (*)
 - 1 to 999 ms
- margin size
 - 10 x narrow bar width (*)
 - user-defined
- logical signal state during transmission
 - bar = 1, space = 0, margin = 0 (*)
 - bar = 0, space = 1, margin = 1
- logical signal state outside transmission
 - quiet zone = 0 (*)
 - quiet zone = 1
- pulse duration
 - 0.88 ms (37.5 cm/s) (*)
 - 0.19 ms (175 cm/s) - 0.26 ms (125 cm/s) -
 - 0.44 ms (75 cm/s) - 0.66 ms (50 cm/s) -
 - 1.32 ms (25 cm/s) - 2.64 ms (12.5 cm/s) -
 - 6.60 ms (5 cm/s)

5. Set up the data transmission parameters

IBM 46xx cash registers

Additional parameters—*ScanPlus Reference Manual*

The main predefined parameter settings for IBM 46xx cash registers depend on cash register protocols and can not be modified.

An asterisk (*) indicates the predefined transmission delay setting for interface N° 110 / N° 111 (IBM 46xx cash registers—Port 9x / Port 5x).

inter-message delay - none (*)
- 1 to 999 ms

OCIA cash registers

Additional parameters—*ScanPlus Reference Manual*

The main predefined parameter settings for OCIA cash registers depend on cash register protocols and can not be modified.

An asterisk (*) indicates the predefined transmission delay settings for interface N° 120 / N° 121 / N° 122 (OCIA cash registers—TEC First Type / TEC Second Type / NCR).

inter-character delay - none (*)
- 1 to 999 ms
inter-message delay - none (*)
- 1 to 999 ms

6

Set up the symbology parameters

<i>symbology</i>	barcode type or "family"—Code 39, UPC and EAN are examples of common symbologies
------------------	--

Symbologies and symbology parameters

The ScanPlus supports all the most common symbologies. Depending on your ScanPlus model, certain symbologies are already selected by default:

ScanPlus SP / ER / XP	- Code 39, UPC/EAN code families
ScanPlus PDF	- PDF417

This section provides the different symbology activation codes and some common parameter settings—if you want to select different symbologies or modify the parameter settings, use your ScanPlus to read the corresponding bar codes.

The full set of symbology parameter options is provided in the <i>ScanPlus Reference Manual</i> (→ <i>Symbologies</i>).
--

6. Set up the symbology parameters

Symbology default settings

When you install your ScanPlus for the first time, Code 39 and UPC/EAN (ScanPlus SP / ER / XP) or PDF417 (ScanPlus PDF) are preselected by default and all the symbology parameters are set to their factory default settings.

The symbology default settings are global factory defaults—they are independent of the different symbology activation codes.

Factory default settings are indicated by an asterisk (*).

Resetting symbology default settings

If you want to reset all the default symbology settings, you can scan the Reset Factory Defaults bar code provided in Appendix C, but you will then have to completely reconfigure your ScanPlus.

In most cases, it is easier to perform the following symbology reset procedure.

1. Scan the Disable All Symbologies bar code:

Disable All Symbologies



2. Select the activation codes for the symbologies you want to read.
3. Customize the symbology parameter settings if required.

The Disable All Symbologies code deactivates all the symbologies activated. If you want to deactivate individual symbologies, use the Not Active codes for each symbology.

Disable All Symbologies does not reset the individual parameter settings for each symbology. When you reactivate a symbology, you recover the parameter settings stored in memory for that symbology when it was disabled.

6. Set up the symbology parameters

Symbology activation codes and common parameter settings

All symbologies are available with all ScanPlus models unless otherwise specified.

To optimize the performance of your ScanPlus and to ensure trouble-free scanning, do not select symbologies that you do not need—deactivate the Code 39 and UPC/EAN default symbologies if you do not need to use them.

Keep a list of your custom settings—this will be useful if you have to perform a reset.

Codabar	6-4
Codablock	6-6
Code 39	6-7
Code 93	6-10
Code 128 / EAN 128.....	6-11
Interleaved 2 of 5.....	6-13
Matrix 2 of 5	6-15
MSI Code.....	6-16
PDF417.....	6-17
Plessey Code	6-18
Standard 2 of 5	6-19
UPC/EAN code families (UPC-A, UPC-E, EAN-8, EAN-13)	6-21

6. Set up the symbology parameters

Codabar

Activation

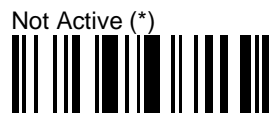

Start/stop

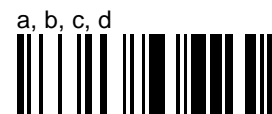

Barcode length

The minimum length possible for Codabar is 3 characters:

[start + barcode data + check digit if applicable + stop]

For maximum security, we recommend that you use one of the following parameters with all ScanPlus products:

- **Compose 1 or 2 Fixed Lengths (the safest configuration),**
- **Compose Minimum Length.**

Compose 1 or 2 Fixed Lengths provides the best security if the codes in your application have fixed lengths.

Compose Minimum Length is recommended if the codes in your application do not have fixed lengths.

Use the special number codes provided on the back cover of this Installation Guide and scan End Selection once or twice as required.

6. Set up the symbology parameters

Codabar

Barcode length

Compose 1 or 2 Fixed Lengths



1 fixed length: Compose 1 or 2 Fixed Lengths
<length>—End Selection—End Selection

2 fixed lengths: Compose 1 or 2 Fixed Lengths
<first length>—End Selection
<second length>—End Selection—End Selection

Compose Minimum Length (default = 6)



minimum length: Compose Minimum Length
<length>—End Selection

Additional parameters—*ScanPlus Reference Manual*

- start/stop
 - A, B, C, D
 - a, b, c, d / t, n, *, e
 - DC1, DC2, DC3, DC4
- CLSI library system
 - not active (*)
 - active
- check digit (AIM recommendation)
 - not used (*)
 - checked and transmitted
 - checked but not transmitted
- barcode length (number of characters)
 - minimum length = 6 (*)
 - any length

6. Set up the symbology parameters

Codablock

Activation

Codablock is only available with the ScanPlus XP and ScanPlus PDF.

Select the desired Codablock format and scan Active to enable.

Not Active (*)



Active



Codablock F (*)



Codablock A



Check digit

Not Transmitted (*)



Transmitted



Additional parameters—*ScanPlus Reference Manual*

- time-out between reads - active (*)
- not active

6. Set up the symbology parameters

Code 39

Activation

Active (*) (ScanPlus SP / ER / XP)



Not Active (*) (ScanPlus PDF)



Standard 43 Characters (*)



Full ASCII



Start/stop

Not Transmitted (*)



Transmitted



Check digit

Check Digit Not Used (*)



6. Set up the symbology parameters

Code 39

Check digit

French CIP Check Digit - Checked And Transmitted



French CIP Check Digit - Checked But Not Transmitted



Italian CPI Check Digit - Checked And Transmitted



Italian CPI Check Digit - Checked But Not Transmitted



Barcode length

The minimum length possible for Code 39 is 3 characters:

[start + barcode data + check digit if applicable + stop]

Compose Minimum Length is recommended if you know the minimum length of the codes in your application (especially recommended for the ScanPlus ER).

Use the special number codes provided on the back cover of this Installation Guide and scan End Selection.

Compose Minimum Length (default = any length)



minimum length: Compose Minimum Length
<length>—End Selection

6. Set up the symbology parameters

Code 39

Additional parameters—*ScanPlus Reference Manual*

- accepted start/stop characters
 - " * " only (*)
 - " \$ " only
 - " \$ " and " * " accepted
- modulo 43 check digit
 - checked and transmitted
 - checked but not transmitted
- barcode length (number of characters)
 - any length (*)
 - minimum length = 6
- special keys interpretation (keyboard wedge)
 - not active (*)
 - always active
 - only active if separate 2-character label or if preceded by a hyphen (-)
 - only active if separate 2-character label

6. Set up the symbology parameters

Code 93

Activation

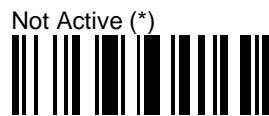

Additional parameters—*ScanPlus Reference Manual*

- barcode length (number of characters) - any length (*)
- minimum length = 6
 - minimum length—user-defined

6. Set up the symbology parameters

Code 128 / EAN 128

New normalization allows decoding of the UCC/EAN standard extension. EAN 128 is auto-discriminating with Code 128 (recognition of the FNC1 start character used).

Activation

Not Active (*)



Active



EAN 128 identifier

The]C1 AIM identifier for EAN 128 is automatically added by default in front of EAN 128 bar codes.

Include]C1 Identifier (*)



Remove]C1 Identifier

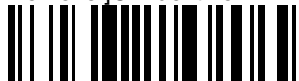

CIP 128 French pharmaceutical codes

embedded CIP 39 data, fixed length 14 characters, Code 128 character set C

Not Active (*)



Active



6. Set up the symbology parameters

Code 128 / EAN 128

Additional parameters—*ScanPlus Reference Manual*

- FNC1 separator character—EAN-128 norms
 - GS function character (ASCII 29) (*)
 - user-defined
- barcode length (number of characters)
 - any length (*)
 - minimum length = 6
 - minimum length—user-defined

6. Set up the symbology parameters

Interleaved 2 of 5

Activation



Barcode length

The minimum length possible for Interleaved 2 of 5 is 2 characters:

[barcode data + check digit if applicable]

Interleaved 2 of 5 always encodes an even number of characters. To handle codes with an odd number of characters, the ScanPlus will accept a code with the last character printed as 5 narrow bars. In this case, all useful characters are transmitted.

For maximum security, we strongly recommend that you use one of the following parameters with all ScanPlus products:

- **Compose 1 or 2 Fixed Lengths (the safest configuration),**
- **Compose Minimum Length.**

Compose 1 or 2 Fixed Lengths provides the best security if the codes in your application have fixed lengths.

Compose Minimum Length is recommended if the codes in your application do not have fixed lengths.

Use the special number codes provided on the back cover of this Installation Guide and scan End Selection once or twice as required.

6. Set up the symbology parameters

Interleaved 2 of 5

Barcode length

Compose 1 or 2 Fixed Lengths



1 fixed length: Compose 1 or 2 Fixed Lengths
<length>—End Selection—End Selection

2 fixed lengths: Compose 1 or 2 Fixed Lengths
<first length>—End Selection
<second length>—End Selection—End Selection

Compose Minimum Length (default = 6)



minimum length: Compose Minimum Length
<length>—End Selection

Additional parameters—*ScanPlus Reference Manual*

- check digit - not used (*)
- check digit mod 10 - checked and transmitted
- checked but not transmitted
- French CIP HR check digit - checked and transmitted
- checked but not transmitted
- barcode length (number of characters) - minimum length = 6 (*)
- any length

6. Set up the symbology parameters

Matrix 2 of 5

Activation



Barcode length

The minimum length possible for Matrix 2 of 5 is 3 characters:

[barcode data]

For maximum security, we recommend that you use the Compose Minimum Length parameter with all ScanPlus products.

Use the special number codes provided on the back cover of this Installation Guide and scan End Selection.

Compose Minimum Length (default = 6)



minimum length: Compose Minimum Length
<length>—End Selection

Additional parameters—*ScanPlus Reference Manual*

- barcode length (number of characters) - minimum length = 6 (*)
- any length

6. Set up the symbology parameters

MSI Code

Activation



Check Digit

Check Digit Mod 10—Checked And Transmitted (*)



Check Digit Mod 10—Checked But Not Transmitted



Check Digit Double Mod 10—Checked And Transmitted



Check Digit Double Mod 10—Checked But Not Transmitted



Additional parameters—*ScanPlus Reference Manual*

- barcode length (number of characters)
- minimum length = 6 (*)
 - any length
 - minimum length—user-defined

6. Set up the symbology parameters

PDF417

Activation

PDF417 is only available with the ScanPlus PDF.

Not Active



Active (*)



6. Set up the symbology parameters

Plessey Code

Activation



Check digit



Additional parameters—*ScanPlus Reference Manual*

- barcode length (number of characters) - any length (*)
- minimum length = 6
- minimum length—user-defined

6. Set up the symbology parameters

Standard 2 of 5

Standard 2 of 5 is also referred to as "Straight 2 of 5" and "Industrial 2 of 5".

Activation



Barcode length

The minimum length possible for Standard 2 of 5 is 3 characters:

[barcode data + check digit if applicable]

For maximum security, we strongly recommend that you use one of the following parameters with all ScanPlus products:

- **Compose 1 or 2 Fixed Lengths (the safest configuration),**
- **Compose Minimum Length.**

Compose 1 or 2 Fixed Lengths provides the best security if the codes in your application have fixed lengths.

Compose Minimum Length is recommended if the codes in your application do not have fixed lengths.

Use the special number codes provided on the back cover of this Installation Guide and scan End Selection once or twice as required.

6. Set up the symbology parameters

Standard 2 of 5

Barcode length

Compose 1 or 2 Fixed Lengths



1 fixed length: Compose 1 or 2 Fixed Lengths
<length>—End Selection—End Selection

2 fixed lengths: Compose 1 or 2 Fixed Lengths
<first length>—End Selection
<second length>—End Selection—End Selection

Compose Minimum Length (default = 6)



minimum length: Compose Minimum Length
<length>—End Selection

Additional parameters—*ScanPlus Reference Manual*

- start/stop bars - Identicon (6 bars) (*)
 - Computer Identics (4 bars)
- check digit mod 10 - not used (*)
 - checked and transmitted
 - checked but not transmitted
- barcode length (number of characters) - minimum length = 6 (*)
 - any length

6. Set up the symbology parameters

UPC/EAN code families (UPC-A, UPC-E, EAN-8, EAN-13)

Activation

Active—UPC/EAN (*) (ScanPlus SP / ER / XP)



Not Active—UPC/EAN (*) (ScanPlus PDF)



UPC-A Transmitted as EAN-13 (*)



UPC-A Transmitted as UPC-A



Add-On Digits—Not Required But Transmitted If Read (*)



Add-On Digits—Required And Transmitted



Add-On 2—Not Active (*)



Add-On 2—Active



Add-On 5—Not Active (*)



Add-On 5—Active



6. Set up the symbology parameters

UPC/EAN code families (UPC-A, UPC-E, EAN-8, EAN-13)

Check digit

UPC/EAN code format: *<leading character>* *<number system>* *<data>* *<check digit>*

UPC-A Check Digit—Transmitted (*)



UPC-A Check Digit—Not Transmitted



UPC-E Check Digit—Transmitted (*)



UPC-E Check Digit—Not Transmitted



EAN-8 Check Digit—Transmitted (*)



EAN-8 Check Digit—Not Transmitted



EAN-13 Check Digit—Transmitted (*)



EAN-13 Check Digit—Not Transmitted



6. Set up the symbology parameters

UPC/EAN code families (UPC-A, UPC-E, EAN-8, EAN-13)

Transmission of number system

UPC/EAN code format: <leading character> <number system> <data> <check digit>

A regular UPC-A has a transmitted number system equal to 0. To transmit the additional leading character (country code), select the parameter UPC-A Transmitted As EAN-13.

UPC-A Number System—Transmitted (*)



UPC-A Number System—Not Transmitted



UPC-E Number System—Transmitted (*)



UPC-E Number System—Not Transmitted



Additional parameters—*ScanPlus Reference Manual*

- UPC/EAN format selection
 - reactivate all—UPC-A, UPC-E, EAN-8, EAN-13 (*)
 - UPC-A deactivated
 - UPC-E deactivated
 - EAN-8 deactivated
 - EAN-13 deactivated
- re-encoding UPC-E, EAN-8
 - UPC-E transmitted as UPC-E (*)
 - UPC-E transmitted as UPC-A
 - EAN-8 transmitted as EAN 8 (*)
 - EAN-8 transmitted as EAN-13

6. Set up the symbology parameters

7

Set up the operating parameters— Activate the pushbutton

*operating
parameters*

parameters that affect the way the different ScanPlus models operate—general operating parameters include pushbutton activation, beep and indicator LED settings, operating mode settings, etc.

ScanPlus operating parameters

Now that you have entered your interface number and set up your data transmission and symbology parameters (if required), you are ready to use your ScanPlus in most working situations.

If you have a pushbutton model, you may still have to activate the pushbutton—the pushbutton is deactivated by default. Use your ScanPlus to read the appropriate pushbutton activation code provided on the following pages.

At the end of this section you will find a full list of additional ScanPlus operating settings.

The full set of ScanPlus operating parameter options is provided in the *ScanPlus Reference Manual*.

Resetting the default ScanPlus operating settings

If you want to reset all the default ScanPlus operating settings, you can scan the Reset Factory Defaults bar code provided in Appendix C, but you will then have to completely reconfigure your ScanPlus.

In most cases, it is easier to reselect the individual settings as required.

7. Set up the operating parameters—Activate the pushbutton

Pushbutton models

By default, the pushbutton on ScanPlus pushbutton models is deactivated.

To activate the pushbutton, you must select the appropriate pushbutton activation code for your ScanPlus model (standard or energy saver).

The ScanPlus does not flash in standby when the pushbutton is activated.

Standard pushbutton models

Standard pushbutton models are suitable for standard applications where energy consumption is not a critical parameter.

When the ScanPlus goes into standby after one of the time-out conditions has been satisfied, the reading light and read function are switched off. Full energy is restored when the next reading situation occurs.

ScanPlus ER/XP/PDF standard pushbutton models can be configured to produce an aiming beam when in standby mode. The aiming beam is a red light used to position the ScanPlus correctly over the bar codes before reading is activated.

Energy saver pushbutton models

Energy saver pushbutton models are specially designed for energy-critical applications—using the ScanPlus with laptop computers for example.

When the ScanPlus goes into standby after one of the time-out conditions has been satisfied, current consumption drops to zero until the next reading situation occurs.

Activating energy saver pushbutton models deactivates the power-up beeps and power-up LED—they can not be activated in Energy Saver mode.

7. Set up the operating parameters—Activate the pushbutton

Pushbutton models

Pushbutton deactivation

By default, the pushbutton on ScanPlus pushbutton models is deactivated.



Pushbutton activation

Pushbutton operating scenario

Other pushbutton operating scenarios are provided in the *ScanPlus Reference Manual*.

The same operating scenario is provided for all pushbutton models—when the pushbutton is pressed, the ScanPlus remains active for a default period of 2 s and goes into standby before the end of this period if there is a good read.

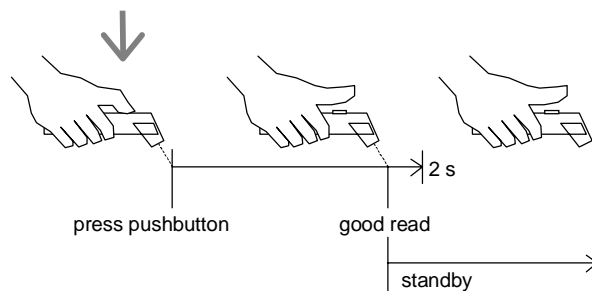

Active For Read Duration (2 s)—Standby After Good Read

7. Set up the operating parameters—Activate the pushbutton

Pushbutton models

Activation—Standard pushbutton models

Only supported by ScanPlus models with part numbers 0-xxxxxx-2x-xx.

 **Do not use this code with ScanPlus models that do not have a pushbutton.**

Standard Pushbutton
Active For Read Duration (2 s)—Standby After Good Read



Activation—Standard pushbutton models—Aiming beam

Only supported by ScanPlus ER / XP / PDF models with part numbers 0-xxxxxx-2x-xx.

 **Do not use this code with ScanPlus models that do not have a pushbutton.**

Standard Pushbutton—Aiming Beam
Active For Read Duration (2 s)—Standby After Good Read



Activation—Energy saver pushbutton models

Only supported by ScanPlus models with part numbers 0-xxxxxx-1x-xx.

 **Do not use this code with ScanPlus models that do not have a pushbutton.**

Energy Saver
Active For Read Duration (2 s)—Standby After Good Read



7. Set up the operating parameters—Activate the pushbutton

Pushbutton models

Additional parameters—*ScanPlus Reference Manual*

- standard pushbutton models
 - active for read duration (2 s)
 - repeat read duration after good read
 - active while pushbutton pressed
 - standby after good read
- standard pushbutton models—aiming beam
 - active for read duration (2 s)
 - repeat read duration after good read
 - active while pushbutton pressed
 - standby after good read
- energy saver pushbutton models
 - active for read duration (2 s)
 - repeat read duration after good read
 - active while pushbutton pressed
 - standby after good read
- pushbutton read duration
 - user-defined (default 2 s, maximum = 65 s)

7. Set up the operating parameters—Activate the pushbutton

Additional operating parameters—*ScanPlus Reference Manual*

**Additional operating parameters not provided in this Installation Guide.
Factory default settings are indicated by an asterisk (*).**

Configuration modes

- configuration authorization modes - enable (*)
 - configuration inhibit after 1 mn
- temporary configuration mode - enable
 - restore current configuration
 - update current configuration
- transparent configuration mode - enable
- display data string mode - enable
- RS-232 slave mode - enable

Flashing mode

- LED economizer flash - flash after 10 minutes (*)
 - no flash
 - user-defined time-out before flash (1 to 60 minutes)

Beeps / green indicator LED

- power-up beeps / power-up LED - on (*)
 - off
- good read beeps - 1beep (*)
 - 2 beeps
 - no beep
- timing of good read beeps - before transmission (*)
 - after transmission
- duration of good read beeps - 80 ms (*)
 - 60 ms
 - 200 ms
 - 300 ms
 - user-defined (0 to 999 ms)
- good read LED - on (*)
 - off

7. Set up the operating parameters—Activate the pushbutton

- 2D crackle / LED flicker - crackle on (*)
- LED flicker on
- crackle off - LED flicker off

Data decoding security parameters

- predefined security levels - normal security level (*)
- medium security level
- high security level
- consecutive same read data validation - single read before transmission (*)
- user-defined number of consecutive same reads before transmission (maximum = 10)
- time-out between identical consecutive codes - 300 ms (*)
- user-defined (maximum = 2550 ms)
- time-out between different consecutive codes - no time-out (*)
- user-defined (maximum time-out = 2550 ms)

Scan rate parameters—ScanPlus SP

- scan rate - 90 scans/s (*)
- 115 scans/s
- 140 scans/s
- 230 scans/s
- scan rate / decode rate ratio - decode rate = scan rate (*)
- decode rate = scan rate / 2

7. Set up the operating parameters—Activate the pushbutton



Pin assignments—Single-output RS-232 CMM

Standard DB-25S "DTE" female (P/N 704300)		Standard DB-25S "DTE" male (P/N 704310)	
1	Frame Ground	1	Frame Ground
2	Transmit Data	2	Transmit Data
3	Receive Data	3	Receive Data
4	Request to Send	4	Request to Send
5	Clear to Send	5	Clear to Send
6	NC	6	NC
7	Signal Ground	7	Signal Ground
8	NC	8	NC
12	+5 Volts	12	+5 Volts
20	NC	20	NC

Standard DB-25S "DCE" female (P/N 704320)		Standard AT 9-pin serial "DCE" female (P/N 704340)	
1	Frame Ground	1	NC
2	Receive Data	2	Transmit Data
3	Transmit Data	3	Receive Data
4	Clear to Send	4	NC
5	Request to Send	5	Signal Ground
6	NC	6	NC
7	Signal Ground	7	Clear to Send
8	NC	8	Request to Send
12	+5 Volts	9	NC
20	NC		

pins 6, 8, and 20 on 25-pin connectors are shorted

A. Pin assignments—Single-output RS-232 CMM

B Jumper settings—Dual-output RS-232 CMM

Changing the jumper settings

1. Remove the four attachment screws and remove the cover of the CMM.
2. Set the jumpers as required (see the available settings on the next page).

Jumper settings are identical for standard and reverse gender dual-output RS-232 CMMs.

Make sure the TO HOST and TO TERMINAL labels are correctly positioned when you reassemble the CMM (see *RS-232—Dual-output CMM and external power supply* in Section 2).

B. Jumper settings—Dual-output RS-232 CMM

Dual-output RS-232 CMM

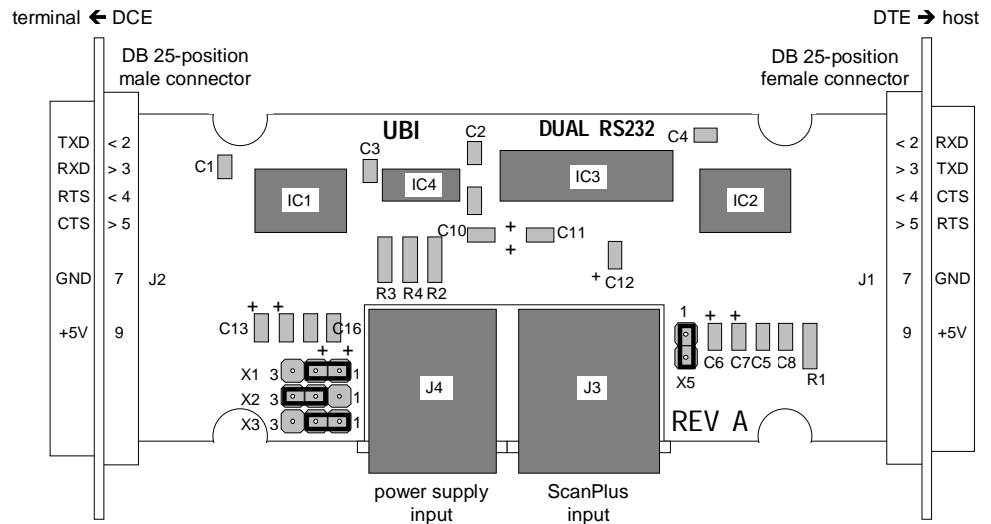

Jumper settings

Data transmission settings

transmit to host only (default)

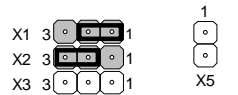

transmit to terminal only

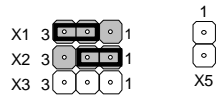

transmit to host and terminal

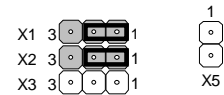

ScanPlus-host RTS/CTS handshaking settings

RTS/CTS handshaking on (default)

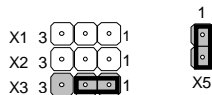

RTS/CTS handshaking off

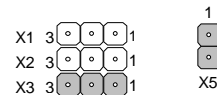

C If you have a problem . . .

This appendix describes things you can try if you have problems with your ScanPlus during power-up, configuration and normal operation.

If you can not solve the problem yourself, please contact your UBI representative.

Before you contact your UBI representative . . .

Look in the following checklists if you have any of the following problems:

- no LEDs,
- no beeps,
- error beeps,
- no transmission,
- incorrect transmission.

Setup problems checklist

- correct ScanPlus model
- correct CMM / cables / external power supply
- ScanPlus connected up correctly
- system switched on—sufficient electrical power
- correct power-up indication—2 beeps
- number of green indicator LED flashes at power-up—correct interface number selected for your ScanPlus model
- End Selection scanned once or twice if required for certain configuration codes

C. If you have a problem . . .

Reading problems checklist

- correct symbologies selected for the codes you are trying to read
- symbologies you read are available for your ScanPlus
- all unnecessary symbologies disabled
- barcode length compatible with minimum length / fixed length parameter settings of ScanPlus
- ScanPlus configured for check digit and no check digit present in code
- barcode quality, damaged or poorly printed codes, "fragile" symbologies—read the appropriate test code to see if there is a problem with the symbology (Appendix D)
- correct operating parameters
- pushbutton activated
- pushbutton pressed
- aiming beam activated if required (standard pushbutton models)

Transmission problems checklist

- interface number selected—if indicator LED stays green after power-up, no interface number has been selected
- correct interface number selected for your host system hardware configuration
- all unnecessary symbologies disabled
- correct data transmission settings for your host system
- inter-character delay value required if transmitted data incomplete or incorrect

C. If you have a problem . . .

Try a general reset of the ScanPlus . . .

If you do not find a solution after checking the above points, you can try a general reset of the ScanPlus.

Reset Factory Defaults resets all the ScanPlus operating parameters to their factory default settings:

- null interface (no host system interface driver selected—no transmission),
- default symbologies and symbology settings,
- default ScanPlus operating settings (pushbutton deactivated, default LED and beep settings, etc.).

 **If you scan Reset Factory Defaults, you will have to re-enter the appropriate interface number for your host system and any custom settings if applicable. It is often easier to reset individual parameters.**

1. Switch off the electrical supply to the ScanPlus:
 1. Switch off the host system or disconnect the ScanPlus.
 2. Disconnect the ScanPlus external power supply if applicable.
2. Position the ScanPlus over the Reset Factory Defaults code.
3. Provide electrical power to the ScanPlus:
 1. Reconnect the ScanPlus external power supply if applicable.
 2. Switch on the host system or reconnect the ScanPlus.

If you have a pushbutton model, press and hold the pushbutton when you perform step 3.



C. If you have a problem . . .

4. Scan the interface number for your system (section 4, *Enter the interface number for your host system*).
5. Customize the data transmission settings for your host system if required (section 5, *Set up the data transmission parameters*).
6. Customize the symbology parameter settings if required (section 6, *Set up the symbology parameters*).
7. If you have a pushbutton model, activate the pushbutton (section 7, *Set up the operating parameters—Activate the pushbutton*).

If you still have a problem . . .

Contact your UBI representative and give full details of the problem.

Your UBI representative may ask you to provide the software / CPU version numbers for your ScanPlus. If the ScanPlus is powered up, try to read the following code to display this information on your host system screen if applicable.



D Test codes

Codabar



123456

Code 39



CODE-39

Code 93

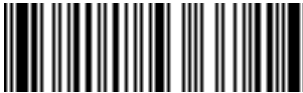

CODE-93

Code 128



CODE-128

EAN 128



]C1EAN 128

Interleaved 2 of 5



12345678901234

Standard 2 of 5

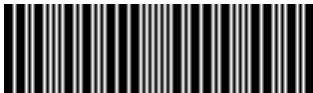

123456

Matrix 2 of 5



012345

D. Test codes

MSI Code



12345666

Plessey Code



80001495050

EAN-8



12345670

EAN-13



1234567890128

UPC-A



0 01234 50000 7

UPC-E



0 012345 7

Codablock F

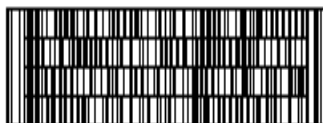

UBI ScanPlus XP and XP PDF
CCD Bar Code Scanners

PDF417



UBI ScanPlus XP and XP PDF
CCD Bar Code Scanners

UBI Inc.
Ammendale Technology Park
12240 Indian Creek Court
Beltsville
MD 20705
USA
Tel: +1 301 210 3000
Fax: +1 301 210 5498

UBI Ltd
Attenborough House
15 Bennet Road
Reading
Berkshire RG20QX
ENGLAND
Tel: +44 118 9876594
Fax: +44 118 9876305

UBI International / UBI France SA
Immeuble "Le Newton"
23 avenue de l'Europe
78402 Chatou Cedex
FRANCE
Tel: +33 (0)1.30.15.25.35
Fax: +33 (0)1.34.80.14.33

UBI SrL
Via Speranza 35
40068 San Lazzaro di Savena
Bologna
ITALY
Tel: +39 51 453270
Fax: +39 51 450460

UBI GmbH
Max-Planck-Strasse 9-13
D-85716 Unterschleissheim/München
GERMANY
Tel: +49 89 32 18 10 0
Fax: +49 89 32 18 10 20

UBI Nordic AB
Bredgatan 10
222 21 Lund
SWEDEN
Tel: +46 46 350 660
Fax: +46 46 350 661

UBI Danmark AS
Hovedvejen 122
2600 Glostrup
DENMARK
Tel: +45 43 43 90 72
Fax: +45 43 63 90 72

UBI Norge A/S
Postboks 33
1483 Skytta
NORWAY
Tel: +47 67 06 03 20
Fax: +47 67 06 05 01

UBI OY
Valkjärventie 1
02130 Espoo
FINLAND
Tel: +358 90 52 37 21
Fax: +358 90 52 92 24

UBI Russia
Kamennoostrovskii Prospect 29-2
St Petersburg 197 022
RUSSIA
Tel: +7 812 232 81 39
Fax: +7 812 119 13 82

UBI representative:

SP/XX/IG/12/E/980228

Number codes

