

Operator's Guide

P/N 3-740049-00



Sabre 1555 RFID & Bar Code Reader

Guía del Usuario

Guida dell'operatore

Guide de l'Opérateur

Guia do Utilizador

Bedieneranleitung



Intermec
Technologies Corporation

A UNOVA Company

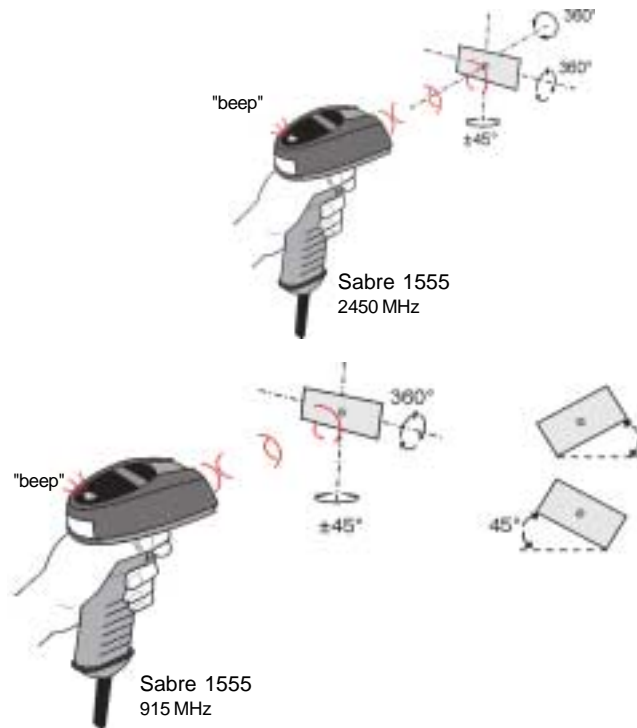
RFID reader operation

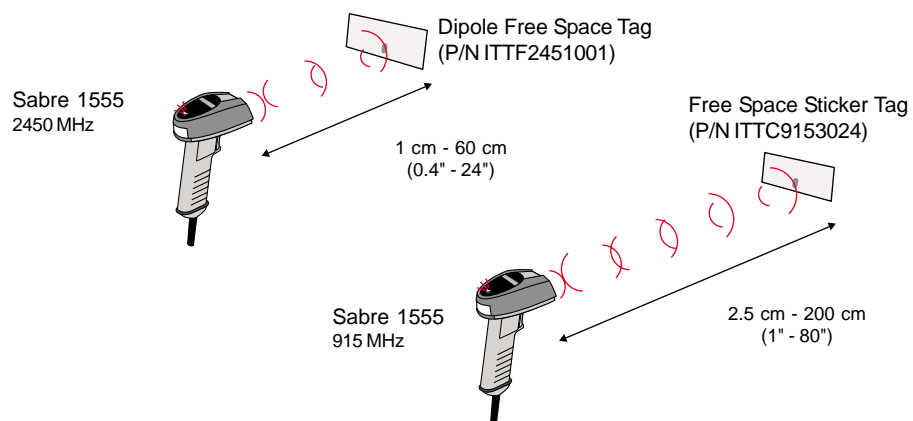

RFID reader reading distance using free space tag



RFID tag read range examples (2450 MHz and 915 MHz)

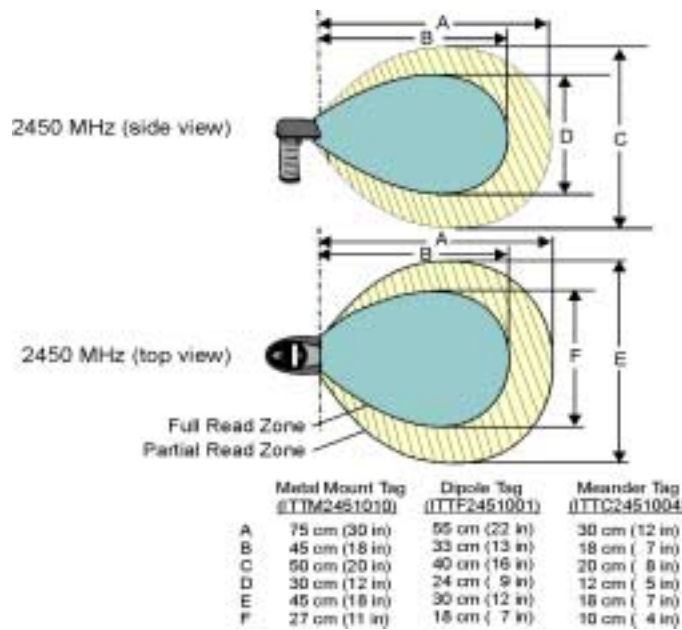

For 2450- and 915- MHz Products

The partial read zone is most affected by environmental conditions (such as obstructions, metal structures), equipment factors (type of tag, number of tags), and variation from unit to unit.

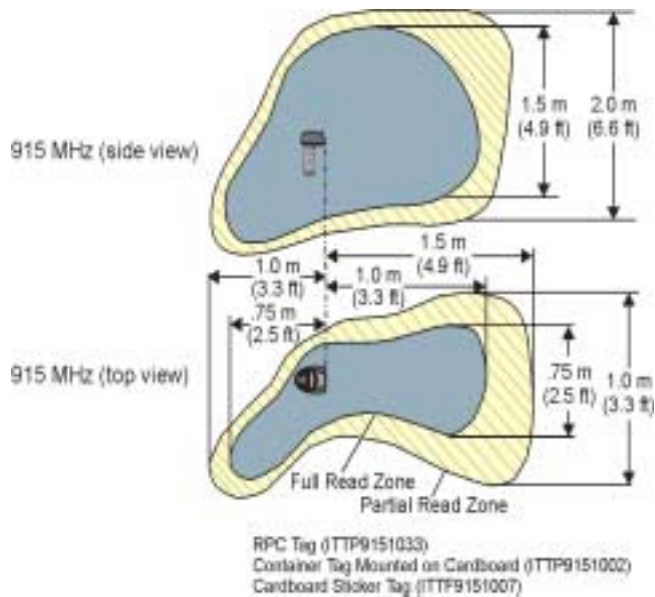

In the 915-MHz example (top view), the user held the 1555 unit in the right hand. The user's body shielded the RF and created the shallow read zones to the left and behind of the 1555 unit. For lefthand users, the read zones will be reversed.

Bar code reader operation

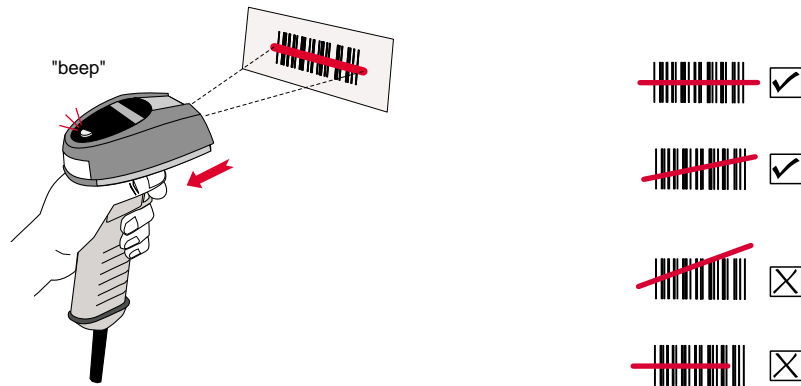

Bar code reader reading distance

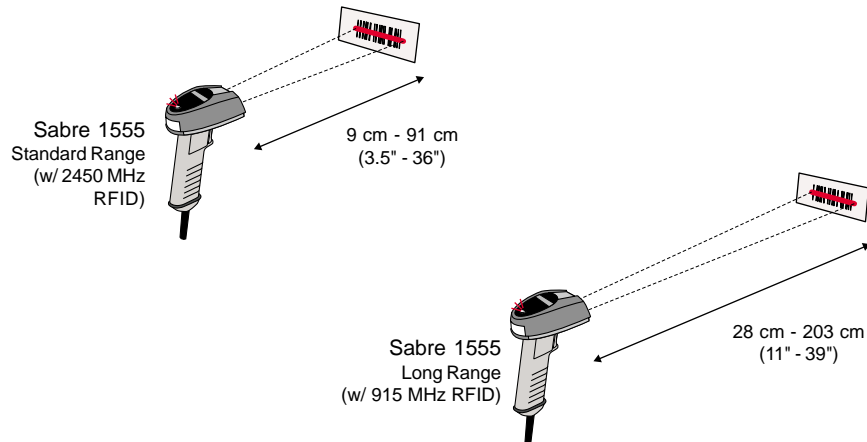

Laser warnings

The Sabre 1555 has a maximum laser output of 1mW at 630-680 nm and complies with the following safety standards:

USA: CDRH - Class II Laser Product (CFR 21 Subpart J)
IEC 825-1 EN 60825-1 - Class 2 Laser Product

Fix these warning labels onto the product if they are not already present.

Collez les étiquettes d'avertissement sur votre produit. Cole as etiquetas de precaução no equipamento.

Bringen Sie Warnetiketten auf dem Produkt an. Un'etichetta di avviso per il laser è da applicare sul prodotto.

Fije la etiqueta de advertencia en el producto.

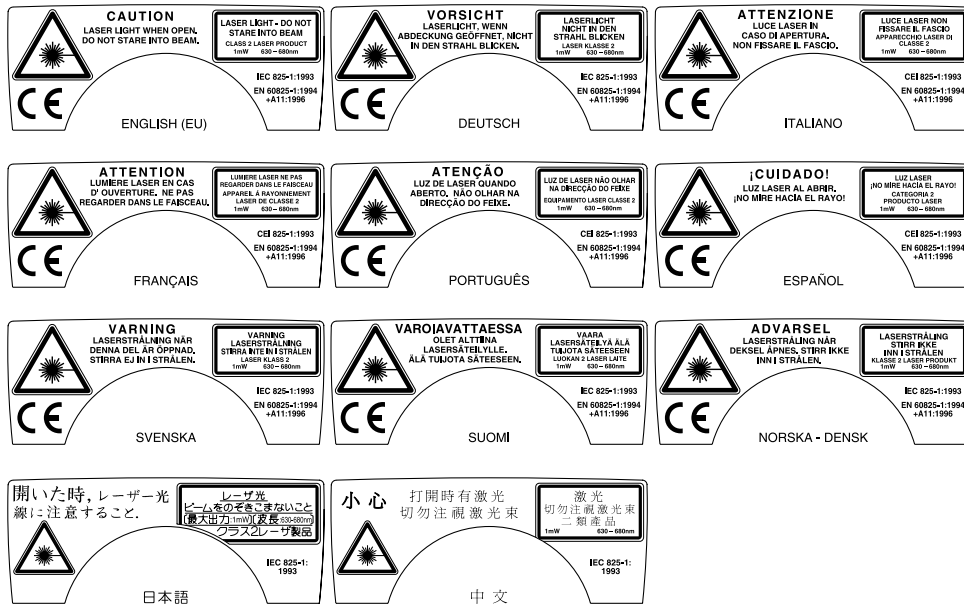
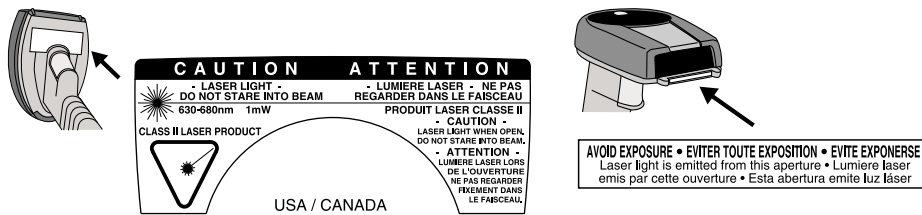

CAUTION – Use of controls or adjustments or performance of procedures other than those specified herein may result in hazardous radiation exposure.

VORSICHT – Bei einer anders als hier beschriebenen Verwendung der Bedienelemente oder Veränderungen oder einer anderen Ausführung der Arbeitsabläufe kann es zu gefährlichen Strahlungen kommen.

ATTENTION – L'utilisation de contrôles/commandes ou de réglages ou l'exécution de procédures autres que ceux précisés dans le présent document peuvent provoquer une exposition dangereuse aux radiations.



Regulatory statements

USA & Canada: This Class B digital apparatus meets all requirements of the Canadian Interference-Causing Equipment Regulations. This device requires a radio license, unless it is used totally inside a building. (The user must obtain this license.)

Cet appareil numérique de la classe B respecte toutes les exigences du Règlement sur le matériel brouilleur du Canada. Cet appareil exige une licence radio à moins d'être entièrement installé dans un bâtiment. (L'utilisateur doit obtenir cette licence.)

To prevent radio interference to the licensed service, this device is intended to be operated **indoors only** and should be kept away from windows to provide maximum shielding.

This device complies with Part 15 of the FCC Rules and with RSS-210 of Industry Canada. Operation is subject to the following two conditions: (1) this device may not cause harmful interference, and (2) this device must accept any interference received, including interference that may cause undesired operation.

This equipment is intended for operation in a commercial environment, in compliance with the requirements for a Class A digital device, pursuant to part 15 of the FCC Rules and it must not be used in a residential environment; however, it has also been tested and found to comply with the more stringent requirements for a class B device, pursuant to Part 15 of the FCC rules. It generates, uses, and can radiate radio frequency energy. If not installed and used in accordance with the instructions, it may cause interference to radio communications. If this equipment causes interference, the user will be required to correct the interference at the user's own expense.

To maintain compliance with the FCC Rules, the I/O cables that interconnect between the device and any peripheral (such as a reader) must be as specified by Intermec.

This product complies with the American National Standards Institute NCIT 256-1999 standard for RFID Item Management.

Operator Warning: FCC regulations limit exposure to radio frequency (RF) radiation. To comply with these regulations, the operator of this device must maintain a distance of at least 5 cm (2 inches) from the front part of the device to any bystanders under normal operating conditions. **While the device is on, the operator's body and parts of the body, such as eyes, hands, or head, must be 5 cm (2 inches) or farther from the front of the device.**



This device is UL listed (UL 1950/C22.2 No. 950) for safety when powered by a host system or by one of the following external Intermec power supplies: Catalog No. and P/N 070826, 90-264 VAC, 47-63 Hz. This device is CSA certified.

Intermec hereby declares that the Sabre 1555 has been tested and found compliant with the below listed standards as required by the EMC Directive 89/336/EEC as amended by 92/31/EEC and by the Low Voltage Directive 73/23/EEC as amended by 93/68/EEC: EN55022, EN50082-2, EN60950

This device is TÜV GS licensed (EN 60950 and EN 60825-1) for safety when powered by a host system or by the following external Intermec power supply: Catalog No. and P/N 070826, 90-264 VAC, 47-63 Hz. The device is CSA certified.

Australia-New Zealand: This equipment has been tested and found to conform to the Australian EMC framework concerning Class B digital devices, prescribed by the Australian and New-Zealand standard AS/NZS 3548.  N309

Mexico: Este equipo cumple con la certificación NOM.

The information contained in this document is for informational purposes only and is subject to change without notice. No part of this document may be copied or reproduced in any manner without the prior written permission of Intermec Technologies Corporation.

Sabre products are covered by patents issued or pending in the USA and other countries.

The word Intermec, the Intermec logo, Sabre and EasySet are either trademarks or registered trademarks of Intermec.

Throughout this document, trademarked names may be used. Rather than put a trademark (™ or ®) symbol in every occurrence of a trademarked name, we state that we are using the names only in an editorial fashion, and to the benefit of the trademark owner, with no intention of infringement.



To comply with RF exposure limits, bystanders should stay away from the front of this product, at least 5 cm (2 in) for the 2450 MHz version and 4 cm (1.5 in) for the 915 MHz version, when it is in operation. This product complies with all other RF exposure requirements while the unit is in operations, including specific absorption rate (SAR) limits for the user's hand.



Changes or modifications not expressly approved by Intermec could void the user's authority to operate this equipment.



North America / Asia Pacific / Latin America • 6001 36th Avenue West, PO Box 4280, Everett, WA 98203-9280
Tel: +1 425 348 2600 • Fax: +1 425 348 2833 • U.S. service and technical support, tel: 1.800.755.5505 • Canadian
service and technical support, tel: 1.800.688.7043

Europe / Middle East / Africa • Sovereign House, Vastern Road, Reading RG1 8BT, England
Tel: +44 (0) 118 987 9400 • Fax: +44 (0) 118 987 9401

Internet: <http://www.intermec.com>

E-mail: info@intermec.com

Technical information: <http://datacapture.intermec.com>





A **UNOVA** Company

