

Installation Guide

P/N 0-440049-01



MaxiScan 2200 Fixed-position Scanner

Intermec

A **UNOVA** Company

Regulatory Statements



Intermec hereby declares that the MaxiScan 2200 has been tested and found compliant with the below listed standards as required by the EMC Directive 89/336/EEC as amended by 92/31/EEC and by the Low Voltage Directive 73/23/EEC as amended by 93/68/EEC:

EN55022 (1992) EN50082-1 (1998) EN60950 (1993)

USA: This device complies with Part 15 of the FCC Rules. Operation is subject to the following two conditions: (1) this device may not cause harmful interference, and (2) this device must accept any interference received, including interference that may cause undesired operation.

This equipment has been tested and found to comply with the limits for a Class B digital device, pursuant to part 15 of the FCC Rules. It generates, uses and can radiate radio frequency energy. If not installed and used in accordance with the instructions, it may cause interference to radio communications. If this equipment causes interference, the user will be required to correct the interference at the user's own expense.

This equipment complies with the UL 1950 standard.

Canada: This Class B digital apparatus meets all requirements of the Canadian Interference-Causing Equipment Regulations. Cet appareil numérique de la classe B respecte toutes les exigences du Règlement sur le matériel brouilleur du Canada.

This equipment complies with the UL 1950 standard.
Cet équipement est conforme à la norme UL 1950.

Australia-New Zealand: This equipment has been tested and found to conform to the Australian EMC framework concerning Class B digital devices, prescribed by the Australian and New-Zealander standard AS/NZS 3548.



N309

Mexico: Este equipo cumple con la certificación NOM.
This equipment complies with the NOM certification.

The information contained in this document is for informational purposes only and is subject to change without notice. No part of this document may be copied or reproduced in any manner without the prior written permission of Intermec Technologies Corporation.

MaxiScan products are covered by patents issued or pending in the USA and other countries.

© Intermec Technologies Corporation All Rights Reserved

The word Intermec, the Intermec logo, MaxiScan and EasySet are either trademarks or registered trademarks of Intermec.

Throughout this document, trademarked names may be used. Rather than put a trademark (™ or ®) symbol in every occurrence of a trademarked name, we state that we are using the names only in an editorial fashion, and to the benefit of the trademark owner, with no intention of infringement.

North America / Asia Pacific / Latin America

6001 36th Avenue West
PO Box 4280
Everett WA 98203-9280
Tel : +1 425 348 2600
Fax : +1 425 348 2833
U.S. service and technical support, tel: 1.800.755.5505
Canadian service and technical support, tel: 1.800.688.7043

Europe / Middle East / Africa
Sovereign House
Vastern Road
Reading RG1 8BT
England
Tel : +44 118 987 9420
Fax : +44 118 987 9416

Internet :

<http://www.intermec.com>

E-mail :

info@intermec.com

Support :

<http://datacapture.intermec.com>

Laser warnings

English	USA DHHS Standard 21CFR 1040.10 and 1040.11: Class IIa Laser Product IEC 825-1 (1993) EN 60825-1 (1997): Class 1 Laser Product AVOID LONG TERM VIEWING OF DIRECT LASER LIGHT CAUTION - LASER LIGHT WHEN OPEN - DO NOT STARE INTO BEAM
Deutsch	IEC 825-1 (1993) EN 60825-1 (1997): Laser-Produkt der Klasse 1 AUGEN VOR DIREKTEM LASERLICHT SCHÜTZEN VORSICHT! LASERLICHT BEI GEÖFFNETEM GEHÄUSE - NICHT IN DEN STRAHL STARREN
Español	IEC 825-1 (1993) EN 60825-1 (1997): Aparato láser de Clase 1 EVITAR EXPOSICIONES PROLONGADAS DE LA VISTA A LA RADIACION LASER DIRECTA CUIDADO - RADIACION LASER - EN FUNCIONAMIENTO NO MIRAR DENTRO DEL RAYO LASER
Français	IEC 825-1 (1993) EN 60825-1 (1997): Appareil Laser de Classe 1 EVITER TOUTE EXPOSITION PROLONGÉE DE LA VUE AU RAYONNEMENT LASER DIRECT ATTENTION - RAYONNEMENT LASER - EN CAS D'OUVERTURE NE PAS REGARDER DANS LE FAISCEAU
Italiano	IEC 825-1 (1993) EN 60825-1 (1997): Apparecchio Laser Classe 1 NON ESPORRE A LUNGO LA VISTA AD UN IRRADIAMENTO LASER DIRETTO ATTENZIONE - IRRADIAMENTO LASER - AD APPARECCHIO IN FUNZIONE, NON GUARDARE IL FASCIO LUMINOSO
Português	IEC 825-1 (1993) EN 60825-1 (1997): Equipamento Laser Classe 1 LUZ DE LASER - NÃO OLHAR NA DIRECÇÃO DO FEIXE ATENÇÃO - LUZ DE LASER QUANDO ABERTO - NÃO OLHAR NA DIRECÇÃO DO FEIXE
Svenska	IEC 825: Klass I laserprodukt SKYDDA ÖGONEN MOT DIREKT LASERLJUS VARNING - LASERLJUS VID ÖPPNING - STIRRA INTE MOT STRÅLEN

CAUTION – Use of controls or adjustments or performance of procedures other than those specified herein result in hazardous laser light.

VORSICHT – Bei einer anders als hier beschriebenen Verwendung der Bedienelemente oder Veränderungen oder einer anderen Ausführung der Arbeitsabläufe entsteht gefährliches Laserlicht.

CAUTION – L'utilisation de contrôles/commandes ou de réglages ou l'exécution de procédures autres que ceux précisés par le présent document provoquent une lumière laser dangereuse.

What you are going to do . . .

This Installation Guide tells you how to install and set up your MaxiScan 2200 to operate successfully in most working situations.

The present guide does not cover all the configuration capabilities of your MaxiScan 2200. Refer to the appendix for the complete list of configuration options provided with:

- the EasySet System scanner setup software—provided on the "Intermec products cd-rom" and on the <http://datacapture.intermec.com> web site,
- the *MaxiScan 2200 Reference Manual*—available on request.

Step by step how to install and set up your MaxiScan 2200

1	Check you have everything you need.....	7
2	Install the MaxiScan 2200 in its operating location.....	9
3	Switch off the host system and connect up your MaxiScan 2200.....	11
4	Switch on the host system	19
5	Using your MaxiScan 2200.....	21
6	Enter the interface number for your system	23
7	Set up the data transmission parameters	31
8	Set up the symbology parameters.....	41
9	Set up the operating parameters.....	73

Additional information is provided in the Appendix

A	Installing the optional adjustable stand.....	81
B	Installing the MaxiScan 2200 in a fixed reading position	83
C	Changing the cable connector position.....	85
D	Care and replacement of the red reading window.....	89
E	Data transmission parameters	91
F	Symbology parameters.....	95

G	MaxiScan 2200 operating parameters.....	99
H	If you have a problem . . .	103
I	Test codes	105
J	Number codes	111

1 Check you have everything you need

Checklist of items for your installation

- all systems
- the right MaxiScan 2200 model for your host system
 - the right cable for your host system
 - this *MaxiScan 2200 Installation Guide*
 - MaxiScan 2200 user's leaflet if applicable
 - mounting plate
 - replacement red reading window
- options
- external power supply
 - adjustable stand
 - MaxiScan 2200 Reference Manual*

<i>external power supply</i>	6V mains power supply adapter—necessary if the host system does not provide enough electrical power to drive the MaxiScan 2200
------------------------------	--

2 Install the MaxiScan 2200 in its operating location

How do you want to use your MaxiScan 2200?

Normal use



The MaxiScan 2200 is a self-standing scanner for “hands-free” barcode scanning—you just have to pass items in front of the red reading window to read the bar codes.



For items that are too large or not easy to move, you can pick up the MaxiScan 2200 and use it as a hand scanner.

Optional adjustable stand



If you want to read items at a fixed reading angle—up or down, left or right—you may want to use the optional adjustable stand.

Appendix A tells you how to install the optional adjustable stand.

The adjustable stand still allows you to use the MaxiScan 2200 as a hand scanner if required.



Fixed reading position



If you want to install your MaxiScan 2200 in a permanent fixed reading position, you can screw the MaxiScan 2200 directly to the work surface or use the special mounting plate provided in the MaxiScan 2200 product package.

Appendix B tells you how to install the MaxiScan 2200 in a fixed reading position.

If you use the optional adjustable stand or install your MaxiScan 2200 in a permanent fixed reading position, check if you need to change the cable connector position from horizontal to vertical—see Appendix C.

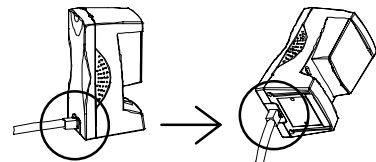

3 Switch off the host system and connect up your MaxiScan 2200

Interfaces

Keyboard wedge	12
RS-232	13
Dual RS-232 C	14
IBM 46xx cash registers.....	15
OCIA cash registers	16
Wand emulation	17

<i>keyboard wedge</i>	MaxiScan 2200 connected between a keyboard and the host system— data from the MaxiScan 2200 is transmitted in keyboard emulation mode to provide instant software compatibility (external power supply necessary)
<i>dual RS-232 C</i>	MaxiScan 2200 connected between two systems communicating through an RS-232 link (external power supply necessary)

Keyboard wedge

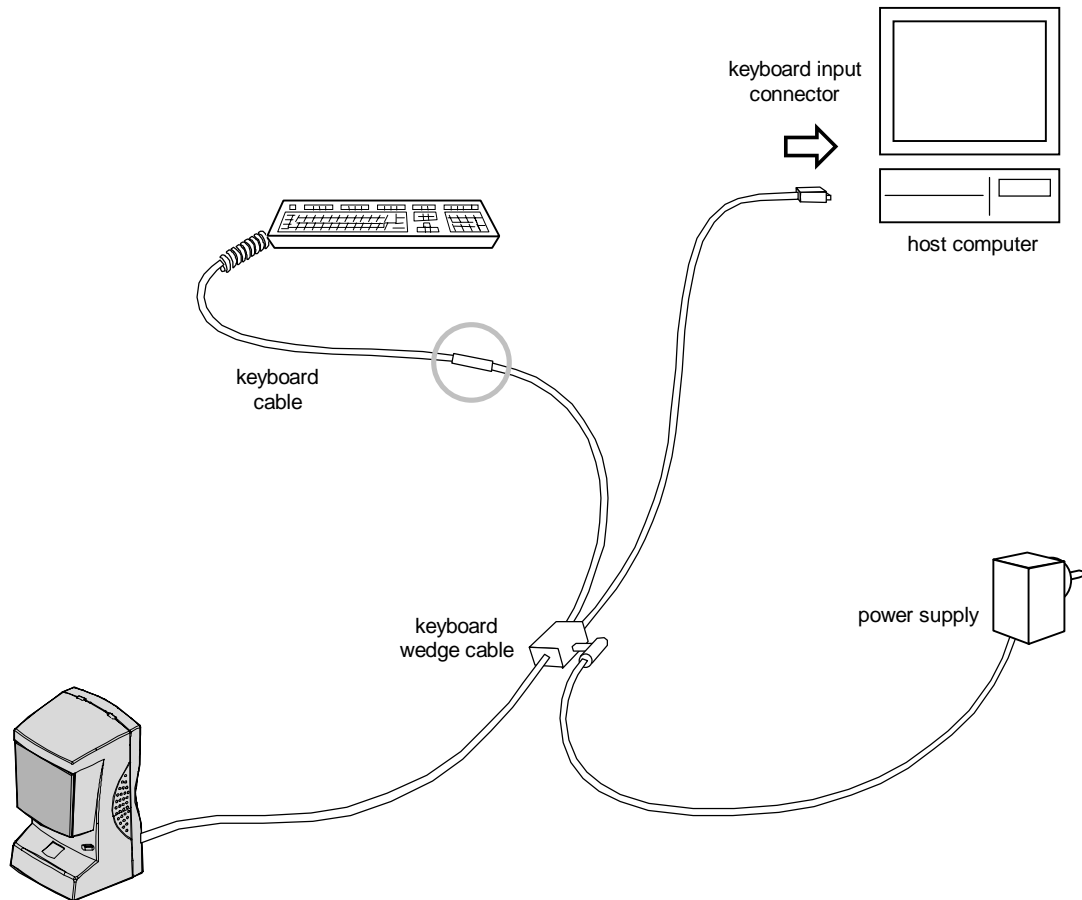

1. Switch off the host system.
2. Disconnect the keyboard from the host computer.
3. Use the keyboard wedge cable to connect the MaxiScan 2200 between the keyboard and the host computer.

Do not switch on the host computer.

4. Connect the power supply to the keyboard wedge cable.
5. Plug the power supply into the mains socket.

RS-232

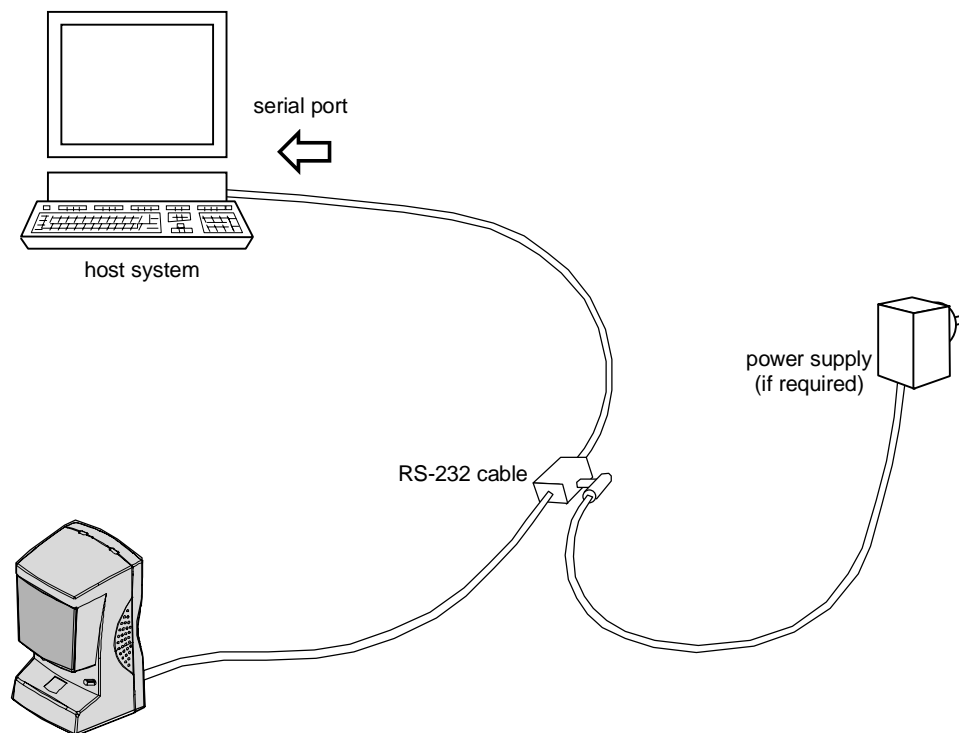

1. Switch off the host system.
2. Use the RS-232 cable to connect the MaxiScan 2200 to the host system.

Do not switch on the host system.

3. If your host system requires an external power supply:
 - Connect the power supply to the RS-232 cable.
 - Plug the power supply into the mains socket.

Dual RS-232 C

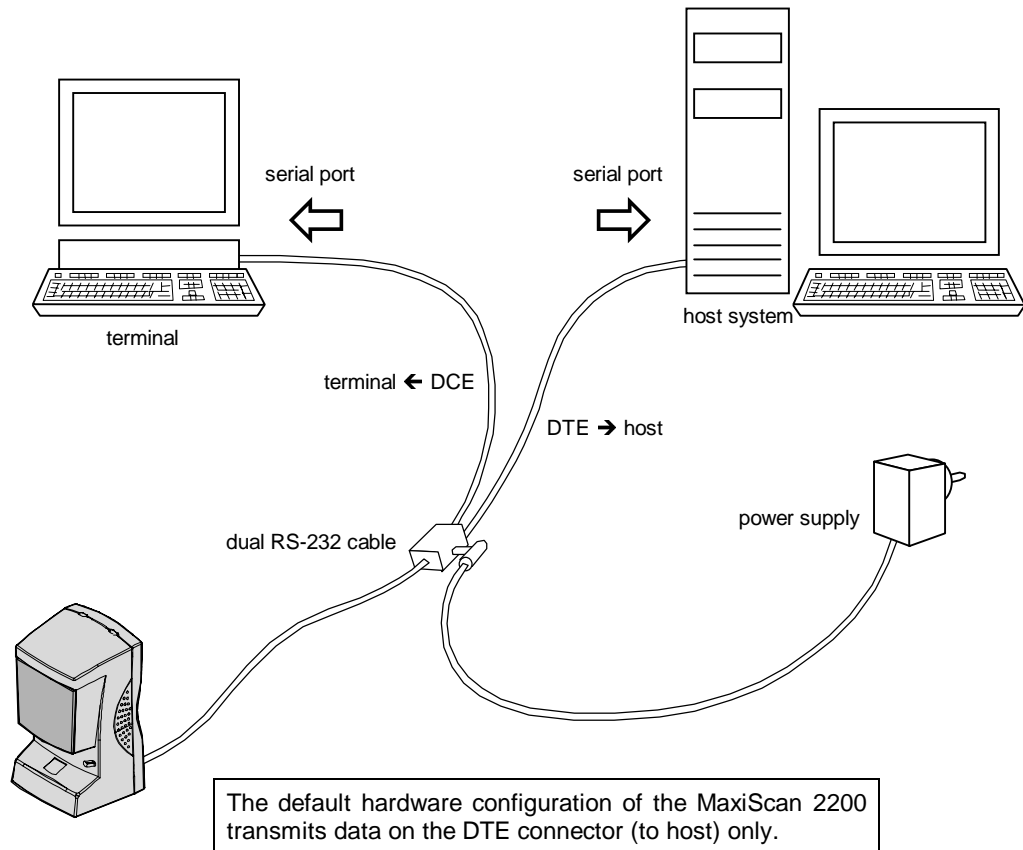

1. Switch off the host system.
2. Disconnect the terminal from the host system.
3. Use the dual RS-232 cable to connect the MaxiScan 2200 between the terminal and the host system.

Do not switch on the host system.

4. Connect the power supply to the dual RS-232 cable.
5. Plug the power supply into the mains socket.

IBM 46xx cash registers

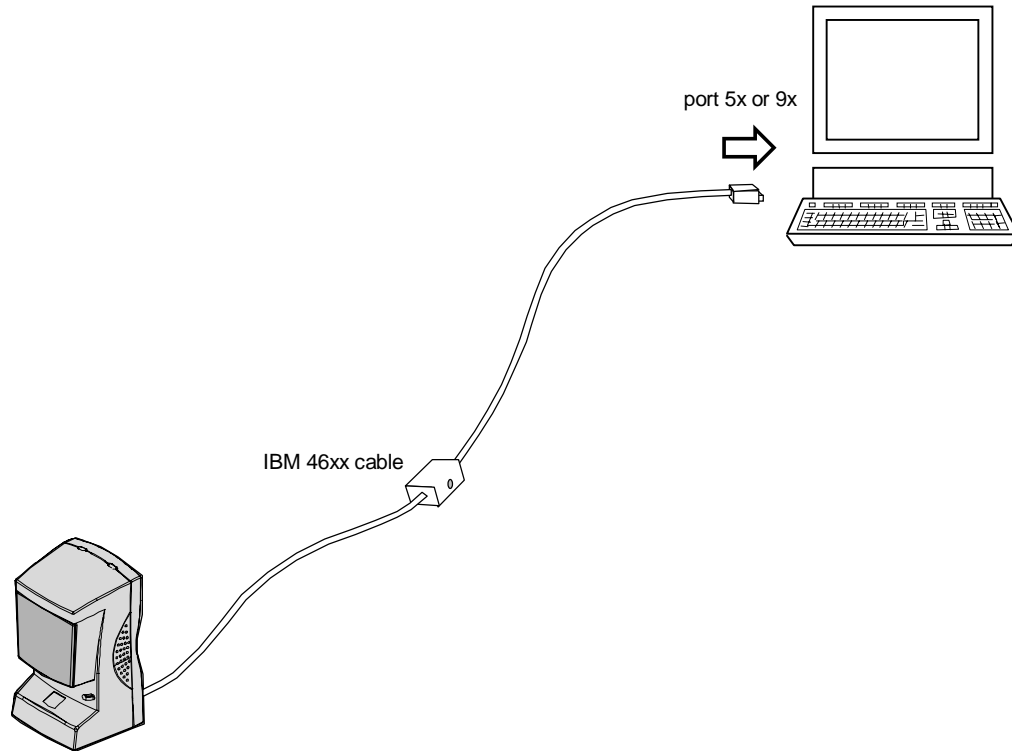

1. Switch off the host system.
2. Use the IBM 46xx cable to connect the MaxiScan 2200 to the host system.

OCIA cash registers

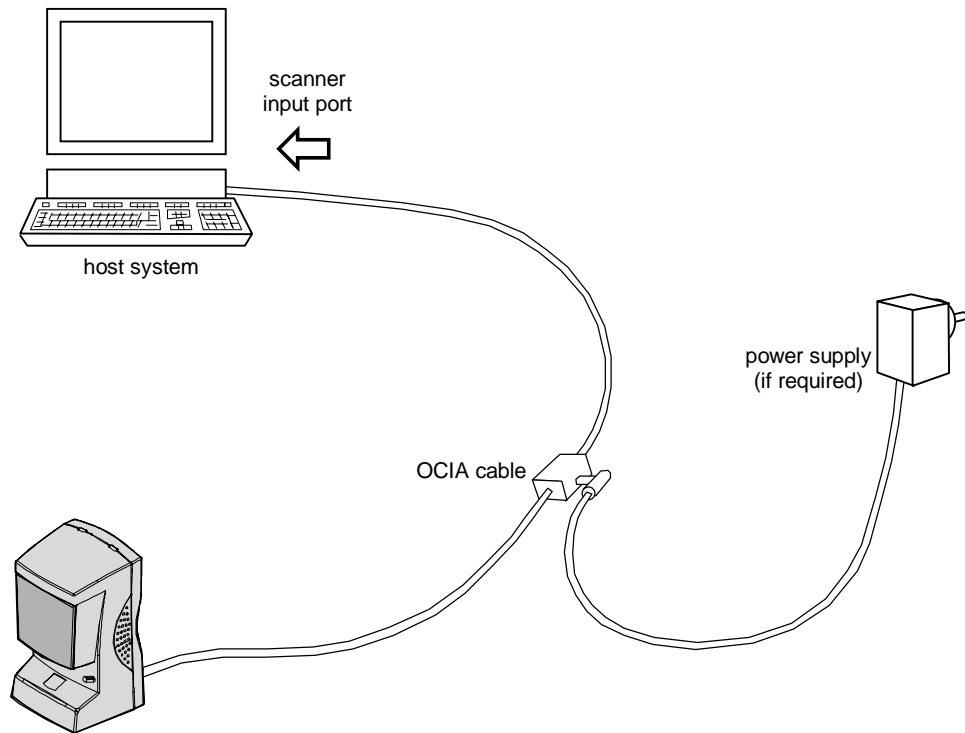

1. Switch off the host system.
2. Use the OCIA cable to connect the MaxiScan 2200 to the host system.

Do not switch on the host system.

3. If your host system requires an external power supply:
 - Connect the power supply to the OCIA cable.
 - Plug the power supply into the mains socket.

Wand emulation

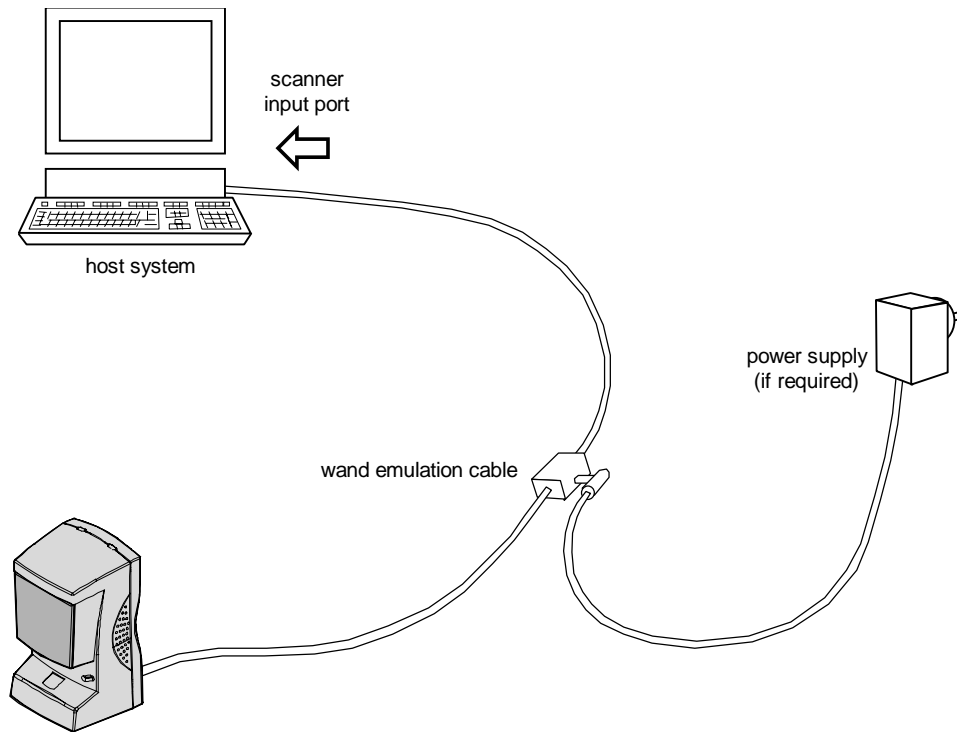

1. Switch off the host system.
2. Use the wand emulation cable to connect the MaxiScan 2200 to the host system.

Do not switch on the host system.

3. If your host system requires an external power supply:
 - Connect the power supply to the wand emulation cable.
 - Plug the power supply into the mains socket.

3 Switch off the host system and connect up your MaxiScan 2200

4 Switch on the host system

What the beeps and LED flashes mean

The red power-up LED of the MaxiScan 2200 will come on.

The indicator LED of the MaxiScan 2200 will flash orange a number of times according to the interface configuration of your model:

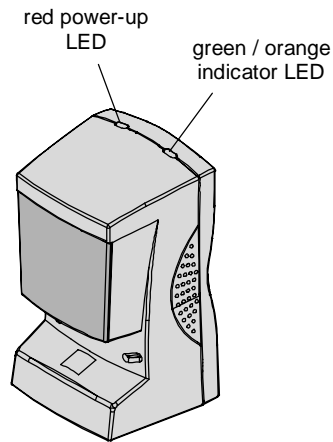

orange LED flashes	interface configuration
2 flashes	RS-232 C dual RS-232 C
3 flashes	IBM 46xx cash registers
4 flashes	RS-232 TTL wand emulation
5 flashes	OCIA cash registers
7 flashes	keyboard wedge

The MaxiScan 2200 will then emit two beeps to indicate that the power-up sequence has been completed.

If the MaxiScan 2200 has already been programmed for a given interface configuration, the indicator LED will stay green.

If no interface has been programmed—which may be the case when you set up for the first time—the indicator LED will stay orange.

5 Using your MaxiScan 2200

Laser safety recommendations

The MaxiScan 2200 will operate in complete safety when used as specified in this Installation Guide.

As for all laser products, avoid staring directly into the laser light beam for long periods of time—prolonged viewing into direct laser light may damage your eyes.

Do not try to dismount the MaxiScan 2200 except as specified in this Installation Guide and always use the scanner only as described in official MaxiScan 2200 documentation.

Reading configuration bar codes

If you have any problems reading the configuration codes, refer to Appendix E for help.

For full details on how to use your MaxiScan 2200, see the user's leaflet for your MaxiScan 2200 model if applicable.

Configuration codes with an asterisk (*) are factory default settings.

What the beeps mean

The MaxiScan 2200 has special beeps for configuration bar codes:

- two beeps indicate that the MaxiScan 2200 has successfully read the configuration code and saved the setting,
- six short beeps indicate a setup error (incorrect configuration code) for the selected interface type.

Reading the codes in this Installation Guide

The configuration codes in this Installation Guide are spaced out to prevent you from reading the wrong code. To make sure that you read the correct code, we recommend that you fold the Installation Guide back to back:

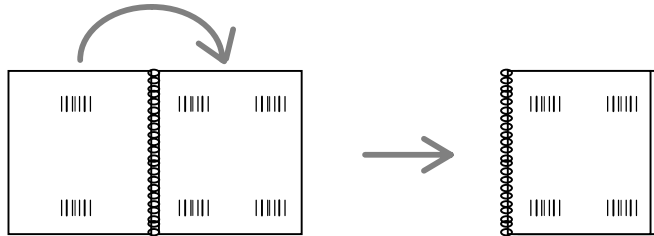

When you present the code to the MaxiScan 2200, make sure that you only present the corner or the side of the page where the code is located. The MaxiScan 2200 can read codes in any direction, so it doesn't matter if you present the code upside-down or sideways:

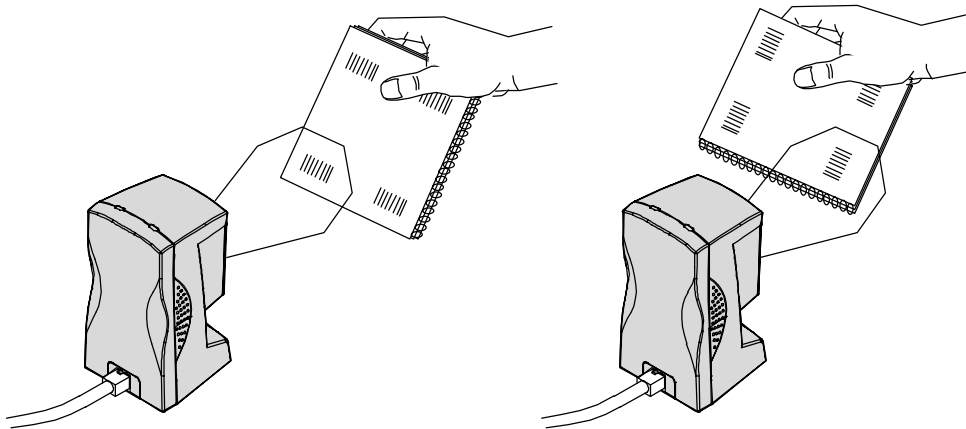

6 Enter the interface number for your system

interface number automatically configures your MaxiScan 2200 by setting interface-specific parameters—in particular data transmission parameters—to suit your operating environment

Which interface number?

1. Look on the next pages to see if there is a predefined interface number for your system hardware configuration.
2. If you find a number for your hardware configuration, use your MaxiScan 2200 to read the corresponding bar code.

If you do not find an interface number for your hardware configuration . . .

If your interface number is not among the predefined interface numbers provided below, you must compose the number yourself.

If you do not know which number to enter, contact your Intermec representative.

1. Use your MaxiScan 2200 to read the Compose Interface Number bar code:

Compose Interface Number

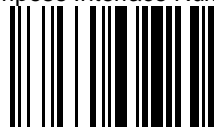

2. Read each digit of your interface number using the number codes provided at the end of this Installation Guide and scan the End Selection bar code—provided with the number codes—to finish.

Example To enter the number 102:

1. Scan Compose Interface Number.
2. Scan 1, then 0, then 2.
3. Scan End Selection.

Predefined interface numbers—Keyboard wedge

IBM PC AT and compatible

N° 200 - QWERTY - English

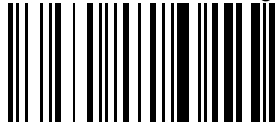

N° 201 - AZERTY - French

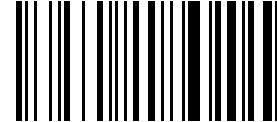

N° 204 - QWERTZ - German

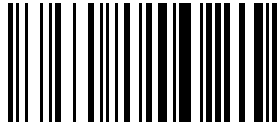

N° 205 - QWERTY - Swedish / Finnish



Predefined interface numbers—Keyboard wedge

IBM PC AT and compatible

N° 207 - QWERTY - Norwegian

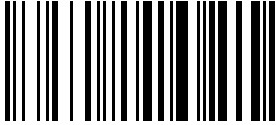

N° 208 - QWERTY - Danish

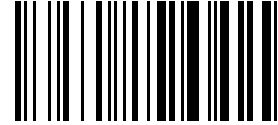

N° 2020 - QWERTZ - Swiss / French

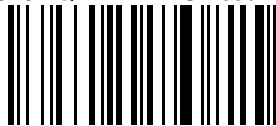

Predefined interface numbers—RS-232

N° 100 - Standard RS-232 C (9600, 7, E, 2)

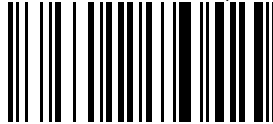

N° 101 - RS-232 TTL Level

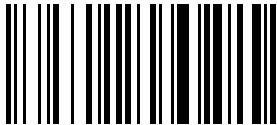

N° 102 - RS-232 PC Term

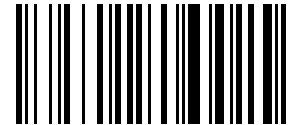

Predefined interface numbers—Wand emulation

N° 130 - Digital Wand Emulation

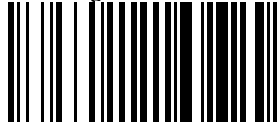

N° 131 - Analog Wand Emulation

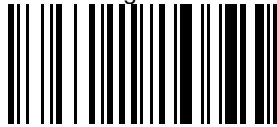

Predefined interface numbers—IBM 46xx cash registers

N° 110 - IBM 46xx cash registers—Port 9x



N° 111 - IBM 46xx cash registers—Port 5x



Predefined interface numbers—OCIA cash registers

N° 120 - OCIA TEC cash registers

First Type

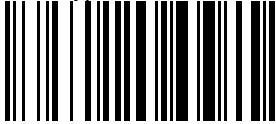

N° 121 - OCIA TEC cash registers

Second Type

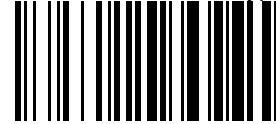

N° 122 - OCIA NCR cash registers

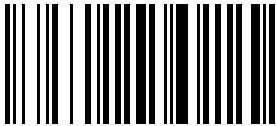

N° 123 - OCIA NCR 7052 cash registers

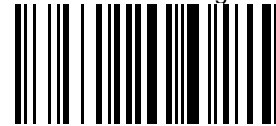

6 Enter the interface number for your system

7 Set up the data transmission parameters

data transmission parameters interface-specific communication parameters—in certain cases they need to be modified to optimize the performance of the MaxiScan 2200

Data transmission parameters

Scanning the interface number automatically configures your MaxiScan 2200 to suit your operating environment by modifying the data transmission settings.

This section provides some common data transmission settings for keyboard wedge and RS-232 interfaces—if you want to customize your data transmission settings, use your MaxiScan 2200 to read the corresponding bar codes.

Appendix E provides the full list of data transmission parameter settings for all the interfaces supported and indicates the predefined settings for some common interface numbers.

The full set of data transmission parameter options for all the interfaces supported is provided with the EasySet System scanner setup software and in the *MaxiScan 2200 Reference Manual*.

Resetting the predefined data transmission settings

If you want to reset all the predefined data transmission settings for your interface, rescan the appropriate interface number.

Keyboard wedge—Common data transmission parameters

The predefined parameter settings for standard keyboard wedge configurations are indicated by an asterisk (*).

Inter-character delay

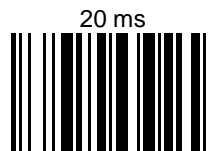
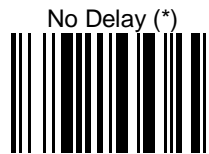

Keyboard wedge—Common data transmission parameters

End-of-message control codes (postamble)

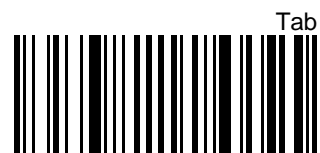
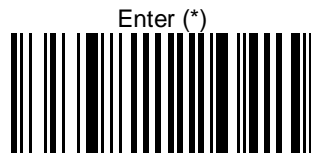

Keyboard wedge—Common data transmission parameters

End-of-message control codes (postamble)

Field Advance



Field Exit



No Postamble

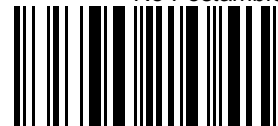

RS-232—Common data transmission parameters

The predefined parameter settings for standard RS-232 systems (interface number 100) are indicated by an asterisk (*).

Baud Rate

9600 (*)



19200

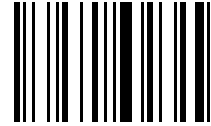

Data bits

Seven (*)



Eight



RS-232—Common data transmission parameters

Parity



RS-232—Common data transmission parameters

Stop bits

Two (*)



One

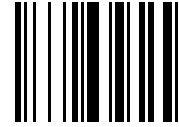

CTS/RTS (hardware)

Not Active (*)



Active



RS-232—Common data transmission parameters

Inter-character delay



RS-232—Common data transmission parameters

End-of-message control codes (postamble)

Carriage Return + Line Feed (*)

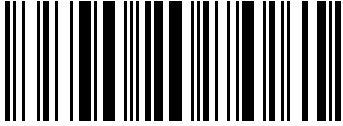

Carriage Return



Line Feed



No Postamble

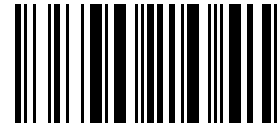

8 Set up the symbology parameters

<i>symbology</i>	bar code type or "family"—Code 39, UPC and EAN are examples of common symbologies
------------------	---

Symbologies and symbology parameters

The MaxiScan 2200 supports all the most common one-dimensional bar code symbologies.

This section provides the different symbology activation codes and some common parameter settings.

Code 39 and the UPC/EAN code families are preselected by default—if you want to select different symbologies or modify the parameter settings, use your MaxiScan 2200 to read the corresponding bar codes.

Appendix F provides the full list of parameter settings for all the symbologies supported and indicates the default settings for each symbology.

The full set of parameter options for all the symbologies supported is provided with the EasySet System scanner setup software and in the *MaxiScan 2200 Reference Manual*.

Resetting symbology default settings

When you install and set up your MaxiScan 2200 for the first time, all the symbology parameters are set to their factory default settings (see Appendix F).

The symbology default settings are global factory defaults—they are independent of the different symbology activation codes.

If you want to reset all the default symbology settings, you can scan the Reset Factory Defaults bar code provided in Appendix G, but you will then have to completely reconfigure your MaxiScan 2200.

In most cases, it is easier to perform the following symbology reset procedure:

1. Scan the Disable All Symbologies bar code.
2. Select the activation codes for the symbologies you want to read.
3. Customize the symbology parameter settings if required.

The Disable All Symbologies code deactivates all the symbologies activated. If you want to deactivate individual symbologies, use the Not Active codes for each symbology.

Disable All Symbologies does not reset the individual parameter settings for each symbology. When you reactivate a symbology, you recover the parameter settings stored in memory for that symbology when it was disabled.

Disable All Symbologies

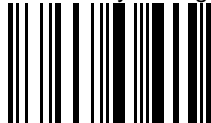

Symbology activation codes and common parameter settings

To optimize the performance of your MaxiScan 2200 and to ensure trouble-free scanning, do not select symbologies that you do not need.

If possible, do not select more than 2 symbologies at the same time—deactivate the Code 39 and UPC/EAN default symbologies if you do not need to use them.

Codabar	44
Code 39	46
Code 93	50
Code 128 / EAN 128	52
Interleaved 2 of 5	55
Matrix 2 of 5	57
MSI Code	59
Plessey Code	62
Standard 2 of 5	64
UPC/EAN code families (UPC-A, UPC-E, EAN-8, EAN-13)	66

By default, the minimum code length for all symbologies except UPC/EAN is 6 characters.

Configuration codes with an asterisk (*) are factory default settings.

Codabar

Activation

Not Active (*)



Active



Common parameter settings—Start/stop

Not Transmitted (*)

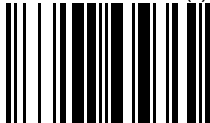

a, b, c, d

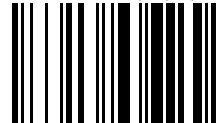

Codabar

Common parameter settings—Barcode length

Compose Minimum Length (default = 6)



Barcode length (number of characters) for Codabar = [start + barcode data + check digit if applicable + stop]. The minimum length possible is 3 characters.

For maximum security and to optimize reading performance, we recommend that you use one of the following parameters with the MaxiScan 2200:

- **Compose 1 or 2 or 3 Fixed Lengths (the best configuration if the codes in your application have fixed lengths),**
- **Compose Minimum Length.**

Compose different lengths using the special number codes provided at the end of this Installation Guide and scan End Selection once or twice as required:

minimum length:	Compose Minimum Length <length>—End Selection
1 fixed length:	Compose 1 or 2 or 3 Fixed Lengths <length>— End Selection—End Selection
2 fixed lengths:	Compose 1 or 2 or 3 Fixed Lengths <first length>—End Selection <second length>— End Selection—End Selection
3 fixed lengths:	Compose 1 or 2 or 3 Fixed Lengths <first length>—End Selection <second length>—End Selection <third length>— End Selection—End Selection

Compose 1 or 2 or 3 Fixed Lengths

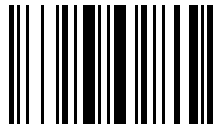

Code 39 (*)

Activation

Active (*)



Not Active

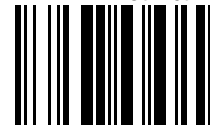

Standard 43 Characters (*)

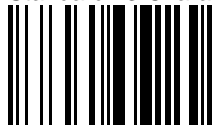

Full ASCII

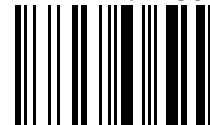

Code 39 (*)

Common parameter settings—Start/stop

Not Transmitted (*)



Transmitted



Common parameter settings—Check digit

Not Used (*)

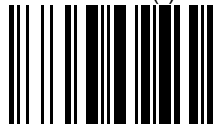

Code 39 (*)

Common parameter settings—Check digit

French CIP Check Digit
Checked And Transmitted

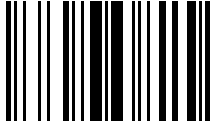

French CIP Check Digit
Checked But Not Transmitted

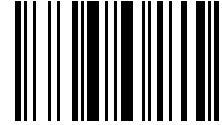

If the French CIP or Italian CPI check digits are used, the MaxiScan 2200 automatically performs code reconstruction to optimize reading.

Italian CPI Check Digit
Checked And Transmitted

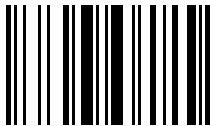

Italian CPI Check Digit
Checked But Not Transmitted

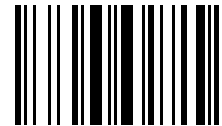

Code 39 (*)

Common parameter settings—Barcode length

Compose Minimum Length (default = 6)



Barcode length (number of characters) for Code 39 = [start + barcode data + check digit if applicable + stop]. The minimum length possible is 3 characters.

For maximum security and to optimize reading performance, we recommend that you use one of the following parameters with the MaxiScan 2200:

- **Compose 1 or 2 or 3 Fixed Lengths (the best configuration if the codes in your application have fixed lengths),**
- **Compose Minimum Length.**

Compose different lengths using the special number codes provided at the end of this Installation Guide and scan End Selection once or twice as required:

minimum length:	Compose Minimum Length <length>—End Selection
1 fixed length:	Compose 1 or 2 or 3 Fixed Lengths <length>— End Selection—End Selection
2 fixed lengths:	Compose 1 or 2 or 3 Fixed Lengths <first length>—End Selection <second length>— End Selection—End Selection
3 fixed lengths:	Compose 1 or 2 or 3 Fixed Lengths <first length>—End Selection <second length>—End Selection <third length>— End Selection—End Selection

Compose 1 or 2 or 3 Fixed Lengths

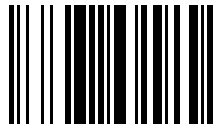

Code 93

Activation



Code 93

Common parameter settings—Barcode length

Compose Minimum Length (default = 6)



Barcode length (number of characters) for Code 93 = [barcode data]. The minimum length possible is 1 character.

For maximum security and to optimize reading performance, we recommend that you use one of the following parameters with the MaxiScan 2200:

- **Compose 1 or 2 or 3 Fixed Lengths (the best configuration if the codes in your application have fixed lengths),**
- **Compose Minimum Length.**

Compose different lengths using the special number codes provided at the end of this Installation Guide and scan End Selection once or twice as required:

minimum length:	Compose Minimum Length <length>—End Selection
1 fixed length:	Compose 1 or 2 or 3 Fixed Lengths <length>— End Selection—End Selection
2 fixed lengths:	Compose 1 or 2 or 3 Fixed Lengths <first length>—End Selection <second length>— End Selection—End Selection
3 fixed lengths:	Compose 1 or 2 or 3 Fixed Lengths <first length>—End Selection <second length>—End Selection <third length>— End Selection—End Selection

Compose 1 or 2 or 3 Fixed Lengths

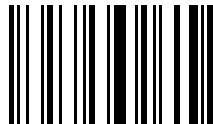

Code 128 / EAN 128

Activation

Not Active (*)



Active



New normalization allows decoding of the UCC/EAN standard extension. EAN 128 is auto-discriminating with Code 128 (recognition of the FNC1 start character used).

Common parameter settings—EAN 128 identifier

The]C1 AIM identifier for EAN 128 is automatically added by default in front of EAN 128 bar codes.

Include]C1 Identifier (*)

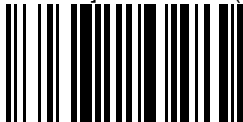

Remove]C1 Identifier

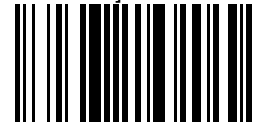

Code 128 / EAN 128

Common parameter settings—CIP 128 French pharmaceutical codes

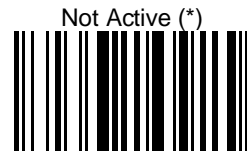

- embedded CIP 39 data
- fixed length 14 characters
- Code 128 character set C



Code 128 / EAN 128

Common parameter settings—Barcode length

Compose Minimum Length (default = 6)



Barcode length (number of characters) for Code 128 / EAN 128 = [barcode data]. The minimum length possible is 1 character.

Code 128 / EAN 128 does not use the same number of characters to code alphanumerical data and numerical data. If the MaxiScan 2200 does not read bar codes in your application, this may be due to unsuitable minimum or fixed lengths—try entering shorter lengths to get round this problem.

For maximum security and to optimize reading performance, we recommend that you use one of the following parameters with the MaxiScan 2200:

- **Compose 1 or 2 or 3 Fixed Lengths (the best configuration if the codes in your application have fixed lengths),**
- **Compose Minimum Length.**

Compose different lengths using the special number codes provided at the end of this Installation Guide and scan End Selection once or twice as required:

- | | |
|------------------|--|
| minimum length: | Compose Minimum Length
<length>—End Selection |
| 1 fixed length: | Compose 1 or 2 or 3 Fixed Lengths
<length>— End Selection—End Selection |
| 2 fixed lengths: | Compose 1 or 2 or 3 Fixed Lengths
<first length>—End Selection
<second length>— End Selection—End Selection |
| 3 fixed lengths: | Compose 1 or 2 or 3 Fixed Lengths
<first length>—End Selection
<second length>—End Selection
<third length>— End Selection—End Selection |

Compose 1 or 2 or 3 Fixed Lengths

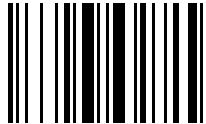

Interleaved 2 of 5

Activation



Interleaved 2 of 5

Common parameter settings—Barcode length

Compose Minimum Length (default = 6)



Barcode length (number of characters) for Interleaved 2 of 5 = [barcode data + check digit if applicable]. The minimum length possible is 2 characters.

Interleaved 2 of 5 always encodes an even number of characters. To handle codes with an odd number of characters, the MaxiScan 2200 will accept a code with the last character printed as 5 narrow bars. In this case, all useful characters are transmitted.

For maximum security and to optimize reading performance, we recommend that you use one of the following parameters with the MaxiScan 2200:

- **Compose 1 or 2 or 3 Fixed Lengths (the safest configuration),**
- **Compose Minimum Length.**

Compose different lengths using the special number codes provided at the end of this Installation Guide and scan End Selection once or twice as required:

minimum length: Compose Minimum Length
 <length>—End Selection

1 fixed length: Compose 1 or 2 or 3 Fixed Lengths
 <length>—**End Selection—End Selection**

2 fixed lengths: Compose 1 or 2 or 3 Fixed Lengths
 <first length>—End Selection
 <second length>—**End Selection—End Selection**

3 fixed lengths: Compose 1 or 2 or 3 Fixed Lengths
 <first length>—End Selection
 <second length>—End Selection
 <third length>—**End Selection—End Selection**

Compose 1 or 2 or 3 Fixed Lengths

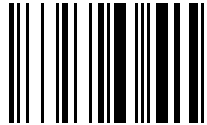

Matrix 2 of 5

Activation

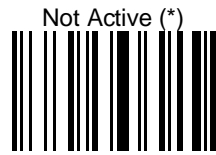

Matrix 2 of 5

Common parameter settings—Barcode length

Compose Minimum Length (default = 6)

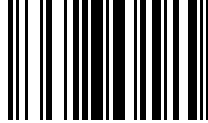

Barcode length (number of characters) for Matrix 2 of 5 = [barcode data]. The minimum length possible is 3 characters.

For maximum security and to optimize reading performance, we recommend that you use one of the following parameters with the MaxiScan 2200:

- **Compose 1 or 2 or 3 Fixed Lengths (the best configuration if the codes in your application have fixed lengths),**
- **Compose Minimum Length.**

Compose different lengths using the special number codes provided at the end of this Installation Guide and scan End Selection once or twice as required:

minimum length:	Compose Minimum Length <length>—End Selection
1 fixed length:	Compose 1 or 2 or 3 Fixed Lengths <length>— End Selection—End Selection
2 fixed lengths:	Compose 1 or 2 or 3 Fixed Lengths <first length>—End Selection <second length>— End Selection—End Selection
3 fixed lengths:	Compose 1 or 2 or 3 Fixed Lengths <first length>—End Selection <second length>—End Selection <third length>— End Selection—End Selection

Compose 1 or 2 or 3 Fixed Lengths

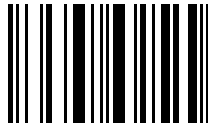

MSI Code

Activation

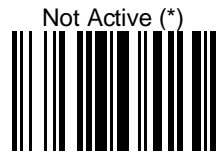

MSI Code

Common parameter settings—Check Digit Mod 10

Checked And Transmitted (*)

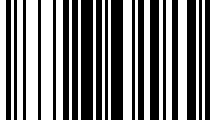

Checked But Not Transmitted



Common parameter settings—Check Digit Double Mod 10

Checked And Transmitted

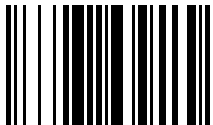

Checked But Not Transmitted

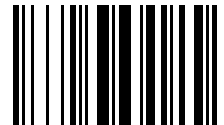

MSI Code

Common parameter settings—Barcode length

Compose Minimum Length (default = 6)

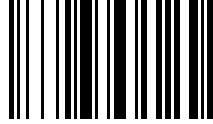

Barcode length (number of characters) for MSI Code = [barcode data + check digit]. The minimum length possible is 2 characters.

For maximum security and to optimize reading performance, we recommend that you use one of the following parameters with the MaxiScan 2200:

- **Compose 1 or 2 or 3 Fixed Lengths (the best configuration if the codes in your application have fixed lengths),**
- **Compose Minimum Length.**

Compose different lengths using the special number codes provided at the end of this Installation Guide and scan End Selection once or twice as required:

minimum length:	Compose Minimum Length <length>—End Selection
1 fixed length:	Compose 1 or 2 or 3 Fixed Lengths <length>— End Selection—End Selection
2 fixed lengths:	Compose 1 or 2 or 3 Fixed Lengths <first length>—End Selection <second length>— End Selection—End Selection
3 fixed lengths:	Compose 1 or 2 or 3 Fixed Lengths <first length>—End Selection <second length>—End Selection <third length>— End Selection—End Selection

Compose 1 or 2 or 3 Fixed Lengths

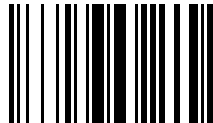

Plessey Code

Activation

Not Active (*)



Active

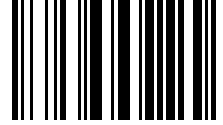

Common parameter settings—Check digit

Transmitted (*)

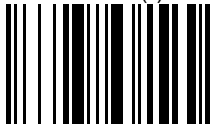

Not Transmitted

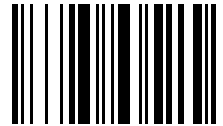

Plessey Code

Common parameter settings—Barcode length

Compose Minimum Length (default = 6)

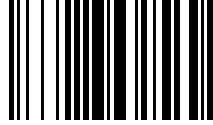

Barcode length (number of characters) for Plessey Code = [start + barcode data + 2-character check digit + stop]. The minimum length possible is 5 characters. The maximum length possible is 25 characters.

For maximum security and to optimize reading performance, we recommend that you use one of the following parameters with the MaxiScan 2200:

- **Compose 1 or 2 or 3 Fixed Lengths (the best configuration if the codes in your application have fixed lengths),**
- **Compose Minimum Length.**

Compose different lengths using the special number codes provided at the end of this Installation Guide and scan End Selection once or twice as required:

minimum length:	Compose Minimum Length <length>—End Selection
1 fixed length:	Compose 1 or 2 or 3 Fixed Lengths <length>— End Selection—End Selection
2 fixed lengths:	Compose 1 or 2 or 3 Fixed Lengths <first length>—End Selection <second length>— End Selection—End Selection
3 fixed lengths:	Compose 1 or 2 or 3 Fixed Lengths <first length>—End Selection <second length>—End Selection <third length>— End Selection—End Selection

Compose 1 or 2 or 3 Fixed Lengths

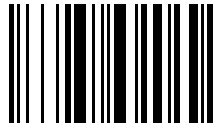

Standard 2 of 5

Activation



Standard 2 of 5 is also referred to as "Straight 2 of 5" and "Industrial 2 of 5".

Active (default format = Identicon)

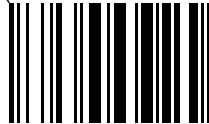

Standard 2 of 5

Common parameter settings—Barcode length

Compose Minimum Length (default = 6)



Barcode length (number of characters) for Standard 2 of 5 = [barcode data + check digit if applicable]. The minimum length possible is 3 characters.

For maximum security and to optimize reading performance, we recommend that you use one of the following parameters with the MaxiScan 2200:

- **Compose 1 or 2 or 3 Fixed Lengths (the best configuration if the codes in your application have fixed lengths),**
- **Compose Minimum Length.**

Compose different lengths using the special number codes provided at the end of this Installation Guide and scan End Selection once or twice as required:

minimum length:	Compose Minimum Length <length>—End Selection
1 fixed length:	Compose 1 or 2 or 3 Fixed Lengths <length>— End Selection—End Selection
2 fixed lengths:	Compose 1 or 2 or 3 Fixed Lengths <first length>—End Selection <second length>— End Selection—End Selection
3 fixed lengths:	Compose 1 or 2 or 3 Fixed Lengths <first length>—End Selection <second length>—End Selection <third length>— End Selection—End Selection

Compose 1 or 2 or 3 Fixed Lengths

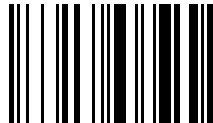

UPC/EAN code families (UPC-A, UPC-E, EAN-8, EAN-13) (*)

Activation

Active—UPC/EAN (*)

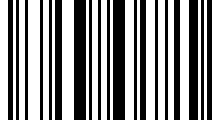

Not Active—UPC/EAN



UPC-A Transmitted as EAN-13 (*)

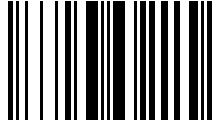

UPC-A Transmitted as UPC-A



UPC/EAN code families (UPC-A, UPC-E, EAN-8, EAN-13) (*)

Common parameter settings—Add-on digits

Not Required But Transmitted If Read (*)

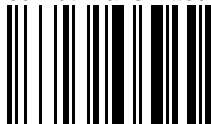

Required And Transmitted



UPC/EAN code families (UPC-A, UPC-E, EAN-8, EAN-13) (*)

Common parameter settings—Add-on digits

Add-On 2 Not Active (*)

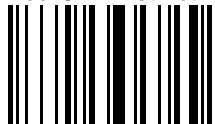

Add-On 2 Active



Add-On 5 Not Active (*)



Add-On 5 Active



UPC/EAN code families (UPC-A, UPC-E, EAN-8, EAN-13) (*)

Common parameter settings—Check digit

UPC-A Check Digit—Transmitted (*)

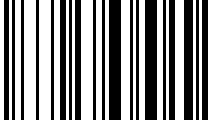

UPC-A Check Digit—Not Transmitted



UPC/EAN code format: <leading character> <number system> <data> <check digit>

UPC-E Check Digit—Transmitted (*)



UPC-E Check Digit—Not Transmitted



UPC/EAN code families (UPC-A, UPC-E, EAN-8, EAN-13) (*)

Common parameter settings—Check digit

EAN-8 Check Digit—Transmitted (*)



EAN-8 Check Digit—Not Transmitted

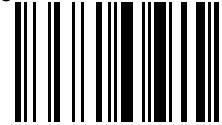

UPC/EAN code format: <leading character> <number system> <data> <check digit>

EAN-13 Check Digit—Transmitted (*)

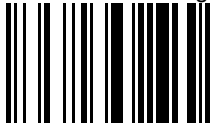

EAN-13 Check Digit—Not Transmitted

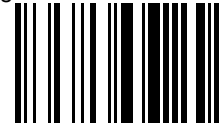

UPC/EAN code families (UPC-A, UPC-E, EAN-8, EAN-13) (*)

Common parameter settings—Transmission of number system

UPC-A Number System—Transmitted (*)

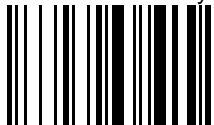

UPC-A Number System—Not Transmitted

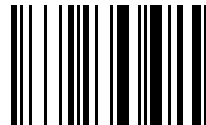

UPC/EAN code format: <leading character> <number system> <data> <check digit>

A regular UPC-A has a transmitted number system equal to 0. To transmit the additional leading character (country code), select the parameter UPC-A Transmitted As EAN-13.

UPC-E Number System—Transmitted (*)

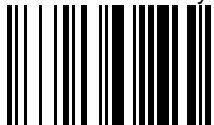

UPC-E Number System—Not Transmitted



9 Set up the operating parameters

*operating
parameters*

parameters that affect the way the MaxiScan 2200 operates—general operating parameters include resolution adjustment (video channel selection), depth of field, scan rate, standby mode settings, beep characteristics

MaxiScan 2200 operating parameters

Now that you have entered your interface number and set up your data transmission and symbology parameters, you are ready to use your MaxiScan 2200 in most working situations.

You may now wish to change some operating parameters. Use your MaxiScan 2200 to read the appropriate operating parameter codes provided on the following pages.

Appendix G provides the full list of MaxiScan 2200 operating parameter settings.

The full set of MaxiScan 2200 operating parameter options is provided with the EasySet System scanner setup software and in the *MaxiScan 2200 Reference Manual*.

Resetting the default MaxiScan 2200 operating settings

If you want to reset all the default MaxiScan 2200 operating settings, you can scan the Reset Factory Defaults bar code provided in Appendix G, but you will then have to completely reconfigure your MaxiScan 2200.

In most cases, it is easier to reselect the individual settings as required.

Resolution adjustment (video channel selection)

High-Resolution / Low-Resolution Video Channels (*)

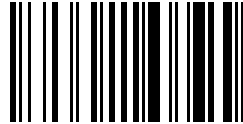

By default, the MaxiScan 2200 is set to switch continuously between the high- and low-resolution video channels. The video channel changes with each new scan and normal-quality medium-resolution bar codes such as standard EAN (100%) are read easily by both video channels.

For more “difficult” bar codes, you will greatly optimize reading by selecting the appropriate video channel (High-Resolution or Low-Resolution) for the bar codes you want to read.

bar codes you want to read	video channel selection
normal-quality medium-resolution bar codes such as standard EAN (100% magnitude)	High-Resolution / Low-Resolution Video Channels (*)
high-density bar codes (narrow bar width < 0.2 mm)	High-Resolution Video Channel
<ul style="list-style-type: none"> • ultra-low-density bar codes (narrow bar width > 1 mm) • bar codes printed with a dot-matrix printer • poorly printed bar codes 	Low-Resolution Video Channel

High-Resolution Video Channel

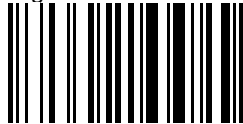

Low-Resolution Video Channel

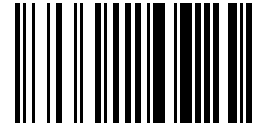

Reading distance

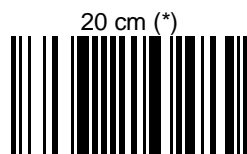

You can change the maximum reading distance of the MaxiScan 2200 to make sure that you only read codes within the specified range.

The reading distances provided here are valid for normal-quality medium-resolution bar codes such as standard EAN (100% magnitude).

10 cm (UPC/EAN 100% only)

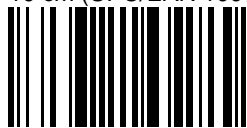

15 cm

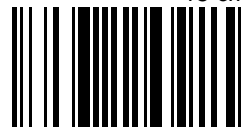

Scan rate

1400 Scans Per Second (*)

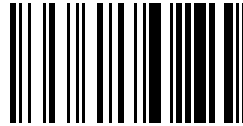

The default scan rate of 1400 scans per second is suitable for normal-quality medium-resolution bar codes such as standard EAN (100%).

For other reading situations, you will optimize reading performance by finding the best scan rate for the bar codes you want to read.

reading situation	scan rate
normal-quality medium-resolution bar codes such as standard EAN (100% magnitude)	1400 Scans Per Second (*)
increased reading range for high-density bar codes (narrow bar width between 0.125 mm and 0.2 mm)	1200 Scans Per Second
fast reading of normal-quality UPC/EAN bar codes	1600 Scans Per Second

1200 Scans Per Second



1600 Scans Per Second

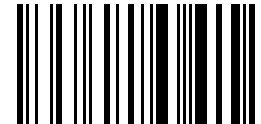

Standby mode

Standby Mode Enable (*)



Standby mode increases the lifetime of the laser diode (initial standby) and rotating mirror motor (full standby):

- after an initial period of inactivity (T), the laser beam is switched off automatically,
- after an additional period of inactivity ($T \times 2$)—and a total period of inactivity $T \times 3$ —the rotating mirror motor is switched off.

The MaxiScan 2200 is reactivated when you try to read a new bar code. Wake-up is quicker after initial standby than after full standby.

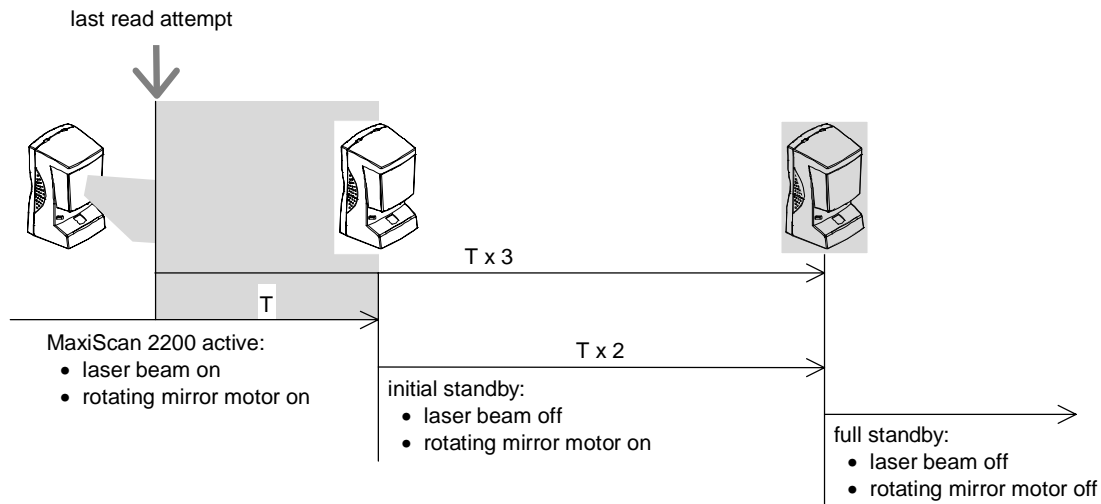

Standby Mode Disable



Initial Standby After 15 Minutes (*)



Default values before standby:

- initial standby: the laser beam is switched off after $T = 15$ minutes (900 seconds),
- full standby: the rotating mirror motor is switched off after an additional period of $T \times 2 = 30$ minutes and a total period of inactivity of $T \times 3 = 45$ minutes.

Composing a different time before standby

1. Use your MaxiScan 2200 to read the Compose Time In Seconds Before Initial Standby bar code.
2. Read each digit of the new time before initial standby using the number codes provided at the end of this Installation Guide and scan the End Selection bar code—provided with the number codes—to finish.

Example To change the time before initial standby to 10 minutes (600 seconds):

1. Scan Compose Time In Seconds Before Initial Standby.
2. Scan 6, then 0, then 0.
3. Scan End Selection.

The MaxiScan 2200 will go into initial standby after 10 minutes and full standby after a total of 30 minutes after the last read attempt.

Compose Time In Seconds Before Initial Standby



Beep characteristics

Read the following codes to change the beeper volume and musical note (tone frequency).

Beeper volume



Beeper note

High (2093.04 Hz, 478 μ s) (*)

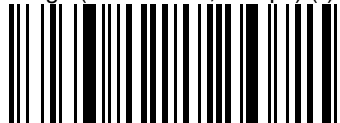

Low (1318.52 Hz, 758 μ s)

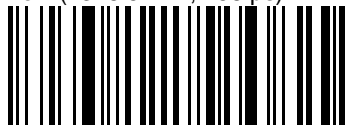

Medium (1760 Hz, 568 μ s)



A Installing the optional adjustable stand

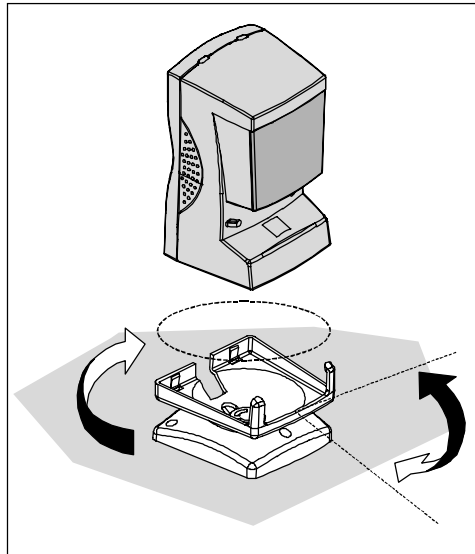

Important remarks

The optional adjustable stand allows the MaxiScan 2200 to read items at a fixed reading angle. The MaxiScan 2200 is clipped in and out of the adjustable stand, so you can still use it as a hand scanner if required.

Remember to take into account the length of the operating cables and power supply cable when you install the MaxiScan 2200.

Do not remove the protective film from the red reading window until you have finished installing the MaxiScan 2200.

Do not try to dismount the MaxiScan 2200 except as specified in this Installation Guide and always use the scanner only as described in MaxiScan 2200 documentation.

Adjustable stand—Installation examples

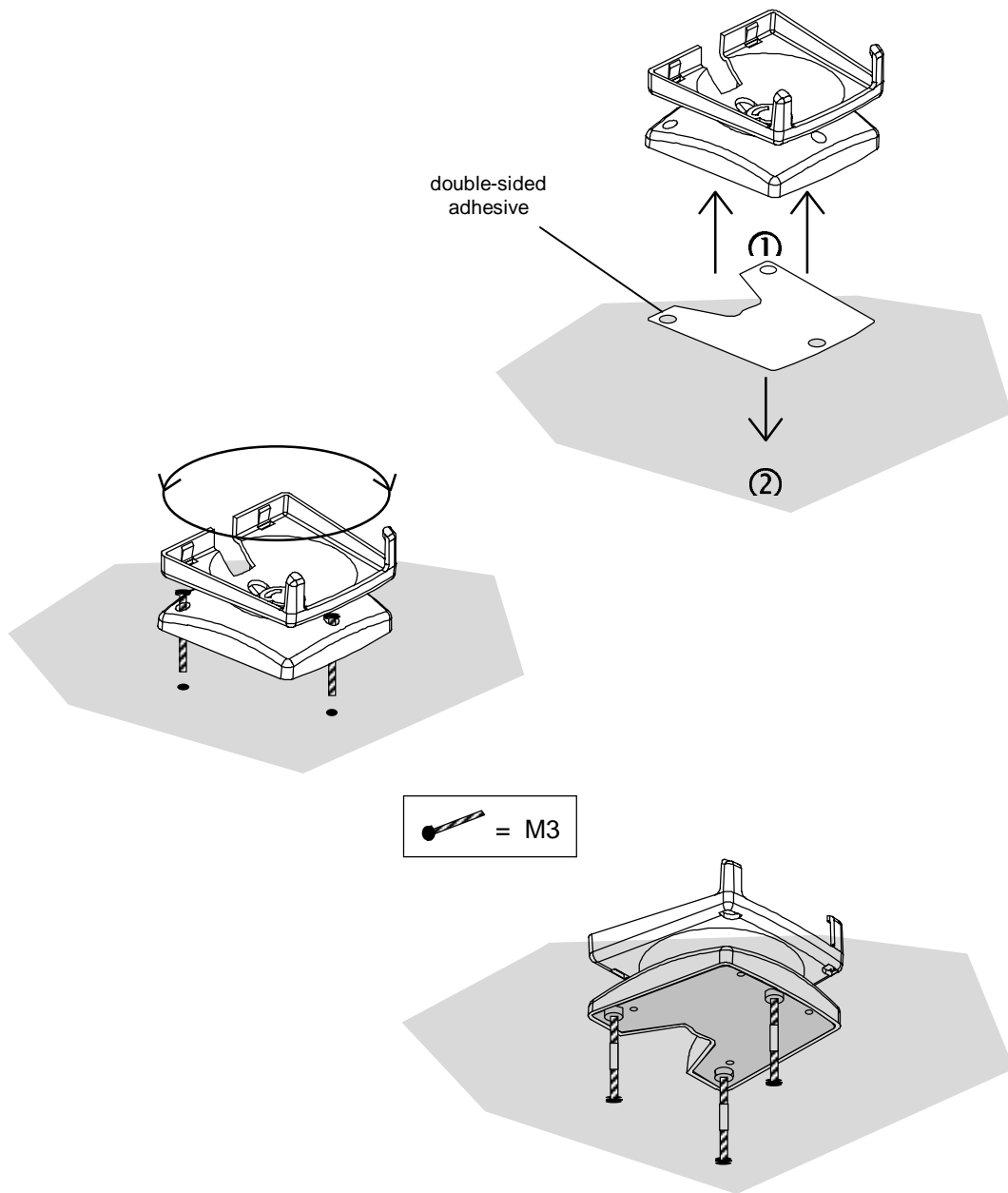

B Installing the MaxiScan 2200 in a fixed reading position

Important remarks

For a fixed location, you can screw the MaxiScan 2200 directly to the work surface or use the special mounting plate provided in the MaxiScan 2200 product package

Remember to take into account the length of the operating cables and power supply cable when you install the MaxiScan 2200.

Do not remove the protective film from the red reading window until you have finished installing the MaxiScan 2200.

Do not try to dismount the MaxiScan 2200 except as specified in this Installation Guide and always use the scanner only as described in MaxiScan 2200 documentation.

Direct installation

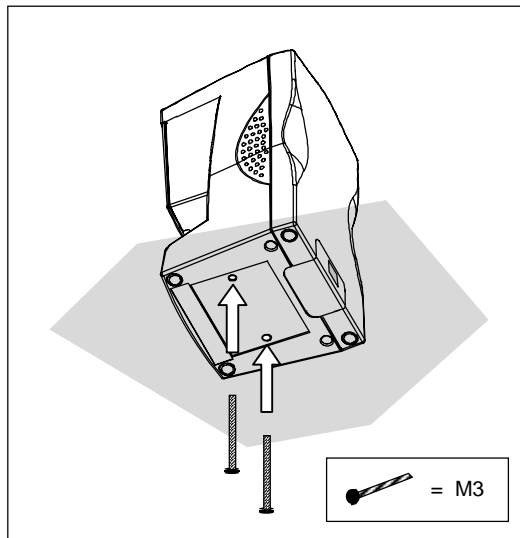

Mounting plate—Installation examples

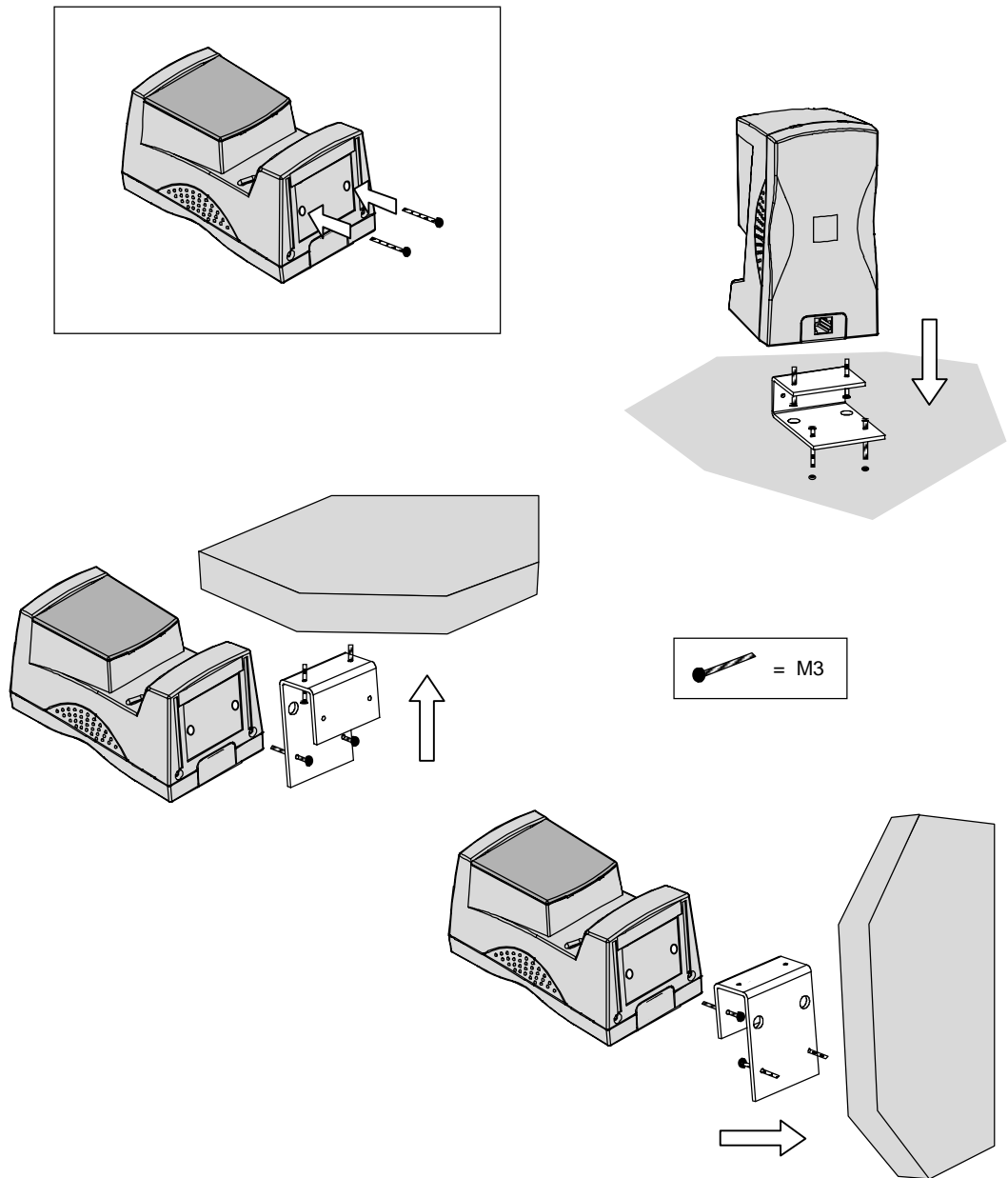

C Changing the cable connector position

Important remarks

If you use the optional adjustable stand or fixed-position mounting plate, you may need to change the cable connector position from horizontal to vertical (or back from vertical to horizontal!).

Remember to take into account the length of the operating cables and power supply cable when you install the MaxiScan 2200.

Do not remove the protective film from the red reading window until you have finished installing the MaxiScan 2200.

Do not try to dismount the MaxiScan 2200 except as specified in this Installation Guide and always use the scanner only as described in MaxiScan 2200 documentation.

Horizontal to vertical

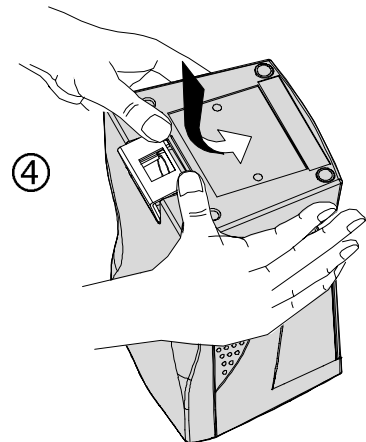
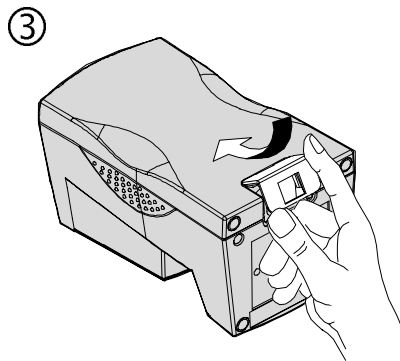
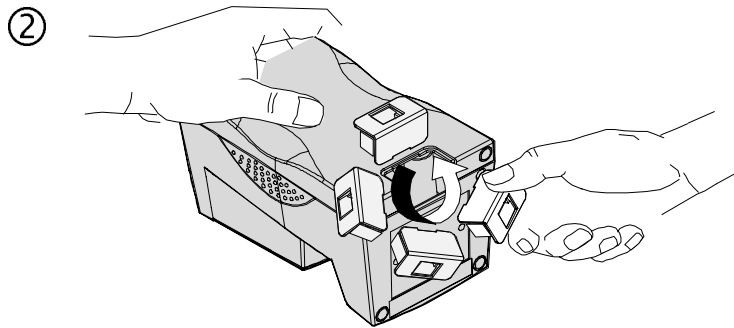
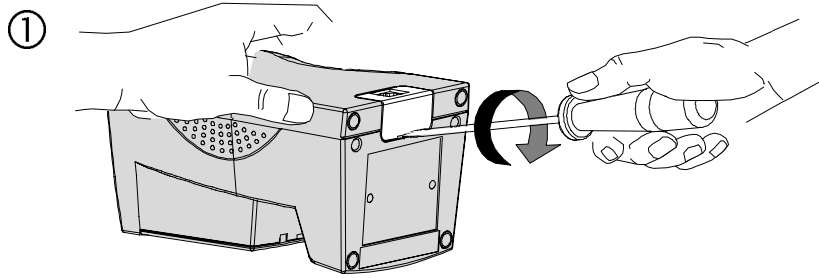
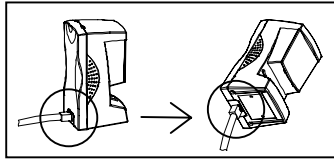

Vertical to horizontal

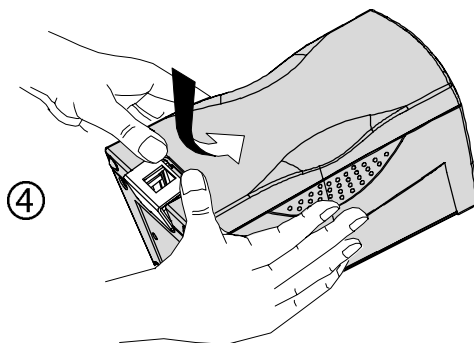
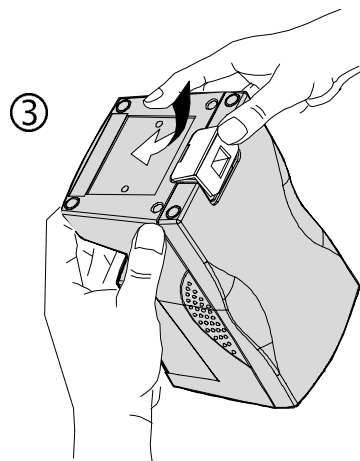
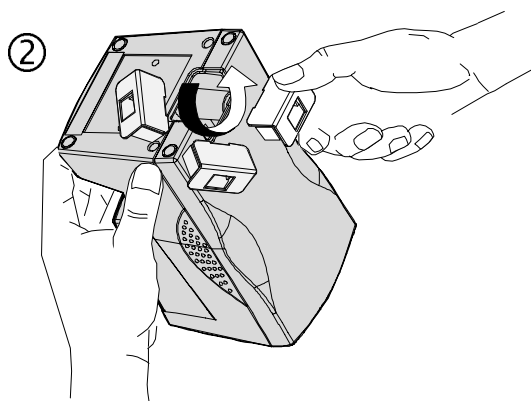
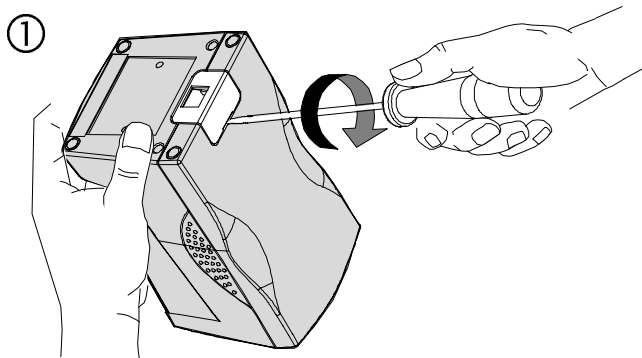
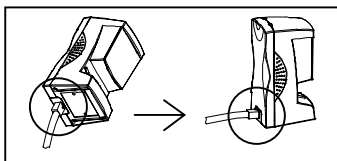

D Care and replacement of the red reading window

Looking after the red reading window

Make sure that the red reading window is always clean (no finger marks or stains) and undamaged. A replacement window is provided in the product package. You can order more red reading windows from your Intermecc distributor.

Do not use liquid cleaning products to clean the red reading window—use only a soft optician's cleaning cloth.

You must change the red reading window if it is damaged (scratched or broken).

Changing the window

Important precautions!

Always disconnect the electrical power before you work on the MaxiScan 2200.

Do not remove the protective film from the red reading window until you have finished the window replacement procedure.

When you remove the red reading window:

- **make sure that no dirt or objects fall into the MaxiScan 2200,**
- **do not touch any internal parts (silver mirrors, gold rotating mirror, etc.).**

Do not try to dismount the MaxiScan 2200 except as specified in this Installation Guide and always use the scanner only as described in MaxiScan 2200 documentation.

Window replacement procedure

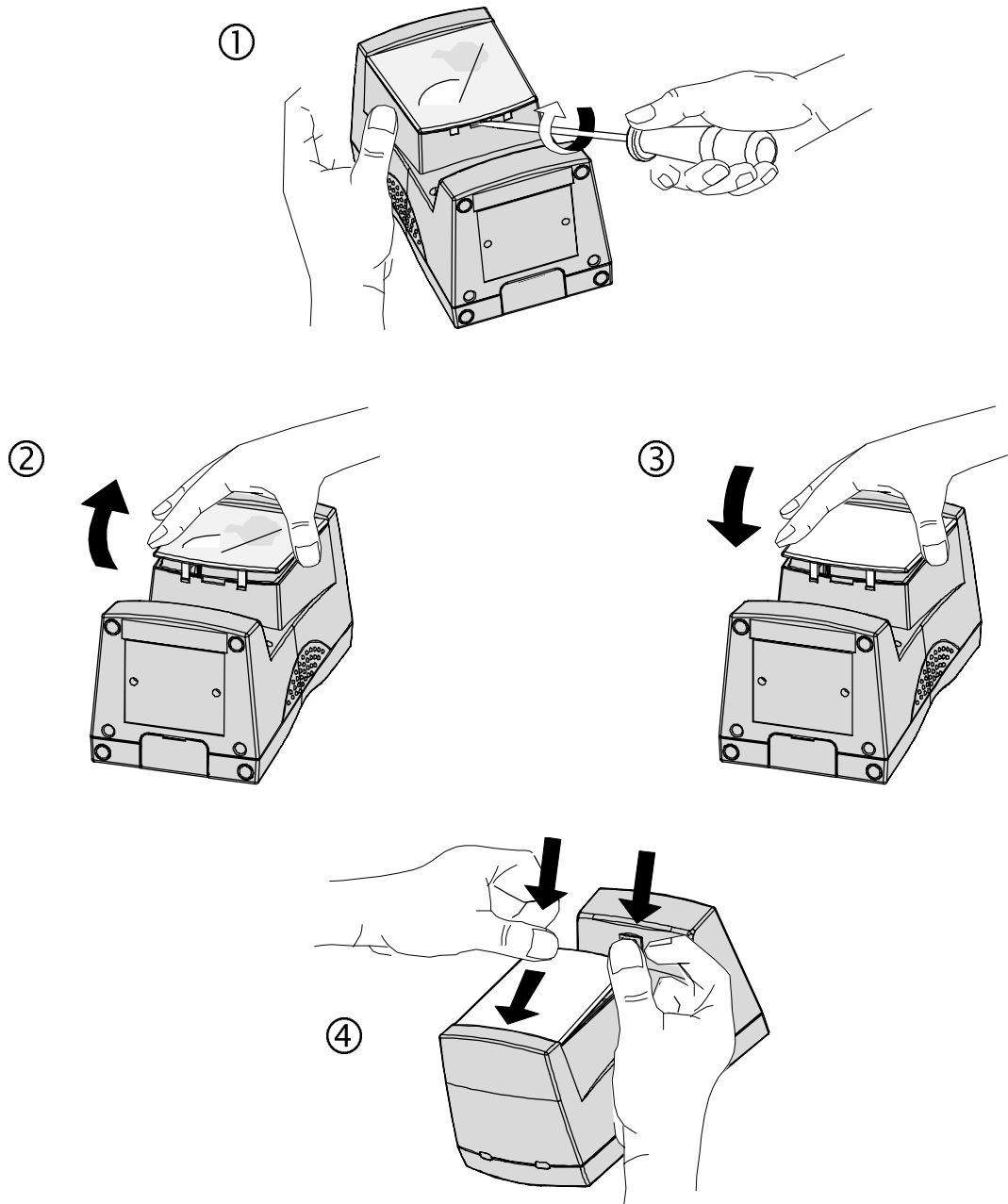

E Data transmission parameters

The full set of data transmission parameter options for all the interfaces supported is provided with the EasySet System scanner setup software and in the *MaxiScan 2200 Reference Manual*.

Keyboard wedge

An asterisk (*) indicates the predefined parameter settings for keyboard wedge interface N° 200 (QWERTY - English).

- preamble - no preamble (*)
 - user-defined
- postamble - Enter (*)
 - Carriage Return
 - Tab
 - Field Advance
 - Field Exit
 - Down Arrow
 - user-defined
 - no postamble
- code marks - not transmitted (*)
 - transmitted
 - default / user-defined
- special keys transmission - Alt mode off (*)
 - Alt mode on
- end-of-transmission keyboard character status - lower case (*)
 - upper case
- inter-character delay - none (*)
 - 1 to 999 ms
- inter-message delay - none (*)
 - 1 to 999 ms

RS-232

An asterisk (*) indicates the predefined parameter settings for interface N° 100 (Standard RS-232 C).

baud rate	- 9600 (*)
	- 75 - 150 - 300 - 600 - 1200 - 2400 - 4800 - 19200 - 38400
data bits	- 7 (*)
	- 8
parity	- even (*)
	- odd
	- none
stop bits	- 2 (*)
	- 1
ENQ (Hex 05)	- not used (*)
	- ENQ (HEX 05)
	- user-defined
ACK (Hex 06)	- not used (*)
	- ACK (HEX 06)
	- user-defined
NAK (Hex 15)	- not used (*)
	- NAK (HEX 15)
	- user-defined
XON/XOFF software protocol	- not active (*)
	- active
CTS/RTS hardware protocol	- not active (*)
	- active
time-out (hardware and software)	- 1000 ms (*)
	- unlimited
	- user-defined 1 to 2500 ms
preamble	- no preamble (*)
	- user-defined
postamble	- Carriage Return + Line Feed (*)
	- Carriage Return
	- Line Feed
	- user-defined
	- no postamble
preamble + postamble	- STX + ETX
code marks	- not transmitted (*)
	- transmitted
	- default / user-defined
inter-character delay	- none (*)

- 1 to 999 ms
- inter-message delay - none (*)
- 1 to 999 ms

IBM 46xx cash registers

The main predefined parameter settings for IBM 46xx cash registers depend on cash register protocols and can not be modified.

An asterisk (*) indicates the predefined transmission delay setting for interface N° 110 / N° 111 (IBM 46xx cash registers—Port 9x / Port 5x).

- inter-message delay - none (*)
- 1 to 999 ms

OCIA cash registers

The main predefined parameter settings for OCIA cash registers depend on cash register protocols and can not be modified.

An asterisk (*) indicates the predefined transmission delay settings for interface N° 120 / N° 121 / N° 122 (OCIA cash registers—TEC First Type / TEC Second Type / NCR).

- inter-character delay - none (*)
- 1 to 999 ms
- inter-message delay - none (*)
- 1 to 999 ms

Wand emulation

An asterisk (*) indicates the predefined parameter settings for interface N° 130 (digital wand emulation).

- inter-message delay - none (*)
- 1 to 999 ms
- margin size - 10 x narrow bar width (*)
- user-defined
- logical signal state during transmission - bar = 1, space = 0, margin = 0 (*)
- bar = 0, space = 1, margin = 1
- logical signal state outside transmission - quiet zone = 0 (*)
- quiet zone = 1

- pulse duration - 0.88 ms (37.5 cm/s) (*)
- 0.19 ms (175 cm/s) - 0.26 ms (125 cm/s) - 0.44 ms (75 cm/s) - 0.66 ms (50 cm/s) - 1.32 ms (25 cm/s) - 2.64 ms (12.5 cm/s) - 6.60 ms (5 cm/s)

F Symbology parameters

An asterisk (*) indicates the factory default settings for each symbology.

The full set of parameter options for all the symbologies supported is provided with the EasySet System scanner setup software and in the *MaxiScan 2200 Reference Manual*.

Codabar

- activation - not active (*)
 - active
- start/stop - not transmitted (*)
 - a, b, c, d
 - A, B, C, D
 - a, b, c, d / t, n, *, e
 - DC1, DC2, DC3, DC4
- CLSI library system - not active (*)
 - active
 - no spaces
- check digit (AIM recommendation) - not used (*)
 - checked and transmitted
 - checked but not transmitted
- barcode length (number of characters) - minimum length = 6 (*)
 - return to current minimum length
 - user-defined minimum length
 - user-defined 1 or 2 or 3 fixed lengths

Code 39

- activation - active (*)
 - not active
- Code 39 format - standard 43 characters (*)
 - full ASCII
- start/stop - not transmitted (*)
 - transmitted
- check digit - not used (*)
- modulo 43 check digit - checked and transmitted
 - checked but not transmitted
- French CIP check digit - checked and transmitted
 - checked but not transmitted

- Italian CPI check digit - checked and transmitted
- checked but not transmitted
- barcode length (number of characters) - minimum length = 6 (*)
- return to current minimum length
- user-defined minimum length
- user-defined 1 or 2 or 3 fixed lengths

Code 93

- activation - not active (*)
- active
- barcode length (number of characters) - minimum length = 6 (*)
- return to current minimum length
- user-defined minimum length
- user-defined 1 or 2 or 3 fixed lengths

Code 128 / EAN 128

- activation - not active (*)
- active
- CIP 128 French pharmaceutical codes - not active (*)
- active
- FNC1 separator character—EAN-128 norms - user-defined (GS character (ASCII 29) by default)
- barcode length (number of characters) - minimum length = 6 (*)
- return to current minimum length
- user-defined minimum length
- user-defined 1 or 2 or 3 fixed lengths

Interleaved 2 of 5

- activation - not active (*)
- active
- check digit - not used (*)
- check digit mod 10 - checked and transmitted
- checked but not transmitted
- French CIP HR check digit - checked and transmitted
- checked but not transmitted
- barcode length (number of characters) - minimum length = 6 (*)
- return to current minimum length
- user-defined minimum length
- user-defined 1 or 2 or 3 fixed lengths

Matrix 2 of 5

- activation - not active (*)
- active
- barcode length (number of characters) - minimum length = 6 (*)
- return to current minimum length
- user-defined minimum length
- user-defined 1 or 2 or 3 fixed lengths

MSI Code

- activation - not active (*)
- active
- check digit mod 10 - checked and transmitted (*)
- checked but not transmitted
- check digit double mod 10 - checked and transmitted
- checked but not transmitted
- barcode length (number of characters) - minimum length = 6 (*)
- return to current minimum length
- user-defined minimum length
- user-defined 1 or 2 or 3 fixed lengths

Plessey Code

- activation - not active (*)
- active
- check digit - transmitted (*)
- not transmitted
- barcode length (number of characters) - minimum length = 6 (*)
- return to current minimum length
- user-defined minimum length
- user-defined 1 or 2 or 3 fixed lengths

Standard 2 of 5

Standard 2 of 5 is also referred to as "Straight 2 of 5" and "Industrial 2 of 5".

- activation - not active (*)
- active
- start/stop bars - Identicon (6 start / stop bars) (*)
- Computer Identics (4 start / stop bars)

- check digit mod 10
 - not used (*)
 - checked and transmitted
 - checked but not transmitted
- barcode length (number of characters)
 - minimum length = 6 (*)
 - return to current minimum length
 - user-defined minimum length
 - user-defined 1 or 2 or 3 fixed lengths

UPC/EAN code families (UPC-A, UPC-E, EAN-8, EAN-13)

- activation
 - active (*)
 - not active
- UPC/EAN format deactivation
 - UPC-A deactivated
 - UPC-E deactivated
 - EAN-8 deactivated
 - EAN-13 deactivated
- add-on digits
 - not required but transmitted if read (*)
 - required and transmitted
- add-on 2
 - not active (*)
 - active
- add-on 5
 - not active (*)
 - active
- UPC-A check digit
 - transmitted (*)
 - not transmitted
- UPC-E check digit
 - transmitted (*)
 - not transmitted
- EAN-8 check digit
 - transmitted (*)
 - not transmitted
- EAN-13 check digit
 - transmitted (*)
 - not transmitted
- UPC-A number system
 - transmitted (*)
 - not transmitted
- UPC-E number system
 - transmitted (*)
 - not transmitted
- re-encoding UPC-A, UPC-E, EAN-8
 - UPC-A transmitted as EAN-13 (*)
 - UPC-A transmitted as UPC-A
 - UPC-E transmitted as UPC-E (*)
 - UPC-E transmitted as UPC-A
 - EAN-8 transmitted as EAN 8 (*)
 - EAN-8 transmitted as EAN-13

G MaxiScan 2200 operating parameters

Factory default settings are indicated by an asterisk (*).

The full set of MaxiScan 2200 operating parameter options is provided with the EasySet System scanner setup software and in the *MaxiScan 2200 Reference Manual*.

Interfaces

- interfaces
 - null interface (*)
(no interface driver selected—no transmission)
 - keyboard wedge
 - RS-232 C
 - RS-232 TTL
 - IBM 46xx cash registers
 - OCIA cash registers
 - wand emulation
- interface-specific parameters - see Appendix E

Symbologies

- symbologies
 - Codabar
 - Code 39 (*)
 - Code 128 / EAN 128
 - Interleaved 2 of 5
 - Matrix 2 of 5
 - MSI Code
 - Plessey Code
 - Standard 2 of 5
 - UPC/EAN code families (UPC-A, UPC-E, EAN-8, EAN-13)
(*)
- symbology-specific parameters - see Appendix F

General operating parameters

- Resolution adjustment (video channel selection)
 - High-Resolution / Low-Resolution Video Channels (*)
 - High-Resolution Video Channel
 - Low-Resolution Video Channel
- Reading distance
 - 20 cm (*)
 - 10 cm (UPC/EAN 100% only)

- 15 cm
- Scan rate - 1400 Scans Per Second (*)
- 1200 Scans Per Second
- 1600 Scans Per Second
- Standby mode - Standby Mode Enable (*)
- Standby Mode Disable
- Initial Standby After 15 Minutes (*)
- User-defined Time In Seconds Before Initial Standby

Beeps

- power-up beeps - on (*)
- off
- good read beeps - 1beep (*)
- 2 beeps
- no beep
- timing of good read beeps - before transmission (*)
- after transmission
- duration of good read beeps - 80 ms (*)
- 60 ms
- 200 ms
- 300 ms
- user-defined (0 to 999 ms)
- Beeper volume - High Volume (*)
- Low Volume
- Beeper note - High (2093.04 Hz, 478 μ s) (*)
- Medium (1760 Hz, 568 μ s)
- Low (1318.52 Hz, 758 μ s)

Configuration modes

- configuration authorization modes - enable (*)
- configuration inhibit after 4 mn
- temporary configuration mode - enable
- restore current configuration
- update current configuration
- display data string mode - enable
- EEPROM error messages - display (keyboard wedge and RS-232)
- flush

Data decoding security parameters

- predefined security levels
 - normal security level (*)
 - medium security level
 - high security level
- consecutive same read data validation
 - single read before transmission (*)
 - user-defined number of consecutive same reads before transmission
- time-out between identical consecutive codes
 - 500 ms (*)
 - user-defined
- time-out between different consecutive codes
 - 500 ms (*)
 - user-defined

Resetting the factory default settings

Reset Factory Defaults resets all the MaxiScan 2200 operating parameters to their factory default settings:

- null interface (no interface driver selected—no transmission),
- default symbologies,
- default symbology settings,
- default MaxiScan 2200 operating settings (reading distance, scan rate, beep settings, etc.).

If you scan Reset Factory Defaults, you will have to re-enter the appropriate interface number for your system and any custom settings if applicable. It is often easier to reset individual parameters.

General reset procedure

1. Make a list of your custom MaxiScan 2200 parameter settings if applicable.
2. Scan Reset Factory Defaults.
3. Scan the interface number for your system (see section 6, *Enter the interface number for your system*).
4. Customize the data transmission settings for your interface if required (see section 7, *Set up the data transmission parameters*).
5. Select the symbologies you need and customize the symbology parameter settings if required (see section 8, *Set up the symbology parameters*).
6. Customize the MaxiScan 2200 operating settings if required (see section 9, *Set up the operating parameters*).

Reset Factory Defaults

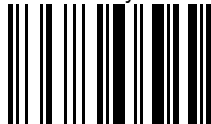

H If you have a problem . . .

This appendix describes things you can check if you have problems with your MaxiScan 2200 during power-up, configuration and normal operation.

If you can not solve the problem yourself, please contact your Intermec representative.

Check the following points

General setup problems

- correct MaxiScan 2200 model for your host system—check the number of orange indicator LED flashes at power-up
- correct cables / external power supply if required
- MaxiScan 2200 connected up correctly
- system switched on—sufficient electrical power
- correct interface number selected for your MaxiScan 2200 model and host system
- correct power-up beep indication—2 beeps
- indicator LED shows green after power-up—orange indicates that no interface number is selected
- End Selection scanned once, twice or three times when required for certain configuration codes

General operating problems

- MaxiScan 2200 in standby mode—present a bar code to activate
- correct symbologies selected for the codes you are trying to read
- all unnecessary symbologies disabled
- symbologies you read are available for your MaxiScan 2200 model
- good reading distance for the reading situation
- good resolution adjustment (video channel) for the type of codes you read
- good scan rate for the type of codes you read
- barcode length compatible with MaxiScan 2200 minimum length / fixed length parameter settings
- barcode quality—damaged or poorly printed codes, "fragile" symbologies
- MaxiScan 2200 configured for check digit and no check digit present in code

Before you contact your Intermec representative . . .

If you do not find a solution after checking the above points, you can try a general reset of the MaxiScan 2200.

1. Switch off the electrical supply to the MaxiScan 2200—switch off the host system or disconnect the MaxiScan 2200.
2. Position the Reset Factory Defaults code (Appendix G) in front of the MaxiScan 2200 and provide electrical power—switch on the host system or reconnect the MaxiScan 2200.
3. Finish the general reset procedure as described in *Resetting the factory default settings* in Appendix G.

If you still have a problem . . .

Contact your Intermec representative with full details of the problem.

Your Intermec representative may ask you to provide the software version number for your MaxiScan 2200. If the MaxiScan 2200 is powered up, try to read the following code to display this information on your host system screen if applicable.

Software Version



I Test codes



I Test codes

Code 39

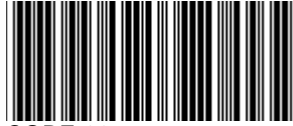

CODE-39

Code 93



CODE-93

Code 128

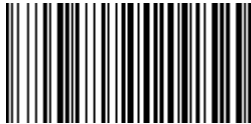

CODE-128

EAN 128

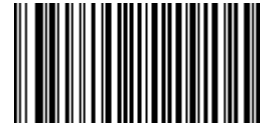

(J)C1)EAN 128

EAN-8



12345670

EAN-13



1234567890128

UPC-A



0 01234 50000 7

UPC-E



0 012345 7

Interleaved 2 of 5

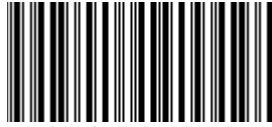

12345678901234

Matrix 2 of 5

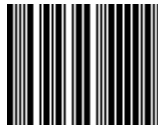

012345

Standard 2 of 5

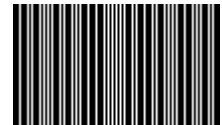

123456

MSI Code



12345666

Plessey Code



80001495050

J Number codes

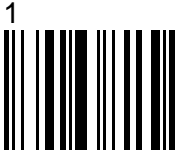

4

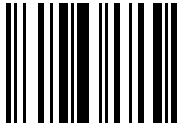

5



6

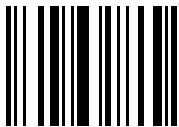

End Selection

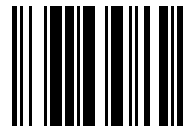

7

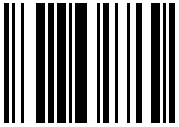

8

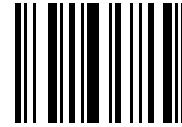

9

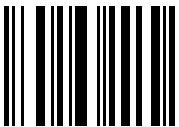

End Selection

