

The Intermec logo is displayed in a bold, blue, sans-serif font. It is positioned to the left of a stylized graphic consisting of several overlapping, light blue circles and lines that resemble an atomic model or a network diagram. A vertical red line extends downwards from the right side of the Intermec logo.

Intermec



Quick Start Guide



**PB40A
Bluetooth
4 inch Belt Printer**

Packing List

Check to ensure that you receive these items:

- Intermec[®] PB40A0B140 Printer (4 inch thermal belt printer with Bluetooth)
- 1 roll of paper (in printer)
- Battery Pack (installed)
- Compliance Insert
- Warranty Card

Common Accessories List

Cable	Part Number
Data Cable (Hirose to RJ-11)	226-469-002
Power Adapters	Part Number
Universal. AC Adapter, 12 volt DC	851-060-104
Cigarette Lighter Adapter, 12 volt	320-066-133
Supplies	Part Number
Replacement Li-Ion 7.2V 1.35 mAh Battery	320-081-122
Thermal paper 130'/roll, 50/case	320-081-011
Cleaning Card	320-066-013

Getting Started

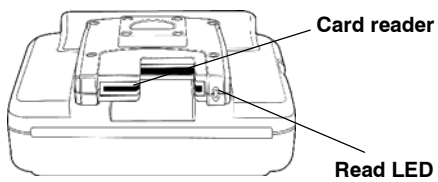
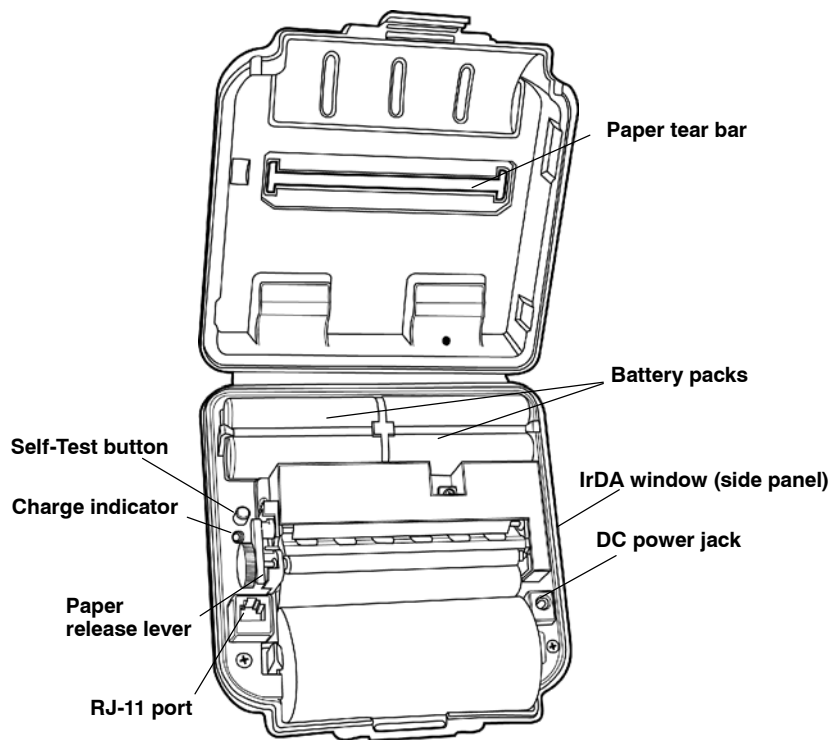

Charging the Lithium Ion Batteries

- The printer battery charges in about 3 hours.

LED Battery Indicators

LED	State of Charge	Action
Solid Red	In Progress	Waiting for green LED
Green	Complete	Remove Charger
Slow Red Flashing	Low Temperature or battery is disconnected	Change environment or connect battery
Fast Red Flashing	High Temperature	Change environment
Slow Red and Orange Flashing	Low Voltage	Wait for solid red
Fast Red and Orange Flashing	High Voltage	Wait for solid red
Slow Orange Flashing	Timeout	Restart charge
Fast Orange Flashing	Internal Error	Remove battery to power down completely and reconnect. Or unplug from charging source, wait 15-20 seconds and reconnect.

Beep Indicator

Number of Beeps	Indicates
One	Printer has come out of sleep mode
Two	Printer is out of paper
Three	Battery is low
One long beep	No program in printer, only boot code

Determining Current Battery Power

To determine the current charge on the battery pack, print out a self test by pressing and holding the red self-test button for four seconds. If the battery is good, you will see the abbreviation for the word “GOOD” next to the Battery voltage print out.

This printer has a built in low battery detector. When the printer's battery voltage is low, the printer beeps three times, indicating a Low Battery Warning. This only happens if the printer is awake.

Paper Loading

Out of Paper

The PB40A Printer sounds two quick beeps when it runs out of paper. If the printer is out of paper, the printer suspends operation until paper is present and the lever is down. The printer continues to communicate with the mobile computer as long as it does not "time out." Once the printer restarts, it finishes the rest of the print job from where it left off.

Removing Paper Core from your PB40A Printer

- 1 Unsnap the latch and lift up the cover.
- 2 Wrap your index finger around the empty paper core and pull up. The paper rod will snap out.
- 3 Remove the empty paper core and discard.

Paper Loading

Standard Paper

If you are using standard paper, you can load the paper automatically or manually. Experiment to find out which method is best for you.

Linered Labels

If you are using linered paper, it is best to use the manual paper loading method.

Automatic Paper Loading

- 1 Press the red self test button to wake the printer.
- 2 With the loose, clean edge of the paper coming from the bottom of the roll, insert the edge of the paper between the roller and the platen.
- 3 Push the button again while the printer is awake causes the mechanism to feed about 1" of paper.
- 4 Insert the paper into the paper well with it resting on the paper rod clips.

Manual Paper Loading

- 1 Lift up the paper release lever. This takes the pressure off the platen. Make sure you have a clean edge on the new paper roll.
- 2 Take the edge of the paper and fold it 45 degrees.
- 3 Insert the tip of the paper between the roller and the platen.
- 4 Push on the paper until the tip is peeking out the other side. (If it seems too tight to insert the tip, lift up the paper release lever and turn the gear to advance the paper).
- 5 Grab the tip and pull it through until the paper is straight.

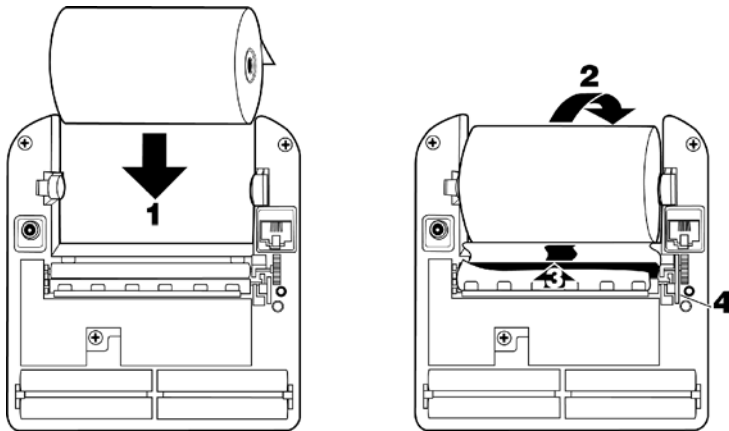

- 6 Push down the paper release lever and insert the paper into the paper well with it resting in the paper rod clips.
- 7 Press the red button while the printer is on and it will feed paper. You will need about 2 inches of paper coming out of the mechanism.
- 8 Lower the cover while placing the extra paper through the tear bar.
- 9 Close Latch Cover and tear off extra paper.

Printer Self Test

Push the red button and hold for about four seconds to print a self test. Below is an explanation of the print-out.

Self Test Print-out Explanation

Test Item	Description
F/W Ver	The internal software version (4.26 for printer, 1.09 or greater for card reader)
Timeout	The seconds between printing and sleep mode.
Baud Rate	The speed at which the printer receives data.
Parity	Odd, Even, or None
Data Bits	Matches with computer sending data to printer.
Handshake	The way the printer handles flow control from host.
Burn Adj	Amount of heat used to print on the thermal paper.
Beeper	May be turned On or Off.
Batt Volt	Current voltage of the battery pack.
Batt Temp	Temperature of the battery.
Flash/RAM	1 Meg or 4 Meg Flash/1 Meg or 4 Meg RAM
Boot Version	Boot sector firmware.
Prnhd Temp	Temperature of print head (between 0 and 50 degrees).
Infrared	Not available at this time.
Device Name	Type of device (i.e. 4t for 4 inch thermal printer)
Device Nickname	Shows user name for printer.
Available Fonts	“LOC” shows whether a font is Resident (R) or Downloaded (D). “CPI” shows characters per inch. “DESCRIPTION” describes the font. “NAMES” give the “Easy Print” name, the Line Printer name, and the hexadecimal equivalent of that name.
Available Graphics	“LOC” shows whether a font is Resident (R) or Downloaded (D). “CPI” shows characters per inch. “DESCRIPTION” describes the graphic. “NAMES” give the “Easy Print” name, the Line Printer name, and the hexadecimal equivalent of that name.

Self Test Print-out Explanation (continued)

Test Item	Description
Available Bar Codes	All supported barcodes are displayed. "DESCRIPTION" describes the graphic. "NAMES" give the "Easy Print" name, the Line Printer name, and the hexadecimal equivalent of that name.
Card Reader Option	Shows the current Card Reader configuration.

Battery Pack Removal



Note: Ensure that you have your ESD wrist strap connected to the ESD static free mat before placing your printer on the mat and begin removing the battery pack.

- 1 Remove the four screws securing the printer mechanism.

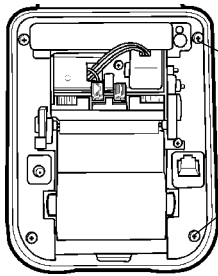

**Screws (4)
(two on each side)**

- 2 Lift the printer mechanism out of the case. One way to do this is to turn the printer case on its side and **gently** tap the bottom of the case to remove the board assembly. Be careful not to pull on the cluster of black wires running from the inside of the printer case to the printer mechanism assembly.

- 3 Set the printer assembly down to view the underside of printer mechanism and battery compartment.

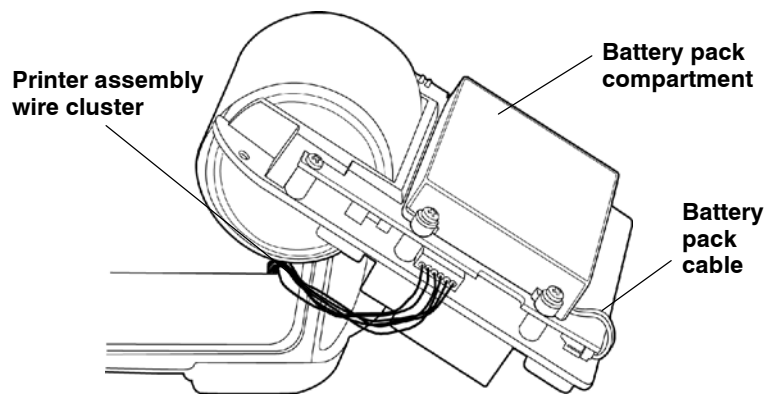

- 4 Remove the four screws securing the battery cover. Avoid contact with the printer control board unless the board is grounded.

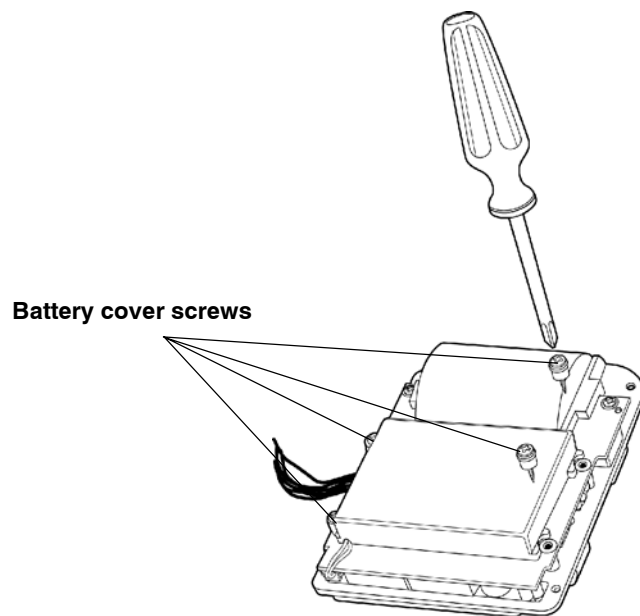

- 5 Gently disconnect the keyed battery pack connector (with the black and red wires) from the board assembly. You may find that you have to wiggle the connector a bit to remove it from the connector.

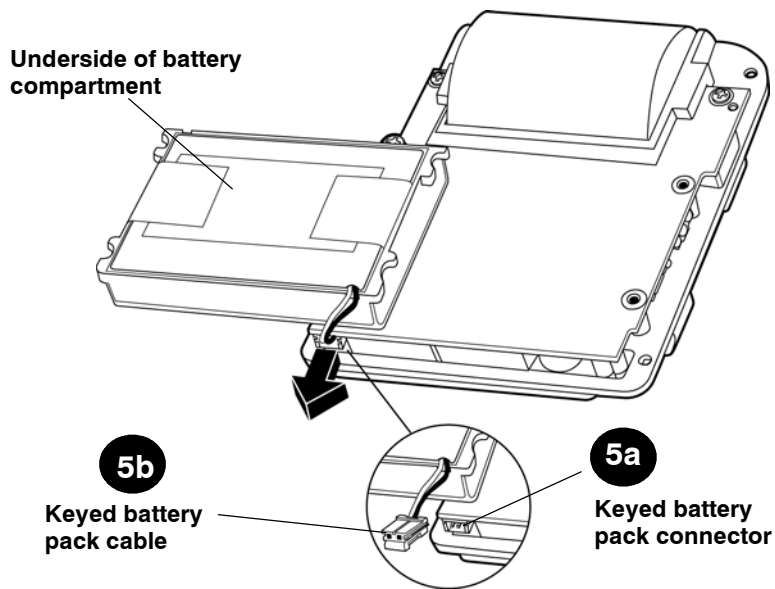

- 6 Once the cover is removed gently tap the cover in your hand or lift up on one of the battery retaining foam strips to separate the battery pack from the cover.
 - 7 Insert the new battery pack into the battery cover.
 - 8 Reinstall the battery cover.
 - 9 Reconnect the keyed battery cable. Routing the battery pack wires is very important.
- The wires must not be pinched or crimped when reinserting the printer mechanism into the printer case.
- 10 Reposition the battery pack assembly on the printer mechanism.
 - 11 Replace the four screws to secure the battery pack cover to the printer mechanism.
- Install the screws enough so they are fully seated but not any further or you will strip the screw holes in the printer case.

- 12 Carefully seat the printer in the case, you do not want to pinch the wires between the printer mechanism and the case.
- 13 Replace the four screws securing the printer mechanism to the printer case.
- 14 Charge the battery 2-3 hours using your AC adapter or cigarette lighter adapter.
- 15 Properly dispose of the used battery pack.

Using Your Printer with Serial Connection

- 1 Attach the Mobile Computer to Printer cable.

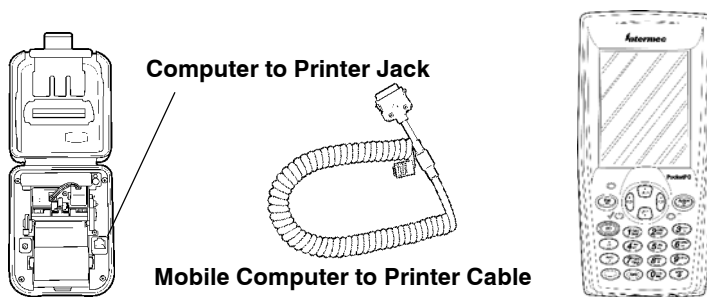

- 2 As you use the printer the power comes from the battery in the printer. When the printer battery runs down the printer will not operate until the battery is recharged.

PB40A Printer using Wireless Printing

IrDA/Wireless Mode

Your printer comes to you as an IrDA mode printer. To switch the mode to Wireless Printing it is necessary to toggle the mode via the self-test function of the printer.

Performing the self-test indicates the current mode of the printer. The mode displays on the ticket and an audible indication sounds. Each time the self-test function is performed the mode will toggle between wireless printing and IrDA modes.

Printer Preparation

- 1 Prepare the PB40A by holding down the red button for about two seconds until you hear a short beep. This means the printer is ready to go and will be discoverable.
 - Any time you press and hold the button until it beeps, you will dump any active wireless printing sessions.
- 2 You are ready to print wireless transactions.

Printer Self-Test

- 1 Press the Paper Advance (red) button for at least five seconds to run a Self-Test.
 - This means you will be holding it long enough to hear the *beep* and complete a *paper advance*.
 - The self-test indicates the current state of your printer.
 - Verify the current mode by reading the Power status line from the printout.
 - When your printer is turned off, the radio is undiscoverable and unconnectable.



When shipping your printer via air freight, turn the wireless printing mode off and set to IrDA so that the radio is not enabled.

Why Printer Beeps Every 5 Minutes When Unconnected

As part of the implementation of the serial port service, this service refreshes itself every five minutes. That refresh sends a message to the printer, which then wakes up and causes the beep while resynchronizing with the serial port service. The printer then goes back to sleep based on its timeout. The beep can be turned off within the 'printer configuration utility'.

700 Mobile Computer Preparation

- 1 On your mobile computer, tap the **Bluetooth™** icon located in the System tray on the **Today** screen.
- 2 Select **Advanced Features>Bluetooth Devices**.
- 3 From the **Tools** menu, select **Device Discovery**. You are presented with a couple of screens detailing the device discovery process.
- 4 You are now presented with a screen allowing you to modify the selection parameters. The default should work for your needs.

5 Click **Next** to proceed. A search for Bluetooth devices is performed followed by a look-up of discovered device names. The progress bars indicate the inquiry status.

6 A list of discovered devices displays.

If your remote wireless printer is discovered and presented in the list, select the **appropriate check box** and click **Next**.

If your remote device is not displayed, ensure that the device and its radio are switched ON. Click **Next**, then select **Finish**.

7 A progress bar appears indicating Service Directory is being performed.

If the discovery is successful a screen with *Successful discovery* displays. Click **Finish**. The remote device icon appears in the Bluetooth Devices Folder. Verify that this device was discovered by looking at the properties (**Device>Properties**).

If the Services tab lists *Portable Printer*, the service was discovered correctly.

If it doesn't, select the **Update** button on the *Services* tab to try to rediscover the services available (sometimes it will take a couple tries to correctly discover the services).

8 Click **Next** twice, all Wireless Printing devices within range will be discovered and displayed. You may have to repeat this step from time-to-time.

9 The **Bluetooth Serial Port** service is necessary for the virtual COM port to work. Choose COM6 in your application to use the Wireless Printing device you selected. Verify that this service was discovered by looking at the properties for this printer (**Device>Properties**).

10 Verify that your Wireless Printing device is set as your "favorite" device. In the **Bluetooth Devices Folder**, select **Tools>My Favorite**. In the **Favorites** screen, ensure your printer shows as **My Favorite Device**.

*Bluetooth is a trademark of Bluetooth SIG, Inc., U.S.A.

Maintenance and Troubleshooting

Cleaning the Interior

Dirt, adhesive and residue collect on the print head of the printer and need to be removed. Clean your printer once a month if you use it frequently, or once every three months if used infrequently.

Cleaning the Exterior

When the outside of your portable printer needs cleaning, use a soft cloth and mild cleanser if necessary. Do not use abrasive cleanser, chemicals or scrubbing pads, as your printer's finish could become marked.

Troubleshooting

Paper Loading Problems

If the paper feed mechanism does not feed correctly on the first part of a new paper roll, remove two to three feet of paper from the outside of the roll. The length of paper rolls can vary by as much as five feet, making the roll too thick for the printer to accommodate.

If the printer is out of paper (or the paper release lever is in the up position) this condition interrupts a batch of receipts, and the printer suspends operation until the condition is fixed. The printer continues to communicate with the mobile computer as long as it does not "time out."

Once the printer is operational, the suspended print batch (if any) continues to print, ensuring that all receipts are properly printed.

Not Printing

- 1 Print a self test. If the self test will not print, check battery voltage by plugging the printer into a wall outlet using the AC adapter. Repeat the self test, and check the Battery Voltage print out. Charge battery if necessary or replace.



Note: If the battery is depleted, it may take 5-10 minutes of charging before the printer can print a self test.

- 2 Make sure the paper is properly installed (with lever closed).
- 3 Turn the print head knob to ensure that paper is not jammed.

- 4 Check cable connections. Make sure the modular connector is inserted and clipped in.
- 5 Check to see if your cable has been damaged by excessive pulling. A cable may also be damaged if it is bent at sharp angles.
- 6 Use only the recommended battery pack for the printer.
- 7 Printer will not print on wrong side of paper. Re-load if necessary.

Print Roller Appears Dirty

Clean Your Printer.

Lined Labels

Lined label printing can cause the print head to become sticky.

Print is Too Light

If you are not getting satisfactory darkness, connect your printer to the personal computer containing your Configuration Program and click on the Paper Options button. Adjust the Darkness setting to a higher percentage until the print is dark and crisp. Refer to the *Intermec Portable Printers Technical Reference Manual* (p/n: 978-018-001) *Section 4* for more details.

Charging Problems

Using an AC Adapter

If the printer does not respond when it is connected to an AC adapter, there could be a problem with the adapter or with the wall outlet.



Note: If the battery is depleted, it may take 5-10 minutes of charging before the printer can print a self test.

Using a Cigarette Lighter Adapter

If the printer does not respond when it is connected to a cigarette lighter adapter, it is possible that the fuse may be blown. To check, remove the cigarette lighter adapter from all power supplies and unscrew the cover over the pin. Pull out the fuse. If the elements in the fuse appear broken, replace the fuse.

Programming Problems

Refer to the *Intermec Portable Printers Technical Reference Manual* (p/n: 978-018-001) *Section 4* for more details OR call the Intermec Technical Support 1-800-755-5505 for assistance.

Specifications

Printer Specifications

Item	Spec Detail
Dimension	6.81 x 6.56 x 3.34 in. 167 x 172 x 85.5 mm)
Weight	25.2 oz. (714 g)
Print Method	Direct Thermal
Paper Medium	Thermal paper
Paper Width	4.4 inch (112 mm)
Operating Temperature	+32 to +122°F (0 to +50°C)
Interface	RS-232C, Infrared, IrDA, ASK
Characters	Full IBM and international character sets
Protocol	Easy Print Protocol for Bar Codes, Stored Graphics, Rotated Fonts.
Power	900 mAh Li Ion 2 cell pack
Warranty	One year, includes print head. Extended warranty available.

Global Services and Support

To request technical support, on-site repair service, return your equipment for factory repair, arrange to have a site survey or product installation or check on service contract status, you may select one of the options:

Web Support

Visit our web site <http://www.intermec.com> to download many of our current manuals in PDF format, utilize our technical knowledge base '*Knowledge Central*' or to request technical support.

Technical Support

To request technical support on your Intermec product call 1-800-755-5505.

Product Warranty

We warrant that Intermec Technologies Corporation products will be free from defects in manufacturing materials and workmanship for one (1) year from date of shipment. This one year warranty applies to the PB40A Printer only. The warranty on the battery pack is 90 days from date of shipment.

Conditions of warranty

- 1 Purchaser must obtain a Return Authorization (RA) number from the Intermec Service Center (1-800-755-5505) within the warranty period.
- 2 Purchaser will provide a written, detailed description of the defect.
- 3 The product must be promptly returned to the designated Intermec Service Center, freight prepaid by Purchaser.
- 4 Upon examination of the product, Intermec must agree that the defect exists and is covered by this warranty. Warranty repairs will be completed at the Service Center and returned to the Purchaser by prepaid surface freight.

The foregoing is a summary of the standard warranty, which shall be purchaser's sole remedy. Complete warranty details can be found in your purchase agreement or obtained from your local Intermec sales office.

In no event shall Intermec Technologies Corporation nor its suppliers be liable for any special, consequential or incidental damages.



Worldwide Headquarters

6001 36th Avenue West
Everett, Washington 98203
U.S.A.

tel 425.348.2600

fax 425.355.9551

www.intermec.com

© 2003-2006 by Intermec Technologies Corporation. All rights reserved.

PB40A Printer Quick Start Guide



P/N 962-018-025E