

# System Manual

## Intermec RFID

Intermec Technologies Corporation

Corporate Headquarters  
6001 36th Ave.W.  
Everett, WA 98203  
U.S.A.

[www.intermec.com](http://www.intermec.com)

The information contained herein is proprietary and is provided solely for the purpose of allowing customers to operate and service Intermec-manufactured equipment and is not to be released, reproduced, or used for any other purpose without written permission of Intermec.

Information and specifications contained in this document are subject to change without prior notice and do not represent a commitment on the part of Intermec Technologies Corporation.

© 2005 by Intermec Technologies Corporation. All rights reserved.

The word Intermec, the Intermec logo, Norand, ArciTech, Beverage Routebook, CrossBar, dcBrowser, Duratherm, EasyADC, EasyCoder, EasySet, Fingerprint, INCA (under license), i-gistics, Intellitag, Intellitag Gen2, JANUS, LabelShop, MobileLAN, Picolink, Ready-to-Work, RoutePower, Sabre, ScanPlus, ShopScan, Smart Mobile Computing, SmartSystems, TE 2000, Trakker Antares, and Vista Powered are either trademarks or registered trademarks of Intermec Technologies Corporation.

Throughout this manual, trademarked names may be used. Rather than put a trademark (™ or ®) symbol in every occurrence of a trademarked name, we state that we are using the names only in an editorial fashion, and to the benefit of the trademark owner, with no intention of infringement.

There are U.S. and foreign patents pending.

# Contents

Before You Begin . . . . .	vii
Safety Information . . . . .	vii
Global Services and Support . . . . .	vii
Warranty Information . . . . .	vii
Web Support . . . . .	vii
Telephone Support . . . . .	viii
Who Should Read This Manual . . . . .	viii
Related Documents . . . . .	ix

## **1 Learning About RFID Systems . . . . . 1**

What is an RFID System? . . . . .	2
About RFID Standards . . . . .	4
About the RF Spectrum . . . . .	5
About Frequencies and Bandwidth . . . . .	5
Understanding Low Frequency Systems . . . . .	6
Understanding High Frequency Systems . . . . .	7
Understanding UHF Systems . . . . .	7
Understanding Microwave Systems . . . . .	7
About Channel Use . . . . .	8
About Power Levels and Duty Cycle . . . . .	8
About Radio Signals . . . . .	8
Understanding the Types of Radio Signals Used in RFID Systems . . . . .	8
What Affects the Radio Signal? . . . . .	10
Overall Signal Strength . . . . .	10
Electrical Noise on the Signal . . . . .	11
About Radio Waves . . . . .	11
Understanding RF Reflection . . . . .	12
Understanding RF Refraction . . . . .	12
Understanding RF Diffraction . . . . .	12
How Multipath Affects the Reading Range . . . . .	12
Using Multipath to Extend the Reading Range . . . . .	13
Avoiding Multipath Null Regions in the Reading Range . . . . .	14
What Affects RFID System Performance? . . . . .	15
Reading Range . . . . .	15
Reading Speed . . . . .	16
Tag Orientation and Placement . . . . .	17
Electrical Noise and Interference . . . . .	17
Tag Life . . . . .	17
Reading Error Rate . . . . .	18
Environmental Capabilities . . . . .	18
Other Considerations . . . . .	18
What Are Methods for Controlling RFID System Performance? . . . . .	19

About Intermec RFID Systems . . . . .	19
Operational Characteristics. . . . .	19
Frequency and Power . . . . .	20
Radio Signals . . . . .	20
Reading Range . . . . .	20
Environmental Capabilities. . . . .	20
<b>2 Learning About RFID Tags . . . . .</b>	<b>21</b>
Understanding RFID Tags. . . . .	22
Read-Only Tags . . . . .	23
WORM (Write-Once/Read-Many) Tags . . . . .	23
Read/Write Tags . . . . .	23
Understanding Tag Technologies . . . . .	23
About Active Tags. . . . .	24
About Active Backscatter Tags . . . . .	24
About Modulated Backscatter Tags. . . . .	25
Inductively-Coupled Tags . . . . .	25
Capacitively-Coupled Tags . . . . .	25
More About Modulated Backscatter Tag Technology . . . . .	26
How Tags Affect the Reading Range . . . . .	27
Tag Power Source . . . . .	27
Tag Orientation and Placement . . . . .	28
Tag Speed . . . . .	30
Tag Mounting Surface . . . . .	30
Tag Sensitivity . . . . .	30
Tag Reflectivity. . . . .	31
How to Choose the Right Tag . . . . .	31
Frequencies and Bandwidth . . . . .	31
Tag Type. . . . .	31
Reading Range Performance. . . . .	32
Form Factor . . . . .	32
Environment . . . . .	32
RFID Standards Compliance . . . . .	32
<b>3 Learning About RFID Readers . . . . .</b>	<b>33</b>
Understanding RFID Readers . . . . .	34
How Readers Affect RFID System Performance. . . . .	35
Reader Sensitivity . . . . .	35
Electrical Noise and Interference. . . . .	36
Sources That Produce Electrical Noise in the RF Field . . . . .	36
Other Sources of Electrical Noise . . . . .	36
Solving Electrical Noise and Interference Problems . . . . .	36
How to Choose the Right Reader . . . . .	37
Application Type . . . . .	37
Frequencies and Bandwidth . . . . .	38

Understanding Scanners and Smart Readers . . . . .	38
About Simple Scanners . . . . .	38
About Smart Readers. . . . .	38
<b>4 Learning About RFID Antennas . . . . .</b>	<b>39</b>
Understanding RFID Antennas . . . . .	40
How the Antennas Affect the Reading Range. . . . .	40
Understanding Antenna Radiation Patterns . . . . .	41
Understanding the Antenna Radiation Pattern Graphs . . . . .	41
Lobes and Nulls in the Antenna Radiation Patterns . . . . .	43
About Attenuation . . . . .	44
Measuring the Antenna’s Radiation Region. . . . .	45
How to Choose the Right Antennas. . . . .	45
<b>5 Some Guidelines for Designing and Installing Your RFID System . . . . .</b>	<b>47</b>
Guidelines for Designing Your RFID System. . . . .	48
How to Reduce Electrical Noise and Interference - General . . . . .	48
How to Reduce Electrical Noise and Interference - Specific Interference Types. . . . .	49
Guidelines for Installing Your RFID System . . . . .	50
Grounding Guidelines . . . . .	50
Shielding Guidelines. . . . .	51
<b>A Other Helpful Information . . . . .</b>	<b>53</b>
Calculations. . . . .	54
Tag Formulas . . . . .	54
Battery-Powered Tags . . . . .	54
Modulated Backscatter Tags . . . . .	55
Antenna Formulas . . . . .	55
Relationship Between Field Strength and Power Density. . . . .	55
Converting Field Strength to Decibels (dB). . . . .	56
Converting Power Density to Decibels (dB) . . . . .	56
How Readers Decode the Radio Signal . . . . .	57
<b>  Index . . . . .</b>	<b>59</b>

## **Contents**

## Before You Begin

This section provides you with safety information, technical support information, and sources for additional product information.

### Safety Information

Your safety is extremely important. Read and follow all warnings and cautions in this document before handling and operating Intermec equipment. You can be seriously injured, and equipment and data can be damaged if you do not follow the safety warnings and cautions.

This section explains how to identify and understand warnings, cautions, and notes that are in this document.



**A warning alerts you of an operating procedure, practice, condition, or statement that must be strictly observed to avoid death or serious injury to the persons working on the equipment.**



**A caution alerts you to an operating procedure, practice, condition, or statement that must be strictly observed to prevent equipment damage or destruction, or corruption or loss of data.**



**Note:** Notes either provide extra information about a topic or contain special instructions for handling a particular condition or set of circumstances.

### Global Services and Support

#### Warranty Information

To understand the warranty for your Intermec product, visit the Intermec web site at [www.intermec.com](http://www.intermec.com) and click **Service & Support**. The Intermec Global Sales & Service page appears. From the Service & Support menu, move your pointer over **Support**, and then click **Warranty**.

#### Web Support

Visit the Intermec web site at [www.intermec.com](http://www.intermec.com) to download our current manuals (in PDF). To order printed versions of the Intermec manuals, contact your local Intermec representative or distributor.

Visit the Intermec technical knowledge base (Knowledge Central) at [intermec.custhelp.com](http://intermec.custhelp.com) to review technical information or to request technical support for your Intermec product.

## **Telephone Support**

These services are available from Intermec Technologies Corporation.

<b>Services</b>	<b>Description</b>	<b>In the USA and Canada call 1-800-755-5505 and choose this option</b>
Order Intermec products	<ul style="list-style-type: none"><li>• Place an order.</li><li>• Ask about an existing order.</li></ul>	1 and then choose 2
Order Intermec media	Order printer labels and ribbons.	1 and then choose 1
Order spare parts	Order spare parts.	1 or 2 and then choose 4
Technical Support	Talk to technical support about your Intermec product.	2 and then choose 2
Service	<ul style="list-style-type: none"><li>• Get a return authorization number for authorized service center repair.</li><li>• Request an on-site repair technician.</li></ul>	2 and then choose 1
Service contracts	<ul style="list-style-type: none"><li>• Ask about an existing contract.</li><li>• Renew a contract.</li><li>• Inquire about repair billing or other service invoicing questions.</li></ul>	1 or 2 and then choose 3

Outside the U.S.A. and Canada, contact your local Intermec representative. To search for your local representative, from the Intermec web site, click **Contact**.

## **Who Should Read This Manual**

This system manual is written for anyone who is interested in installing, integrating, configuring, and maintaining an RFID system. This manual presents many key concepts that you need to understand RFID systems and introduces Intermec RFID systems and components.

It provides a general overview of RFID systems and components as well as general guidelines on how to design and implement an RFID system.

Before you work with RFID technology, you should be familiar with your network and general networking terms, such as IP address.

## **Related Documents**

The Intermec web site at [www.intermec.com](http://www.intermec.com) contains our documents (as PDF files) that you can download for free.

### **To download documents**

- 1** Visit the Intermec web site at [www.intermec.com](http://www.intermec.com).
- 2** Click **Service & Support > Manuals**.
- 3** In the **Select a Product** field, choose the product whose documentation you want to download.

To order printed versions of the Intermec manuals, contact your local Intermec representative or distributor.





# 1 Learning About RFID Systems

This chapter provides an overview of radio frequency identification (RFID) systems and a brief discussion of techniques you can use when designing your RFID system. This chapter contains information on:

- What is an RFID system?
- About RFID standards
- About the RF spectrum
- About radio signals
- About radio waves
- What affects RFID system performance?
- What are methods for controlling RFID system performance?
- About Intermec RFID systems

## What is an RFID System?

For years, visual scanning systems, such as bar code systems, have helped manufacturers and retailers keep track of inventory.



*In order to keep up with inventories, companies must scan each bar code on every pallet or product box.*

Radio frequency identification (RFID) systems evolved as a way to provide all the benefits of visual scanning systems, while overcoming many of their limitations. Radio frequency (RF) describes electromagnetic waves in the 10 kHz to 10 GHz range. Electronic identification (ID) systems transfer data messages from an object to be identified to a data management system. RFID systems use radio frequency to transfer data between an item being tracked and a reader/writer. It is a fast, automatic identification technology.



*An RFID reader can read the RFID tags in/on the box without needing to be in the line of sight of the tags.*

You can see the simplest RFID system being used today in many retail stores. RFID tags are often attached to merchandise. If a tag is not disabled or removed from the merchandise before you leave the store, it passes through the RFID reader at the door and sets off an alarm.

In general, RFID systems consist of these components:

- Tags
- Readers
- Antennas
- Host system

RFID systems may also include a printer that can print bar code labels and write to tag inserts that are adhered under the bar code label. The next two illustrations show examples of generic RFID systems.

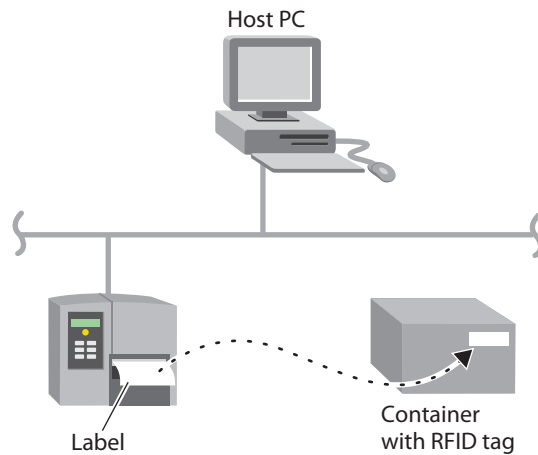

**RFID System Network Diagram - Part 1:** This illustration shows a simple RFID system. The printer prints and writes to labels that contain tag inserts. These labels are attached to a container.

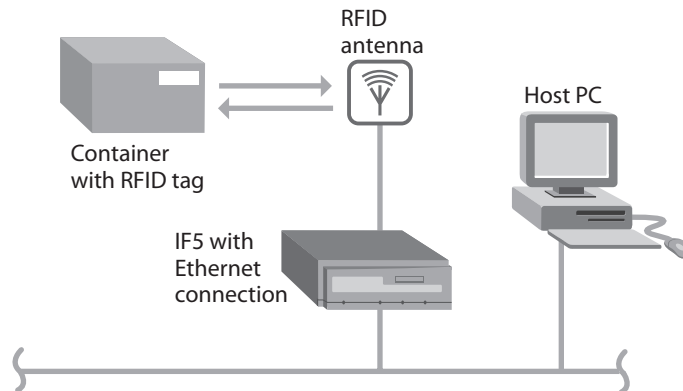

**RFID System Network Diagram - Part 2:** This illustration shows a simple RFID system. A reader reads and writes to the tag on the container and then sends information to an application on a host PC.

A reader is a radio-enabled device that communicates with a tag and with the host system. In order to communicate with each other, the reader and the tag must be set to the same frequency and the tag must be within the reader's reading range. Note that the reader can read information on a tag without the tag having to be in its line of sight or in a particular orientation.

Various tags and antennas are available for use in different applications and in different environments. The tag is simply an extension of the bar code label. It has an embedded single-chip processor and antenna that are mounted on an insert and then encapsulated with appropriate material for its application. A tag has more intelligence than a bar code label. Data can be added to the tag or the existing tag data can be modified. If multiple tags are present in one reading range, the RFID system can be made more efficient by using anti-collision algorithms, which determine the order of response so that each tag is read once and only once.

Overall, RFID technology is a flexible technology that is convenient, easy-to-use, and well-suited for automatic identification operation. It provides security and product authentication because the tags can be applied discreetly and they are extremely difficult to counterfeit. In summary, the benefits of implementing an RFID system are that RFID technology:

- enables labels to carry much more information than standard bar code labels.
- allows existing tag data to be modified or data to be added to existing tag data.
- allows readers to read tag data without tags needing to be in the line of sight of the readers.
- allows multiple tags to be read simultaneously.
- provides more security for data contained in tags than on bar code labels.
- improves speed and efficiency.
- eliminates human error from keying in or manually updating data.
- increases information availability and location.

## **About RFID Standards**

RFID technology standards are being worked on by two major organizations: ISO (International Organization for Standardization) and EPCglobal. There are four different types of standards:

- Air interface protocols, which describe the way readers and tags communicate with each other.
- Data content, which describe how the data is organized.

- Conformance, which contain tests that ensure that RFID equipment meets the standards.
- Applications, which explain how applications are used in an RFID system.

ISO has created many standards for RFID technology that deal with both the air interface protocol and the applications for RFID. The air interface protocol standard that describes how readers communicate with ultra-high frequency (UHF) RFID tags is called ISO 18000-6. There are two versions of 18000-6: 18000-6A and 18000-6B.

EPCglobal created the electronic product code (EPC) and they are responsible for its technology. EPCglobal is creating standards that govern how EPC data is shared among companies and other organizations. Thus, they have written air interface protocol standards that describe how readers communicate with EPC tags. The first standards were classified as EPCglobal Gen 1 and they addressed class 0 and class 1 tags. Now, EPCglobal has developed a second-generation air interface protocol called EPCglobal Gen 2, which is designed to communicate with tags that are a higher class and that will work internationally.

Intermec makes RFID equipment that supports both ISO 18000-6B and EPCglobal Gen 2. Any equipment that supports either of the standards are technically interoperable. EPCglobal Gen 2 tags include an application family identifier (AFI). Intermec's RFID equipment supports many other international RFID technology standards. If you have any questions, contact your local Intermec representative.

## **About the RF Spectrum**

The RF spectrum is regulated by government regulatory agencies, such as the FCC, who establish guidelines for its use. Depending on the region and country where you are installing your RFID system, you must follow that agencies' guidelines. Typically, the guidelines specify how you can use these features:

- Frequency and bandwidth size
- Channel use (primary or secondary)
- Power level (in milliwatts or watts)
- Duty cycle (percent of time allowed to output power)

## **About Frequencies and Bandwidth**

All RFID systems must operate within national and international laws and regulatory guidelines with respect to frequency and bandwidth use. Depending on the country, several frequency bands may be available. However, operating outside the more common bands has disadvantages.

RFID systems can be classified according to the frequency band in which they operate:

- low frequency (10 to 500 kHz), near-field system using modulated backscatter, inductively-coupled tags.
- high frequency (10 to 15 MHz), near-field system using modulated backscatter, inductively-coupled tags.
- ultra-high frequency (860-960 MHz), far-field system using modulated backscatter, capacitively-coupled tags or active tags.
- microwave frequency (2.4-5.0 GHz), far-field system using modulated backscatter, capacitively-coupled tags or active tags.



**Note:** Near-field systems are systems that have less than one wavelength from the antennas to the readers/tags. Most near-field system performances are controlled by inductive coupling with the antenna. Most far-field system performances are controlled by radiated emissions.



**Note:** An active tag uses an internal battery to send radio signals. A modulated backscatter (passive) tag reflects the reader's energy to send radio signals. The tag's circuits can be inductively-coupled (use magnetic energy) or capacitively-coupled (use electric energy). For more information, see Chapter 2, "Learning About RFID Tags."

Each frequency band has advantages and disadvantages that you need to understand when designing your RFID system. Depending on which frequency band your RFID system uses, certain characteristics of the RFID system can be affected, such as reading range.

**For low and high frequency systems:**

- Higher frequency = shorter radio wavelength = longer reading range

**For ultra-high frequency and microwave systems:**

- Higher frequency = shorter radio wavelength = shorter reading range

The next sections explain the different frequency systems in more detail.

**Understanding Low Frequency Systems**

Low frequency systems usually operate in the 125 to 135 kHz range. They use modulated backscatter, inductively-coupled tags. In this frequency range, you get small amounts of data at slow speeds, short reading ranges, and large tags due to large looping antennas. Typically, the reading range is half the longest dimension of the antenna loop. However, the tags are inexpensive.

This frequency range is relatively free from regulatory limitations. Although it does not penetrate metals very well, it does penetrate other materials, such as tissue (people, animals, etc.), wood, and water. It is often used for animal identification and access control.

Currently, Intermec does not produce equipment for low frequency systems.

### **Understanding High Frequency Systems**

High frequency systems usually operate at 13.56 MHz. They also use modulated backscatter, inductively-coupled tags. Since these tags have a simpler antenna design, they are even more inexpensive than the tags used in low frequency systems.

Like the low frequency systems, this system is good at reading small amounts of data at slow speeds. However, it transmits data at slightly higher speeds than low frequency systems and has a slightly larger reading range (0.7 m or 2.3 ft). This frequency band is a government-regulated frequency. Like the low frequency systems, it does not penetrate metals very well, but it does penetrate tissue and water. It is typically used for access control, inventory control, and smart cards.

Intermec has produced limited equipment for high frequency systems.

### **Understanding UHF Systems**

Ultra-high frequency (UHF) systems usually operate in the 865 to 928 MHz range. They use modulated backscatter, capacitively-coupled tags or active tags and have antennas that allow them to have reading ranges much larger than the antenna dimensions. Because these tags have smaller antennas than high frequency systems, they are smaller than the tags used in high frequency systems.

UHF systems have a reading range that is from a few to many wavelengths long. They are good at reading large amounts of data at high speeds. The 865 to 928 MHz range is the best range for distances between 1 m (3.3 ft) and 10 m (33 ft). UHF frequency ranges are government-regulated. They are not very effective frequencies in environments that have a lot of tissue or water. However, they are effective around metals. This system is best for supply chain management applications.

Intermec produces equipment for UHF systems. This worldwide frequency range supports both ISO and EPCglobal standards.

### **Understanding Microwave Systems**

Microwave systems usually operate at the 2.4 GHz range. They use modulated backscatter, capacitively-coupled tags or active tags. Because these tags have the smallest antennas, they are the smallest tags.

Microwave systems have a longer reading range than low or high frequency systems, but a much shorter range than UHF systems. 2.4 GHz has a reading range of about 1 m (3.28 ft). Microwave systems are government-regulated and are more susceptible to noise (such as noise generated by wireless LANs and microwave ovens) than UHF systems. However, if you are not concerned about reading range, this frequency has a lot of bandwidth available to it and has more channels to hop between.

Intermec has produced limited equipment for microwave systems.

## About Channel Use

All RFID systems must operate within national and international laws and regulatory guidelines with respect to channel use. Depending on the country, the operating frequency for RFID may be a primary or secondary service. Primary services let you broadcast radio waves however, secondary service or out-of-channel emissions must be kept low to provide efficient use of the overall band. Primary services must not jam or decrease performance for any other devices that use frequencies outside the allowed RFID frequency bands.

If the operating frequency is a primary service, it can claim interference from a secondary service. However, a secondary service cannot claim interference from a primary service.

## About Power Levels and Duty Cycle

All RFID systems must operate within national and international laws and regulatory guidelines with respect to power levels and duty cycle. Power levels are defined as the maximum wattage (W) allowed at EIRP (Effective Isotropic Radiated Power). EIRP is the apparent power transmitted towards the antenna, if it is assumed that the signal is radiated equally in all directions. In the U.S.A., RFID equipment can only radiate a maximum power of 4 W. In Europe (according to ETSI 300 220), the maximum power output is 0.5 W or 2 W, depending on the frequency.

Duty cycle is defined as the percent of time the RFID equipment is outputting power. For example, in Europe at 869 MHz, each reader can only radiate a maximum of 0.5 W at a 10% duty cycle per hour. That is, the reader can only transmit for six minutes out of every hour.

## About Radio Signals

In RFID systems, the readers and active tags generate the radio signal and broadcast them into the environment through antennas.

## Understanding the Types of Radio Signals Used in RFID Systems

Radio signals are sent out as waves. All waves can be described in reference to their amplitude or strength. In RFID systems, there are three main types of radio signals that are used:

- Continuous-wave
- Pulsed
- Swept frequency

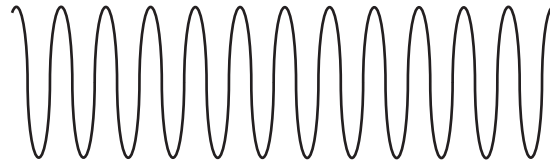

Continuous-Wave

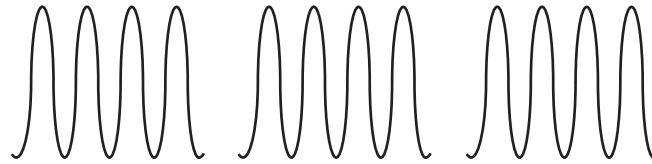

Pulsed

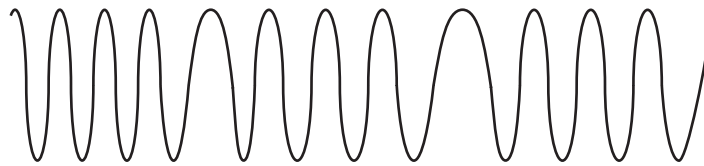

Swept Frequency

*This illustration shows the three types of radio signals that are used in RFID systems.*

When you design your RFID system, you need to consider what type of radio signals you will use. The reader-to-tag signal can be the same as or it can be different from the tag-to-reader signal.

### Reader/Tag Radio Signals Used in RFID Systems

Reader-to-Tag Signal	Tag-to-Reader Signal	Description
Frequency $f$ (continuous-wave)	Frequency $f$ (continuous-wave)	This system, called a homodyne system, uses a single frequency for both the outgoing signal from the reader and the return signal from the tag. It uses electrical and magnetic fields to distinguish the transmitted signal from the return signal.  Intermec RFID systems use this type of radio signals at each frequency during the hop period.
Frequency $f$ (continuous-wave)	Frequency $2f$ (continuous-wave)	This system transmits a signal to the tag at a single frequency and retrieves the tag's code on that frequency's second harmonic.
Frequency $f$ (continuous-wave)	Different frequency $F$ (continuous-wave)	In this system, the tag responds on a frequency ( $F$ ) not related to the reader frequency ( $f$ ).
Swept Frequency	Discrete Frequency	The swept frequency systems broadcast (scan) across a range of frequencies. Tags respond at particular frequencies determined (programmed) by the desired identification data.

**Reader/Tag Radio Signals Used in RFID Systems (continued)**

Reader-to-Tag Signal	Tag-to-Reader Signal	Description
Swept Frequency	Delayed Discrete Frequencies	
Pulsed	Delayed Pulses	Pulses transmit a pulse-modulated carrier signal. The tag retransmits the pulses from the carrier, delayed in a manner which reveals the tag's message.

**What Affects the Radio Signal?**

The most significant factors that influence the radio signal are overall signal strength and noise on the signal.

**Overall Signal Strength**

The overall signal strength is influenced by three factors: power density, field strength, and antenna gain. Power density is the amount of energy flowing from an antenna through a unit area that is normal to the direction of propagation in a unit time. It is measured in watts per square meter. Field strength is the intensity of a radio signal measured at a certain distance from the transmitting antenna. Field strength is usually expressed in volts per meter. Antenna gain is the ratio of the signal, usually expressed in dB, received or transmitted by an antenna as compared to an isotropic antenna. You can only achieve antenna gain by making an antenna directional, that is, with better performance in one direction than in others.

As a radio signal propagates out from the source (antenna), the total RF energy radiated from the source (antenna gain) remains the same, but the overall signal strength decreases as the distance from the source increases.

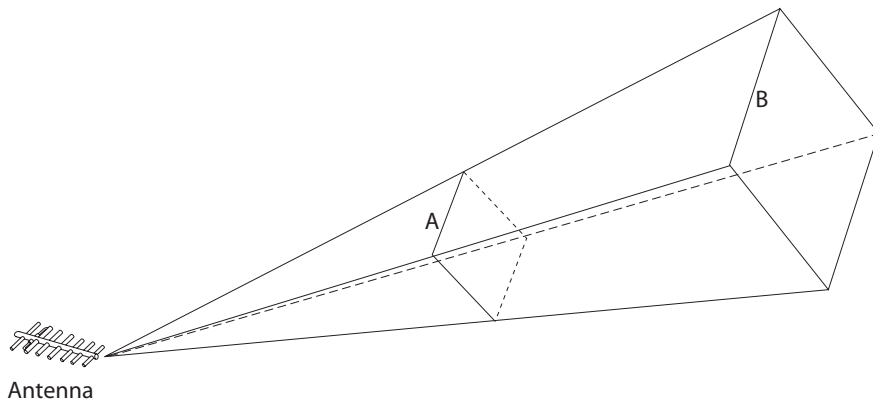

*In this illustration, the antenna pattern is shown as a rectangular area. As a tag moves from point A to point B, the antenna gain remains the same, but the radio signals have to travel farther. Therefore, the distance the radio signals have to travel is directly proportional to the decrease in field strength. However, the square area of the power density at point A is significantly smaller than the area of the power density at point B (inverse square law).*

In other words, as the radio signal (tag) moves away from the source (antenna), the antenna gain remains the same, but its field strength and power density decrease.

Doubling the antenna gain will double the field strength. The field strength decreases as the inverse of the distance from the antenna. For example, the field strength at 3 m (10 ft) from the antenna is twice the strength at 6 m (20 ft) from the antenna.

The power density of the radio signal follows the inverse square law, which means it decreases as the inverse square of the distance from the antenna. For example, if the power density at 3 m (10 ft) from the antenna is 1 watt per square meter, the power density at 6 m (20 ft) from the antenna is 0.25 watts per square meter.

## **Electrical Noise on the Signal**

The electrical noise on the radio signal is influenced by:

- noise within the reader.
- noise within the tags.
- other RF transmitters.
- other sources that produce low frequency noise (keys jingling).
- fluorescent lighting.
- interaction with nearby objects.

## **About Radio Waves**

Since radio signals (RF energy) are sent out as waves, an RFID system is influenced by many fundamental properties of radio waves. In many ways, radio waves behave like light waves or water waves. Radio waves can:

- travel in straight lines.
- undergo reflections.
- be refracted (the bending of a wave as it passes in or out of a medium, like light passing through water).
- bend around certain objects (diffraction).

When radio waves are normal, such as those broadcast from an RFID system antenna, they travel in a straight line. When a radio wave is added to or subtracted from reflected or refracted radio waves from the same source, it causes an effect called “multipath.” Multipath is the existence of multiple routes for a single beam of RF energy. How the multipath is formed is determined by the location of the peaks and valleys of the radio waves when they converge.

## Understanding RF Reflection

Radio waves are reflected from metallic surfaces as well as dielectric (non-conducting) surfaces. RF reflectors can allow tags outside the antenna's line of sight to be read and can cause multipath effects.

Metallic surfaces are the most common and most effective RF reflectors. However to a lesser extent, radio waves are also reflected by dielectric materials, such as dirt, wood, ice, asphalt, and cured concrete. When dielectric materials in the system environment become wet, they reflect radio waves more effectively, thus behaving more like metallic surfaces. Note that whether coarse or smooth, the surface texture of an RF reflector has negligible effect on its reflectivity.

When designing an RFID system, you must make sure to factor in RF reflectors in the environment. To control RF reflections, use careful antenna placement and aiming and RF power reduction. Where these factors alone cannot adequately control RF reflections, you may need to use other techniques (shielding, absorbing, range sensitivity adjustment, handshake counts, or barriers).

## Understanding RF Refraction

Any material that the radio signal can pass through refracts the signal to some extent. When a radio signal enters a dielectric at an angle, its direction of travel is altered by a small degree. RF refraction rarely affects RFID system performance, except when tags are mounted on or under surfaces where dielectric materials are placed (or may accumulate) over the tag (between tag and system antenna).

## Understanding RF Diffraction

RF diffraction may affect RFID system performance. RF diffraction occurs when radio waves are bent around objects in the environment, allowing them into “shadow” areas normally expected to have little or no signal. Metal poles, corners of buildings, and coin collection boxes in toll plazas often create diffraction.

## How Multipath Affects the Reading Range

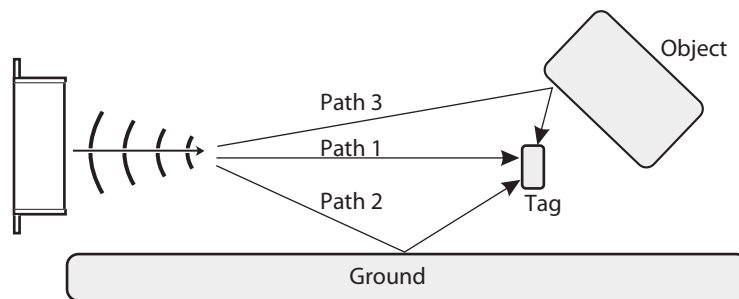

**Multipath:** When two or more favorable radio paths exist between the tag and the antenna.

Multipath occurs when two or more favorable radio paths exist between the tag and the antenna. Multipath signals can add at their intersection, creating an area of field enhancement beyond the normally expected reading range, or they can subtract, creating unexpected null regions within the antenna's reading range.

### Using Multipath to Extend the Reading Range

You can use the constructive interference of multipath signals to create field enhancement, which extends the reading range. Constructive interference describes the combined, positive effect of a main radio signal intersecting in phase with one or more reflected radio signals. Although the reflected radio signals are considered to be interference, the net result is a constructive one.

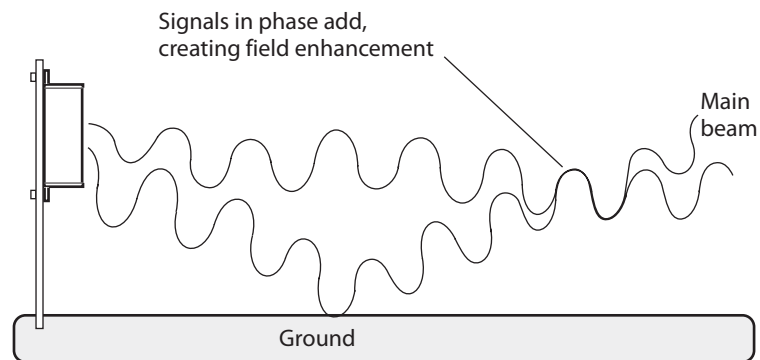

**Using Multipath to Extend the Reading Range:** An antenna sends out a radio signal as a main beam. It also sends out another portion of the radio signal that is just off axis and is reflected by the ground. Since both radio signals' phases are synchronized when they intersect, the combined effect creates an extended reading range.

In this example, an antenna mounted 1.5 m (5 ft) from the ground sends out a main beam that is a direct radio signal that is strong enough to read a tag as far away as 6 m (19.7 ft). The antenna also sends out another portion of the radio signal that is just off axis (maybe at a 2° to 3° declination), which is reflected by the ground, and then intersects the main beam at a point well beyond the optimal reading range.

Under normal circumstances, both radio signals would be too weak to read a tag at this distance. However, because both radio signals' phases are synchronized at the point of their intersection, the combined effect creates an area of extended reading capability. The effect is significant to a distance that is twice the maximum normal reading range, where the enhanced field strength could be twice the field strength of either beam alone. In the case of the above example, the enhanced reading range could extend as far as 12 m (39.3 ft).



**Note:** In an actual multipath environment, the reflected signal can have one more wavelength than the direct beam.

### Avoiding Multipath Null Regions in the Reading Range

Null regions are areas that are within an antenna's normal reading range where tags cannot be read. Null regions are often found near (centimeters to a few meters or inches to a few feet) reflecting objects such as floors, walls, or metal shelving. Farther out, null regions occur in areas where direct and reflected or diffracted beams from the same source merge (multipath) and the signals subtract from each other.

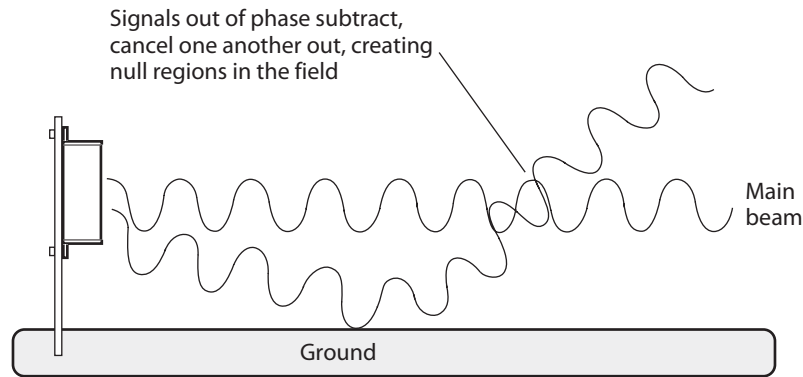

### How Null Regions Affect the Reading Range

Null regions can be as small as a few centimeters (inches) to as large as a meter (3 ft) or more across, and are difficult to predict or locate. You can detect the presence of null regions by comparing the number of tag reads at a given speed (61 m/min or 200 ft/min), with the number of tag reads at twice that speed (122 m/min or 400 ft/min). If the number of tag reads at the higher speed is less than half the number of tag reads at the lower speed, you can suspect the existence of a null region.

It is easiest to locate null regions by carefully mapping the reading range. The impact of null regions on RFID system performance depends on the overall size of the reading range and the speed at which the tag passes through that range.

You can avoid the existence of null regions by using:

- proper antenna placement.
- proper antenna orientation.
- polarization of antenna and tag.
- tag motion.

## What Affects RFID System Performance?

The performance of an RFID system will vary with the principles of the system and the details of its implementation. Since RFID technology is a radio-based technology, its performance is susceptible to interference from other radio transmissions, interference from metals, materials that absorb radio signals, and environmental factors. However, most situations can be handled by using the proper tags, readers, and applications.

In general, the operational characteristics of an RFID system are determined primarily by these factors:

- Reading range, or the maximum distance between the system antenna and tag that will allow a successful read or write.
- Reading speed, or the maximum speed of the tag that will allow a successful read or write.

Factors that influence the reading range and reading speed are the:

- number of characters to be read from the tag.
- coding format of the tag data.
- sensitivity to tag orientation and placement.
- immunity of the system to electrical noise and interference .
- tag life.
- reading error rate.
- environmental capabilities of the tag and reader.

### Reading Range

The reading range is the volume of space surrounding the antenna where a tag can be successfully read. For the successful performance of any RFID system, you must have well-defined reading range (also called a capture window) for all readers and antennas (tag and system). The system hardware configuration and the reader firmware commands function together to define the characteristics of the reading range.

Other primary factors that shape the reading range are:

- tag speed through the reading range.
- tag power source (battery, reader).
- tag sensitivity and tag reflectivity.
- tag orientation vs. antenna orientation (polarization).
- tag mounting surface.
- presence of other tags in the reading range.
- antenna radiation (gain) pattern.
- reader power.

- RF reflectors.
- obstructions.
- other sources of electrical noise and interference.

To control extended reading ranges, you need to consider:

- tag separation.
- tag placement.
- antenna placement.
- antenna orientation.
- control of geometry.
- control of reader power.
- shielding or absorbing materials.
- handshake counts (firmware filters).

## **Reading Speed**

The reading speed is measured by the amount of time it takes the reader to receive a complete code frame (a tag's encoded message) while the tag is within the reading range. Because signal reception does not always start at the beginning of the tag's message, you must design the system to receive slightly more than two full code frames to ensure that it receives the entire message.

Reading speed can be improved by:

- increasing the width of the reading range.
- decreasing the number of characters (length of message) read from the tag.
- decreasing the number of tags to be read simultaneously.
- increasing the clock rate of the tag.
- programming the reader protocol to control the type of tag from which it receives data.

## Tag Orientation and Placement

You must be sensitive to how the tag is oriented and the surface on which the tag is mounted.

Ideally, you should orient the tag so that the polarization of its internal antenna is always aligned favorably with the polarization of the system antenna. If you do not properly align the tag and system antennas, you may only end up with 10% of the overall reading range. For example, a linear polarized tag and a linear polarized system antenna that are not aligned correctly will not have any range. If polarity of the tag is not consistent, you can use non-polarized or circularly polarized tag and system antennas, but they reduce the maximum reading range by 10% or more.

Also, the surface on which the tags are mounted can affect the tag's performance. It may improve performance by directing the reflected signal toward the system antenna or it may decrease performance by reflecting the signal away from the system antenna or by absorbing a portion of the signal.

## Electrical Noise and Interference

RFID systems are affected by electrical noise and interference that may be present in the environment. The equipment must be able to cope with common sources of electrical noise and interference, such as other communication systems and devices, televisions, cellular phones, two-way radios, radar, and other readers and tags.

RFID systems are also affected by noise generated by motors, fans, digital equipment, and automobile ignition systems. Fluorescent lights and neon signs can interfere with the radio signal.

RFID systems that use tags that transmit harmonics of the reader signal often encounter “rusty joint” problems. Anywhere radio currents flow in devices with nonlinear effects (in semiconductor junctions including electronics, and at inadvertent junctions such as rusty joints), harmonics of the reader signal are generated. These harmonics can interfere with the coded harmonic signals generated by the tag and may cause poor performance in these types of systems.

## Tag Life

Modulated backscatter tags last “forever.” That is, they last as long as the life of most normal low-use electrical systems unless they are damaged. Active backscatter (semi-passive) and active tags last until the battery that is used to power them is exhausted from repeated use or loses energy from internal leakage or both.

## Reading Error Rate

In order for reading error rates to be useful, they must be fully described and understood. Reading errors may include:

- good tags that were missed.
- good tags providing bad data.
- “ghost” reads, which occur when a reader says it has read a tag, but the tag is not there.

You should create a summary of the RFID system’s performance, including a report of how many good tags were read. Then, a statistical analysis of these rates may indicate a need for an on-site visit to see what may be wrong. Also, this analysis can be run in a background application that is set to trigger when averages drop below a predetermined level, which may indicate a system fault. You may also want to know when individual tag-reader transactions fail to meet predefined levels, possibly indicating a tag fault.

## Environmental Capabilities

Radio signals can be degraded by obstructions or materials between the tag and antenna. Radio waves penetrate non-conducting materials (such as snow, ice, dirt, wood, paper, plastic, and cured concrete) with only moderate attenuation.

Other, more conductive materials, such as water (especially saltwater), not only attenuate the radio signal, but can also reflect or refract a portion of the radio waves at the surfaces of the material. The amount of refraction produced is related to the dissimilarity in impedances of adjacent materials.

## Other Considerations

Many fundamental properties of radio waves (reflection, refraction, diffraction, multipath) influence the RFID system. Multipath can cause high fields (extended reading range areas) and low fields (null regions) that must be taken into account when you design your system. The combined effects of signal diffraction and multipath reflections can allow tags to be read under seemingly impossible circumstances.

## What Are Methods for Controlling RFID System Performance?

To control RFID system performance, use this list:

### First priority (preferred):

- Appropriate RFID system frequency, bandwidth, and channel use
- Appropriate power levels and duty cycle
- Antenna placement and orientation
- Tag mounting (surface and orientation)

### Second priority:

- ID filters
- Host system logic

### Third priority:

- Range sensitivity adjustment
- Multiple readers

### Fourth priority:

- Screens, absorbing surfaces
- Control of multipath effects

## About Intermec RFID Systems

Intermec makes RFID equipment that supports both ISO 18000-6B and EPCglobal Gen 2. Any equipment that supports either of the standards are technically interoperable. Intermec's RFID equipment supports many other RFID technology standards.

The Intermec RFID system is an ultra-high frequency, primarily far-field system. It uses modulated backscatter, capacitively-coupled, class 2 tags.

## Operational Characteristics

Among the features and advantages inherent in Intermec RFID technology are:

- adaptability to international RFID requirements, follows ISO and EPCglobal standards.
- homodyne (single-frequency) operation.
- tag simplicity (modulated backscatter tags).
- high reading speed.
- high immunity to electrical noise and interference.
- alignment tolerance.

## Frequency and Power

Intermec tags operate within the 860 MHz to 960 MHz UHF band (typically 869, 915, and 950 MHz) with subbands and specific operating rules that are locally defined for worldwide electronic identification.

Power levels used by Intermec RFID systems vary with installation needs and local power restrictions.

## Radio Signals

Depending on the local RF regulations, Intermec RFID technology uses either a homodyne system or a frequency hopping signal. The homodyne system uses a single frequency, continuous-wave signal that is transmitted from the reader to the tag. It receives an amplitude-modulated form of the same signal from the tag. The homodyne system uses electrical and magnetic fields to distinguish the return signal from the transmitted signal.

## Reading Range

Intermec's modulated backscatter tags can be read at distances from a few centimeters (inches) to 6 m (20 ft) or more, from the antenna, and at speeds in excess of 152 m/min (500 ft/min), depending on local RF regulations and the environment.

## Environmental Capabilities

Intermec RFID components are designed to operate optimally even under harsh environmental conditions such as extreme heat or cold. The system is virtually unaffected by factors such as precipitation, vibration, and dirt, encountered in normal operating circumstances.



# 2 Learning About RFID Tags

This chapter explains the type of RFID tags that you may use in your RFID system and how the tag you choose affects the reading range. This chapter covers these topics:

- Understanding RFID tags
- Understanding tag technologies
- How tags affect the reading range
- How to choose the right tag

## Understanding RFID Tags

RFID tags (also called transponders) are attached to objects that you want to track. The tag transfers data to the reader using radio waves that are tuned to the same frequency as the reader and within the reading range of the reader. The tag circuitry consists of a microchip attached to an antenna. This circuitry is adhered to an insert, which is then packaged for the appropriate application.

Tags come in many different form factors for different applications and for different environments. A tag can be mounted inside a carton or it can be embedded in plastic for mounting in a damp environment. A tag may be as small as a grain of rice or as large as a brick. It may be adhered under a label. Some examples of the types of tags are: container tags, windshield sticker tags, tire tag inserts, metal mount tags, and inserts.



**RFID Tags:** These pictures show some examples of stick tags and some labels that have tags adhered under them.

Tag data is typically contained in an electrically-erasable, programmable, read-only memory circuit, or EEPROM. Tags can be programmed by the manufacturer or customer to match information on the object to be tagged, such as part number, serial number, destination, purchase order, SSCC, and so forth.

Besides form factors, tags vary by their performance. They can be read-only, write-once/read-many (WORM), or read/write. Tags also vary by their technologies. They can use active, active backscatter, or modulated backscatter to power their circuitry and communicate with the reader.

## Read-Only Tags

Read-only tags are generally the least expensive. A read-only tag is prenumbered and requires a host database. Once a read-only tag is programmed by the manufacturer, you cannot alter its data.

Currently, Intermec does not provide read-only tags.

## WORM (Write-Once/Read-Many) Tags

WORM tags are a form of read-only tags. A WORM tag is prenumbered and requires a host database. Once a WORM tag is programmed by the manufacturer or by the customer, you cannot alter its data.

Currently, Intermec does not provide WORM tags.

## Read/Write Tags

Read/write tags are much more flexible than read-only tags or WORM tags. A read/write tag generally requires larger chips than the other tags, however it can hold much more information. Each ISO 18000-6B tag contains a unique serial number, but it also may have other information, such as a customer's account number.

You can update or change the information as often as needed. Because the read/write tag becomes a portable database that travels with the product, you can modify its data throughout its journey along the supply chain. Depending on the individual chip capabilities, you can also permanently lock the data on a byte-by-byte basis.

Intermec provides read/write tags.

## Understanding Tag Technologies

There are three different types of RFID tag technologies that you can use: active, active backscatter (semi-passive), modulated backscatter (passive).

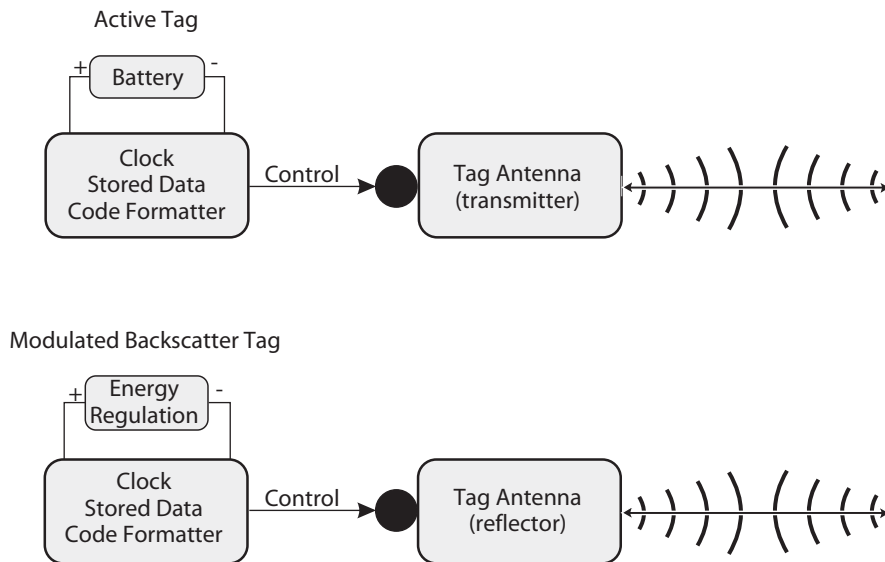

**RFID Tag Block Diagrams:** Active tags are also called battery-powered tags because they are powered by a small lithium battery. Modulated backscatter tags are also called beam-powered tags because they are powered by reflecting the RFID reader's radio signal.

Active and active backscatter tags are most useful for tracking high-value goods that need to be scanned over long ranges. However, they are too expensive to put on low-cost items. Since modulated backscatter tags are the least expensive, they are best for tracking ordinary goods that are scanned over shorter ranges.

## About Active Tags

Active tags are the most expensive because each tag has a small lithium battery that powers its radio, circuitry, and memory. Since the active tag has an on-board power source, it has the longest reading range, which is about 91.4 m (300 ft). This tag is the best selection when your most important consideration is to be able to read tags at the greatest distance.

Active tags have a limited operating life because the battery eventually loses power and replacing the battery is probably more expensive than replacing the tag. Also, active tags can only be used in certain environments because they add to the radio noise background.

Currently, Intermec does not provide active tags.

## About Active Backscatter Tags

Active backscatter tags, also called battery-assisted tags, are less expensive than active tags. The tag has a medium reading range, which is between 3 and 15.2 m (10 to 50 ft). The battery in the tag powers the tag's internal circuitry, but it does not power its radio. The reader (through its antennas) transmits RF energy. When a tag enters the reader's reading range, it reflects the reader-generated RF energy to transfer data.

Like the active tags, active backscatter tags have a limited operating life because they eventually lose power and it is probably not worth the cost to replace the battery. The more the tag is read, the sooner the battery runs out.

Currently, Intermec does not provide active backscatter tags.

## About Modulated Backscatter Tags

Modulated backscatter tags, also called passive tags, are the least expensive, the lightest, and have a virtually unlimited life time. The tag has a shorter reading range than active backscatter—between a few cm (in) to 5.5 m (18 ft). Like active backscatter technology, the reader (through its antennas) transmits RF energy. When a tag enters the reader's reading range, it reflects the reader-generated RF energy, which powers the tag. Since the tag cannot transmit its own signal (since it has no internally-supplied power), it simply reflects part of this RF energy back through its antenna to the reader's receiver. These tags do not contribute to radio noise background.

Modulated backscatter tags require a reader to have much more power than a reader for active tags. They can be inductively-coupled or capacitively-coupled.

### Inductively-Coupled Tags

Inductively-coupled tags (also called radio-wave-coupled tags) are powered by magnetic energy from the reader. That is, a coil in the reader antenna and a coil in the tag antenna form an electromagnetic field. The tag draws power from the magnetic energy in the field and uses it to run its circuitry. Because the tag must be close to the reader, the reading range of inductive tags is very small.

### Capacitively-Coupled Tags

Capacitively-coupled tags (also called propagation-coupled tags) are powered by the electromagnetic energy generated by the reader. The tag gathers the energy from the reader antenna and reflects back an altered signal. Capacitively-coupled tags are less expensive and more flexible than inductively-coupled tags. They also have a longer reading range.

## More About Modulated Backscatter Tag Technology

Intermec provides RFID systems that use modulated backscatter tags. The reader (through its antenna) sends an unmodulated radio signal toward the tag, which acts as a “field disturbance device.” Once the tag is activated, it reflects back to the reader a coded signal that has been varied to be at the same frequency as the signal that was originally transmitted. The coded signal is derived from the energizing signal and carries tag information as a sequentially-coded binary message.

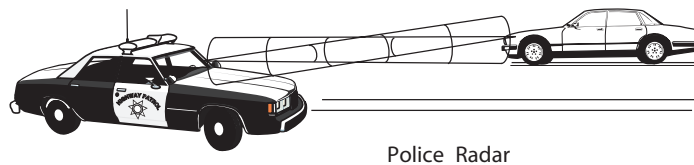
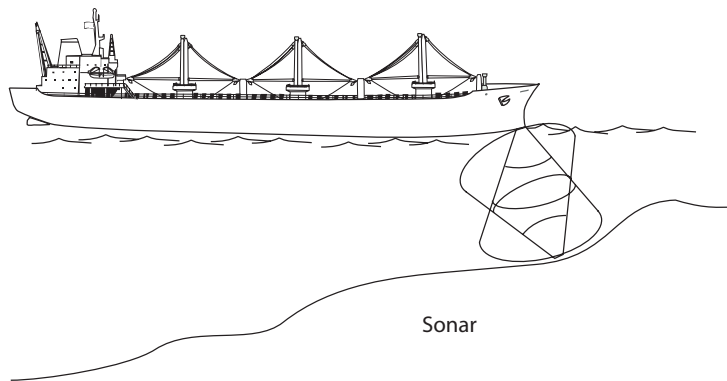
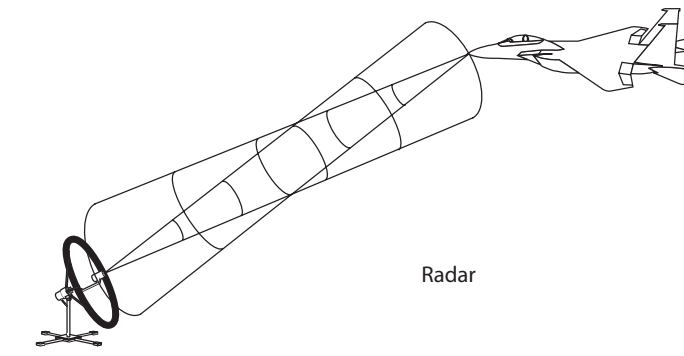

*Modulated backscatter technology is similar to RF systems used in air-traffic control systems, police radar systems, and marine sonar systems.*

## How Tags Affect the Reading Range

The RFID tags used in any installation significantly affect the dimensions and performance of the reading range. Among the primary tag characteristics that influence the reading range are:

- tag power source (battery or beam).
- tag orientation.
- tag speed through the reading range.
- tag mounting surface.
- tag sensitivity.
- tag reflectivity.

### Tag Power Source

Tags may be either active (powered by battery) or modulated backscatter (powered by the beam or radio signal). The active tag's performance (signal strength) declines gradually with distance, returning a progressively weaker signal. The modulated backscatter tag's reading range is limited by the need to receive adequate RF energy to energize its circuits. Its performance declines gradually until the received radio signal is insufficient to energize its circuits; beyond that point, no signal is returned.

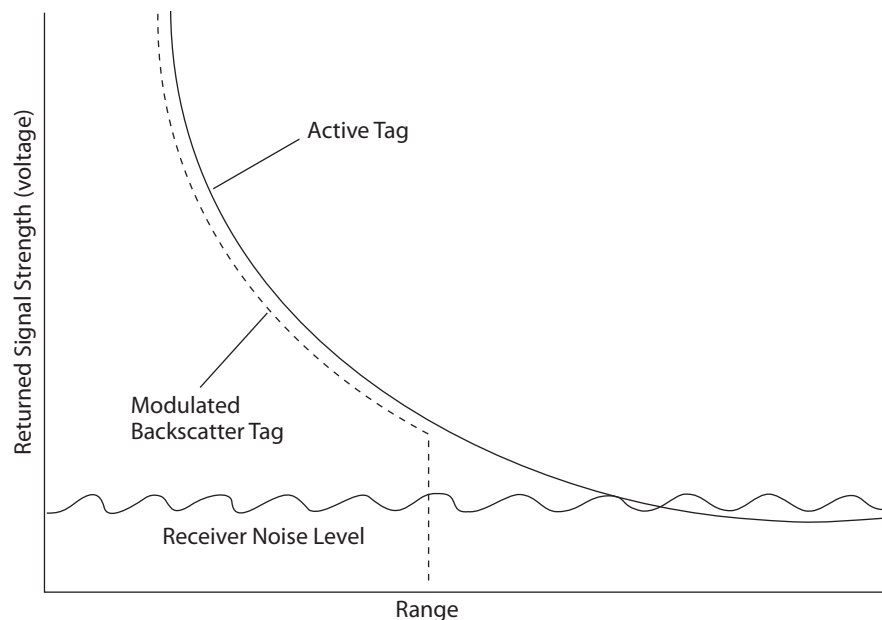

*This illustration shows the relative decline in performance of the active tag and the modulated backscatter tag. Notice that when the modulated backscatter tag can no longer receive adequate RF energy to energize its circuits, no signal is returned.*

## Tag Orientation and Placement

Tags are polarized just as are antennas. For optimal RFID system performance and reading range, tag polarization must be parallel with the applicable antenna's polarization. For most currently manufactured Intermec tags, the tag polarization is parallel with the tag's longer side.

Ideal alignment of the antenna and tag is with the tag directly in front of the antenna and the tag's longer side oriented parallel with the antenna polarization. Realistically, however, it is virtually impossible to guarantee ideal alignment of all tags to be read in a normal operation.

In all applications, the alignment of the tag antenna with the system antenna is important. The orientation of the tag in direct phase with the antenna pattern returns optimal results. However as a general rule, you may misorient the tag by  $15^\circ$  in any direction with negligible degradation in performance. Proper system configuration can permit even greater tolerance. This tolerance to misorientation allows the system to read tags whose orientation and angle of presentation change as a function of their trajectory through the reading range.

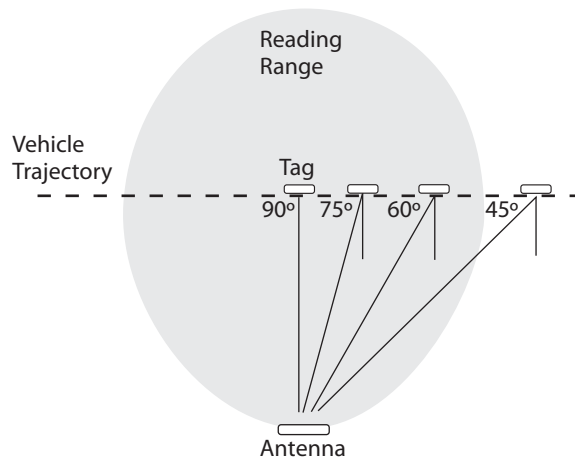

*This illustration shows a tag passing through the system antenna reading range. Note how the reading range is weaker when the tag is at greater angles to the antenna.*

Also, the tag reading range may be affected by pitch, roll, and yaw. These next definitions assume that antenna polarization is parallel with the tag's longer side.

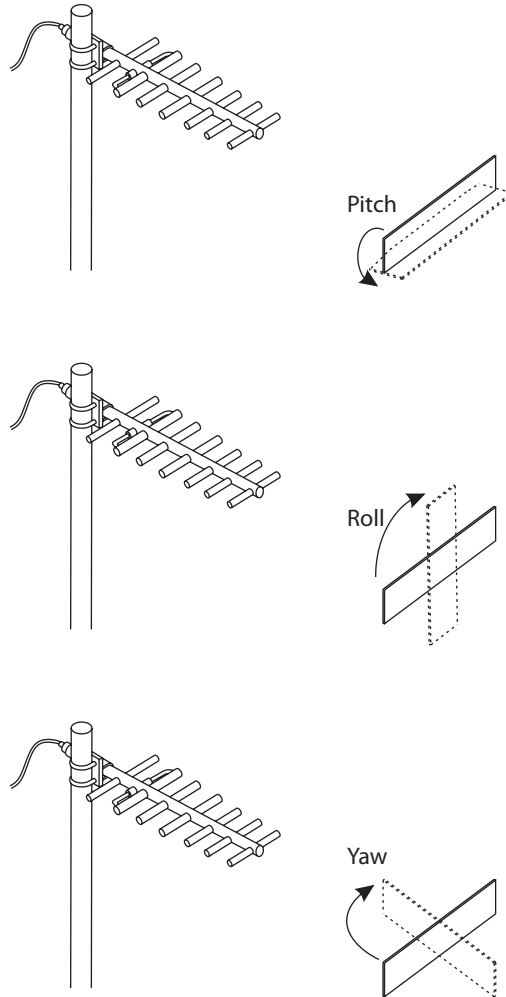

The tag reading range may be affected by pitch, roll, and yaw.

*Pitch* of the tag (front-to-back rotation about the horizontal axis) affects performance only slightly.

The rotation of the tag in a clockwise or counterclockwise manner (*roll*) results in a loss of performance. This loss increases as the rotation angle increases, and a null is observed as the angle approaches 90° from optimum. This is why orientation of the tag may be used to prevent reads in other far field antenna patterns.

End-on-end rotation of the tag around its vertical axis (*yaw*), is another consideration. As the angle from the antenna to the tag increases, the surface area of the internal tag antenna subjected to the far-field antenna pattern diminishes. This also results in the diminished readability of the tag.

Differences in mounting surface angle and height (such as exist between truck and sports car windshields), as well as changes in the angle of the tag as it passes through the range, are compensated for when adequate margin is allowed for less-than-optimal orientations and alignments.

## Tag Speed

The speed at which a moving tag can be read is limited by the need to receive a little more than one complete code frame while the tag is within reading range. For example, in certain circumstances, a reading range 1.5 m (5 ft) wide may support a maximum tag speed of 152.4 m/min (500 ft/min).

The data transfer rate is different from one air interface protocol to another. For example, the EPCglobal Gen 2 air interface protocol lets data rates vary by tag, reader, and application. However, in general, in order for the tag to move faster, you need to have a “cleaner” environment, which means stronger signals and fewer sources of noise.

## Tag Mounting Surface

The surface upon which a tag is mounted affects the tag’s performance, to a greater or lesser degree dependent on the tag type.

You may have a tag that is designed to perform best when it is mounted on a non-conducting surface, such as a cardboard box. Therefore, any metal or other conducting materials in the immediate vicinity of the tag affects its performance as they may create radio signal reflections, refractions, or shadows. The nearness of the box contents, especially metal contents, to the tag or a hand held behind the tag will also affect its performance as these factors can change the impedance of the tag’s internal antenna.

Another tag may be designed to perform best when mounted against a metal surface. The metal serves as a ground plane for the tag antenna, thus increasing the reading range. In applications requiring these tags to be mounted on non-metallic objects, you should install a metal backplane between the tag and the non-metallic object. This backplane should extend at least 5.1 cm (2 in) beyond tag edges on all sides.

## Tag Sensitivity

Tag sensitivity is defined as the ability of a tag to decode commands within the radio frequency stream, discerning data from electrical noise. This ability varies slightly among tags of the same type. The net effect of this variability is that a reader can read more sensitive tags at a greater distance than less sensitive tags.

In most Intermec UHF systems, this definition of tag sensitivity does not affect the reading range. What affects the reading range is the ability of a tag to be powered up by the reader in various environments. An environment that has only one reader is virtually noise-free and the reader may easily be able to power up the tag within a certain reading range. If several readers are added to this environment, they also add a lot of noise. The reading range for each reader may become significantly smaller.

## Tag Reflectivity

Tag reflectivity is defined as how effectively a modulated backscatter tag's antenna-switching circuit reflects energy back to the RFID reader. This ability is affected by materials used, pattern, and size. For example, if you want a tag with great reflectivity, make it using pure silver and make it (relatively) large.

## How to Choose the Right Tag

When you are choosing a tag for your application, you need to consider these factors:

- Frequencies and bandwidth
- Tag type
- Reading range performance
- Form factor
- Environment
- RFID standards compliance
- Cost

This section explains how Intermec tags may be appropriate for your application based on the above six factors. You will find more information on how to select the right RFID equipment for your application by going to [www.intermec.com/rfid](http://www.intermec.com/rfid) and then clicking **Brochures**.

## Frequencies and Bandwidth

All RFID systems must operate within national and international laws and regulatory guidelines with respect to frequency and bandwidth use. Depending on the country, several frequency bands may be available. Choose a frequency for your RFID equipment, including the tags, that matches your application and performance requirements.

Intermec's tag circuitry designs possess frequency agility, allowing for operation at 869 MHz and 915 MHz with a single design. The actual frequency of operation for a particular tag is determined by the tag's antenna design, but the same circuitry can be used regardless of which frequency is desired.

## Tag Type

Intermec provides RFID systems that use read/write tags and modulated backscatter technology (class 2 tags). Read/write tags are much more flexible than read-only tags or WORM tags and modulated backscatter tags are less expensive than active or active backscatter tags.

For supply chain asset management, using read/write tags lets you alter the data content of the tag according to your specific needs.

## Reading Range Performance

For any application, a tag's reading range is usually the primary gauge of its suitability. Intermec's tags can be read at distances up to 6 m (20 ft) or more from the system antenna and at speeds in excess of 152 m/min (500 ft/min). However, not all applications require maximum range.

Many of Intermec's tag designs, though optimized for maximum performance on specific materials, are often used with other materials for applications requiring less than optimal reading range, or where greater range may actually be detrimental. Note that the writing range is approximately 70% of the reading range.

## Form Factor

In general, larger tags provide better reading range performance. However, large tags are not always suitable for every application and you often need to choose between the tag size and its reading range performance.

Intermec has designed a portfolio of tag designs that use state-of-the-art materials to provide a wide range of options for combining size and performance.

## Environment

The tag location and how the tag is used can play a significant role in determining the right tag for your application. The reading range performance will differ depending on what materials are adjacent to the tag. Other environmental conditions such as temperature and humidity may also affect performance.

Intermec tags are available in a variety of designs and they use materials that are capable of surviving even the harshest environmental conditions, such as extreme heat or cold. Intermec tags have a high immunity to electrical noise and interference.

Generally, Intermec RFID systems can be specified to be virtually unaffected by factors such as precipitation, vibration, and dirt, encountered in normal operating circumstances.

## RFID Standards Compliance

Compliance to industry standards should play an important role when you are choosing RFID equipment. Intermec maintains an active presence within the worldwide RFID standards community and will continue to develop products that meet existing and emerging standards.

Intermec makes RFID equipment that supports both ISO 18000-6B and EPCglobal Gen 2 class 2. Any equipment that supports either of the standards are technically interoperable. Intermec's RFID equipment supports many other RFID technology standards. For a complete list, contact your local Intermec representative.



# **3 Learning About RFID Readers**

This chapter explains the type of RFID readers that you may use in your RFID system and how the reader you choose affects the RFID system.

This chapter covers these topics:

- Understanding RFID readers
- How readers affect RFID system performance
- How to choose the right reader

## Understanding RFID Readers

In the most general terms, RFID readers identify and communicate with RFID tags. The reader, which has one or more system antennas, generates and sends out RF energy, processes data returned by the tags in its reading range, and relays the tag data to a host system.

If your RFID system uses modulated backscatter (passive) tags, the reader must generate enough RF energy to energize the tags' circuitry so that the tag can reflect its data back to the reader. The reader may also write to tags.

Readers come in many different forms and can be used for many different applications in many different environments. There are fixed readers, portable readers, and vehicle-mount (forklift) readers. You can mount a fixed reader so that it can read tags traveling through dock doors, conveyor belts, loading bays, gates, doorways, and many other areas. You can use portable readers to add RFID capabilities to your existing application without investing in a new mobile computing system. You can also use portable readers to read and write to tags that are in remote locations.



**RFID Readers:** This picture shows an IF5 fixed reader.



**RFID Readers:** The left picture shows an IV7 vehicle-mount reader. The right picture shows an IP4 portable reader that is attached to a 700 mobile computer.

Intermec's UHF readers are able to read and write to ISO 18000-6b and EPCglobal Gen 2 Class 2 tags.

## How Readers Affect RFID System Performance

The reader has both active and passive influence on RFID system performance. Although inevitable, the effect of electrical noise and interference can be mitigated to an extent, through proper installation.

The outer boundary of the reading range is marked by the distance from the system antenna at which a tag can no longer be reliably read. This happens when the distance between the reader and a modulated backscatter tag becomes so great that the power of the radio signal is below the tag's sensitivity level. At the outer boundary, tag data will not be read with any degree of certainty.

### Reader Sensitivity

The reader's sensitivity is determined primarily by the electrical noise level of its internal circuitry. This noise competes (interferes) with the tag signal, and when sufficiently strong, the noise can overwhelm the tag signal in much the same way static can overwhelm a radio broadcast. Interference can be defined as any undesired electrical energy within the RFID system.

## Electrical Noise and Interference

The reader is also vulnerable to electrical noise from external sources, such as these two broad types:

- Sources that produce electrical noise when located in the RF field.
- Other sources of electrical noise.

### Sources That Produce Electrical Noise in the RF Field

Sources that produce electrical noise respond in the RF field in the same way a tag responds. When these tag-like signals return through the antenna, they may be strong enough to mask a real tag signal and prevent the reader from decoding the tag ID.

Examples of these sources commonly found in the environment are:

- other readers.
- fluorescent lights (AC).
- mercury and sodium vapor lamps (AC-powered street lights).
- camp lanterns (models which convert VDC to high-frequency AC).
- neon lights.

### Other Sources of Electrical Noise

Other sources of electrical noise may also be present in the environment. However, if you configure your RFID system properly, these sources will have little or no effect on system performance.

Examples of other sources of electrical noise are:

- high-speed fans with metal blades.
- high-speed trains.
- digital noise.
- cellular telephones (when switching on and off).
- microphonics caused by system vibrations or motions.

Some of these sources of electrical noise are not always easy to locate, since they often generate noise intermittently. The system designer or installer must be aware of such possible sources of noise and be prepared to compensate for them.

### Solving Electrical Noise and Interference Problems

The best way to compensate for sources of electrical noise is to remove the source from the RF field. Or, you can remove the source a sufficient distance from the antenna so that its signal level is far below that of the weakest expected tag signal.

When it is not practical to move either the source of the noise or the RFID system components, the source must be shielded with wire screen or other suitable material.

The type and length of cables used to connect system components can affect noise levels in the system and power output through the antenna. Long cable runs generally require heavier cable and a higher level of EMI (electromagnetic interference) shielding.

## How to Choose the Right Reader

Intermec readers can be grouped into four categories based on the answer to these two questions:

- Does the reader support more than one antenna?
- Do you want the decision making (intelligence) performed by the reader or by the host system?

Before you answer those questions, you also need to consider these factors:

- application type
- frequencies and bandwidth
- tag orientation and placement
- number of tags read at the same time
- tag speed
- location of filtering of redundant data (reader or host system)
- cost

This section explains which Intermec readers may be appropriate for your application based on the above factors. You will find more information on how to select the right RFID equipment for your application by going to [www.intermec.com/rfid](http://www.intermec.com/rfid) and then clicking **Brochures**.

## Application Type

When you are choosing readers for your application, the application itself should be the determining factor. The most common RFID applications are:

- conveyor reading
- portal reading
- stretch wrap station reading
- overhead reading
- mobile reading (using handheld devices)
- forklift reading

## Frequencies and Bandwidth

All RFID systems must operate within national and international laws and regulatory guidelines with respect to frequency and bandwidth use. Depending on the country, several frequency bands may be available. Choose a frequency for your RFID equipment, including the readers, that matches your application and performance requirements.

## Understanding Scanners and Smart Readers

Knowing where you want to filter redundant data and where you want to make decisions will help decide if you need a simple scanner or a “smart” reader.

### About Simple Scanners

Simple scanners rely on a host computer for filtering redundant data and making decisions. This host computer can be a tethered handheld computer (such as the 700 mobile computer) or a vehicle-mounted computer (such as the CV60). It can have a wired or wireless connection to a host computer. Simple scanners combined with a single antenna may offer a cost effective solution in this situation:

- there is already a local host computer (programmable logic controller or edge server) installed
- tags are consistently oriented the same way
- tags are always located in the same place
- few tags travel through the reading range at a time
- tags travel relatively slowly through the reading range.

If you use simple scanners with multiple antennas, it becomes less important to have tags consistently oriented and consistently placed. You can also increase the number of tags that are traveling through the reading range and the speed at which the tags are traveling.

### About Smart Readers

Smart readers provide real-time decision making based on the tag data. They can evaluate the tag data and respond to it. For example, they can trigger a red light to indicate that manual intervention is required. Since the reader makes the decisions, there is no communications delay because a server is down or busy.

Smart readers combined with a single antenna are often mobile and are the best solution for exception reading and subsequent rewriting of tag data. Smart readers combined with multiple antennas can cope with unpredictable tag placement, high tag volume through the reading range and high speed through the reading range. They can also provide local filtering.



# **4 Learning About RFID Antennas**

This chapter explains the type of RFID antennas that you may use in your RFID system and how the antenna you choose affects the RFID system. This chapter covers these topics:

- Understanding RFID antennas
- How antennas affect the reading range
- How to choose the right antennas

## Understanding RFID Antennas

Every RFID tag has an antenna and every RFID reader has either an integrated antenna or an external system antenna. An RFID antenna has two functions:

- Transmit the radio signal.
- Receive the coded signal transmitted or reflected by the tag.

Antennas come in many different forms and can be used for many different applications in many different environments. Here is an example of what an antenna may look like.



### **RFID Antenna**

Note that the radio signal that is transmitted from the reader through the antennas to modulated backscatter (passive) tags must be strong enough to energize (turn on) the tag's electronic circuitry. The radio signal must also be able to reflect off the tag and return an adequate number of complete tag messages to the antenna.

## How the Antennas Affect the Reading Range

Each antenna broadcasts RF energy in a characteristic radiation pattern. This pattern is the most influential factor determining the shape of the reading range. It radiates primarily in front of the antenna and is relatively symmetrical. When it is strong enough to communicate with a tag, the RF energy contained within the pattern is considered the “active” region. Beyond the active region, the antenna radio signal is too weak to reliably maintain a communications link between the tag and reader.

## Understanding Antenna Radiation Patterns

The antenna radiation pattern shows the antenna gain (a measure of antenna directivity), which determines the relative strength of the RF field within the antenna's pattern. In general, gain is expressed in dB (decibels) as the ratio of the maximum (forward) power density to the power density of an isotropic radiator emitting the same total amount of power. Its units are designated dBi, where the third letter ("i") means "over an isotropic."

An isotropic radiator is an imaginary source that emits radiation uniformly in all directions. Its radiation pattern is perfectly spherical in space. Note that the gain of an isotropic radiator that is radiating in a uniform spherical pattern is one (0 dB). By directing the radiator's energy, an antenna's power density may be concentrated along a preferred direction. This concentration of energy results in a power density gain in the designated direction.

A typical medium gain antenna has a gain of 10 dBi or more. This antenna pattern can be fan- or cone-shaped, with beam widths of 20 to 40 degrees. The field in front of an antenna varies gradually, so that the edges of the reading range are "soft."

## Understanding the Antenna Radiation Pattern Graphs

The antenna radiation pattern graph is part of each antenna's specification. It represents two-dimensional, horizontal or vertical "slices" of the antenna's three-dimensional field of broadcast relative to field intensity. It does not illustrate the absolute value of the relative field strength, but it displays the field strength at a given angle.

These graphs show the RF field strength for any direction measured at a fixed distance from the antenna. The outer concentric circles in the antenna pattern graphs show field strength changes in 1 dB increments, indicated by the numbers on the horizontal scale. Each dB corresponds to an attenuation ratio of approximately 1.12.

The antenna radiation pattern graphs apply only to the antenna's "far field." For Intermec antennas, the far field is considered to be a distance of 0.91 m (3 ft) or more from the antenna. In the "near field" (closer than 0.91 m or 3 ft), the radiation pattern serves only as an approximation of RF field distribution.

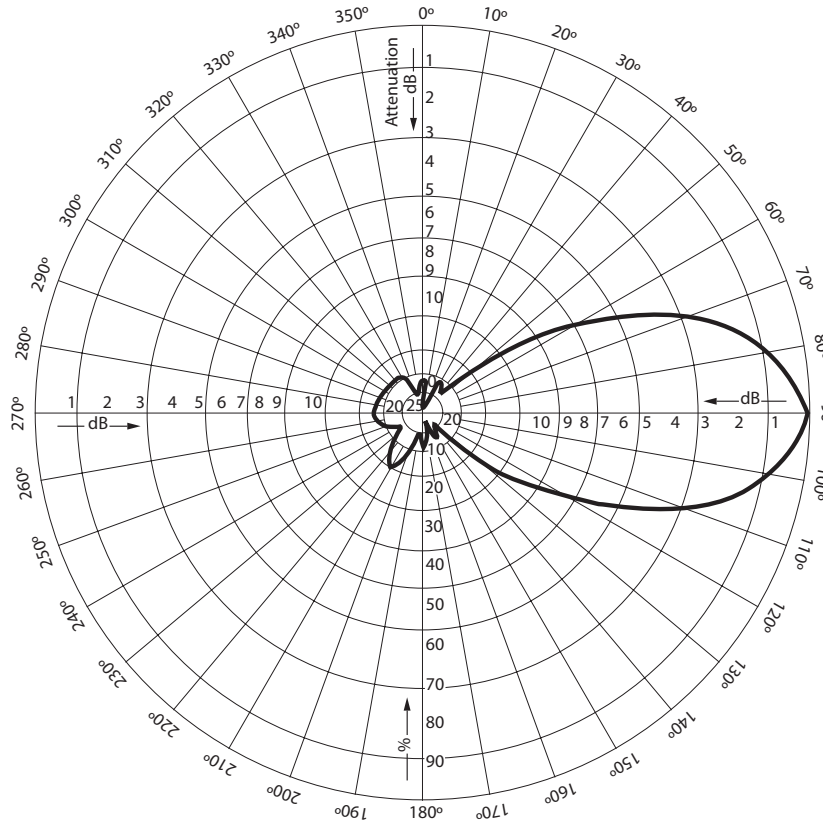

**Vertically-Polarized Yagi Antenna, Vertical Plane (Side View)**

The above illustration shows the vertical (side view) radiation pattern of a vertically-polarized Yagi antenna. The blimp-shaped contour represents the strength of the RF field as you move around the antenna. The antenna is located at the origin, which is in the center of the plot. The angle of observation is indicated by the numbers from 0° to 360° on the perimeter of the plot.

The 90° position on the graph corresponds to a location that is directly ahead of the antenna. The antenna emits its strongest signal in this direction. The 0° and 180° positions represent locations directly above and below the antenna, respectively. The antenna signal is much weaker in these regions.

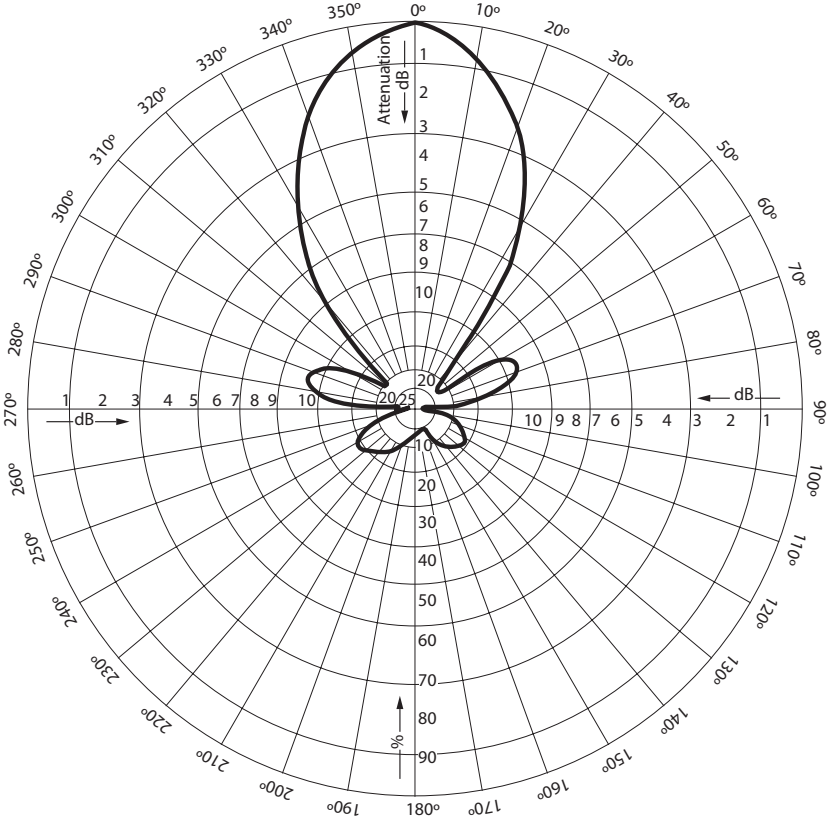

**Vertically-Polarized Yagi Antenna, Horizontal Plane (Polar View)**

The above illustration shows the horizontal radiation pattern of a vertically-polarized Yagi antenna. The 0° position on the graph corresponds to a location directly ahead of the antenna (equivalent to the 90° position in the vertical graph). The 90° and 270° positions represent locations to the extreme sides of the antenna.

**Lobes and Nulls in the Antenna Radiation Patterns**

Close examination of the antenna’s radiation pattern reveals small, but prominent peaks and gaps to the sides and rear of the pattern. These are called “lobes” and “null regions.” Their presence or absence is determined by the design of the antenna.

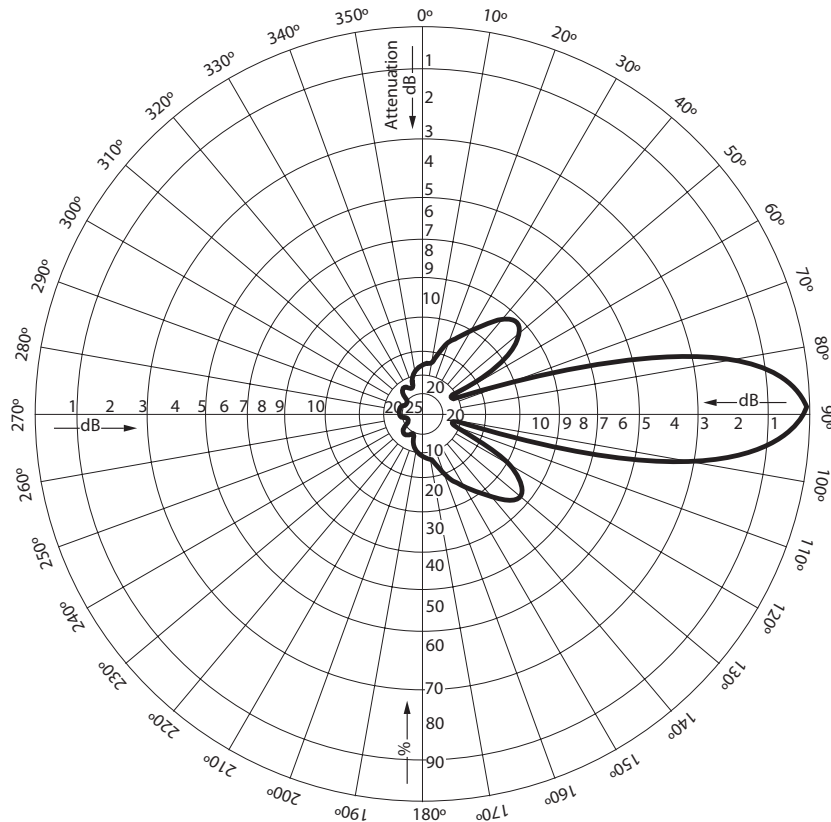

### ***Lobes and Null Regions in an Antenna's Vertical Plane***

Lobes in an antenna's field allow tags to be read in regions outside the field's primary active region. Although lobes typically represent fields between 15% and 30% of maximum field strength (or between 2% and 9% power density), they are often strong enough to read tags from behind, or to the extreme sides of the antenna. Generally, tag reading from these regions is undesired as it can interfere with the reading of tags passing through the optimal reading range to the front of the antenna.

Null regions are areas where the antenna field is relatively weak or absent. Null regions in the field will cause failure to read a tag which might otherwise be read.

## **About Attenuation**

Attenuation is the reduction of the amplitude of an electrical signal with little or no distortion. You can configure the attenuation of the radio signal, you can program it into an application, or attenuation can occur as a natural function of the environment. Conductive materials, such as saltwater, attenuate the radio signal as it passes through the medium.

You can also use attenuators to reduce the field strength in a controlled manner. Fixed-value signal attenuators can be installed in the line between the antenna and the reader or programmable signal attenuators can be designed into the reader and controlled by software. If you add attenuators to the antenna cable, they also attenuate the tag's modulated return signal, therefore use them with discretion.

You can also attenuate the field strength by changing the reader transmit power. Unlike an installed attenuator, this method does not affect the tag's return signal.

A common attenuation point on the dB scale is the 3 dB point. This point corresponds to a field strength that is 0.71 of maximum. The relationship between field strength and power density (inverse square law) that is discussed in the sections “Overall Signal Strength” on page 10 and “Modulated Backscatter Tags” on page 55 makes the 3 dB point equal to  $(0.71)^2$  or 0.50 (exactly half) of maximum power density.

Note that this definition differs from that of the field scale by a factor of two and may lead to some confusion between the scales. However, the factor of two is intentional so that 3 dB—whether it measures field strength or power density—always represents a factor of two change in power density.

## Measuring the Antenna's Radiation Region

When choosing antennas, the principal difference among them is the width of the active radiation region. One way to measure this width is by using half power beam width (HPBW). Each antenna is described by two half-power values. One value corresponds to the vertical plane, the other value represents the horizontal plane.

The HPBW is defined as that angle on the antenna radiation pattern that subtends a power density of at least 50% of the forward (maximum) power density. This angle corresponds to the point on the plot at which the contour crosses the 3 dB circle.

## How to Choose the Right Antennas

When you are choosing antennas for your application, you need to consider these factors:

- Application type
- Frequencies and bandwidth
- Reading range performance
- Environment
- Cost

All RFID systems must operate within national and international laws and regulatory guidelines with respect to frequency and bandwidth use. Depending on the country, several frequency bands may be available. Choose a frequency for your RFID equipment, including the antennas, that matches your application and performance requirements.

Most antenna radiation graphs only show the antenna's far-field performance. However, if you want your RFID system to have good coverage, you must address far-field performance and near-field performance.

For optimal system performance, most RFID systems require unique antennas. Intermec is working closely with Kathrein, Inc. to provide system antennas. Kathrein supports the RFID industry with both off-the-shelf antennas and special antenna products for specific applications, such as parking lot, toll plaza, container tracking, and rail.

For antenna integration support, contact:

Kathrein Inc., Scala Division  
Attention: Dan Fowler  
P.O. Box 4580  
Medford, OR 97501  
U.S.A.

Tel: 541-779-6500  
Cell: 541-840-9889  
Fax: 541-779-3991

e-mail: [dfowler@kathrein.com](mailto:dfowler@kathrein.com)

web site: [www.kathrein-scala.com](http://www.kathrein-scala.com)



# **5** Some Guidelines for Designing and Installing Your RFID System

Intermec can help you accurately evaluate RFID technology and integrate it into your business processes. Many companies have trusted Intermec to implement well-planned, smart, secure and seamless RFID systems. For large implementations and ongoing support, Intermec offers a number of other services—from project management, training and logistics coordination, to go-live support, service contracts and on-site preventative maintenance plans.

This appendix provides checklists for designing and installing your Intermec RFID system. It outlines guidelines for:

- designing your RFID system.
- installing your RFID system.

## Guidelines for Designing Your RFID System

When designing your RFID system, you need to decide which type of system you are designing, how you are going to approach the design of your system, and what kind of performance you need from your system. This section provides general guidelines that you should follow.

- Optimize tag-antenna orientation.
- Use horizontal polarization for tags which pass through reading range at various heights.
- Use vertical polarization to minimize ground effects.
- Avoid attempting to read tags more than twice the distance where the antenna main beam hits a major reflecting surface (such as the ground).
- Performance margin should be at least 6 dB, or twice the intended reading range for the average (standard) tag.
- Design for extraneous reads two or three times as far as intended reads.
- Turn on RF only when reading a tag.
- Tag should normally be in antenna field for 60 ms (single-channel operation; 240 ms for multiplex operation) to provide adequate margin above minimum. (Can be significantly shorter under special circumstances.)
- Where uninterrupted service is critical, use an uninterruptible power supply (UPS).

### How to Reduce Electrical Noise and Interference - General

This section outlines some of the major causes of electrical noise and how to reduce both the effects of noise and other interference. Some of the major causes of noise problems are:

- excessive wiring inductance (ground, or shield).
- excessive ground currents.
- undesired antennas.
- magnetic noise coupling.
- digital electronic noise.
- other sources of RF.

To reduce electrical noise, follow these recommendations, listed in descending order from most preferred:

- Positioning and separating
- Shielding
- Grounding
- Filtering

- Selection of RF frequencies

The most common shielding problems involve:

- coupling through apertures when  $D \geq \lambda/20$ , where  $\lambda$  represents the wavelength and D is the antenna dimension in wavelengths.
- incomplete shield coverage.
- cable shield acting as an antenna.
- conversion of a radiative wave to a surface wave.
- ground loops.

## **How to Reduce Electrical Noise and Interference - Specific Interference Types**

Conductive (direct contact) Coupling

- Move equipment
- Remove interference source

Inductive (magnetic) Coupling

- Reduce loop area
- Reduce dB/dt (time derivative of magnetic field)
  - Increase rise time
  - Increase separation from source
  - Use magnetic shielding

Capacitive (electric) Coupling

- Remove unnecessary ground connections
- Install isolation transformers
- Install longitudinal chokes

Radiative (electromagnetic) Coupling

- Absorb using lossy dielectric or magnetic material
- Reflect by installing metallic shield over source
- Install bandpass filters for interference frequency

### **Common Sources of Interference**

<b>Source of Interference</b>	<b>Type of Interference</b>
Fluorescent lights	Radiative
Mercury/sodium vapor lamps (street lights)	Radiative
Camp lanterns (converting VDC to high frequency AC)	Radiative
Neon lights	Radiative
High-speed fans with metal blades	Radiative
Electric motors connected to system power line	Inductive

**Common Sources of Interference (continued)**

Source of Interference	Type of Interference
Cellular phones (operating)	Radiative
Cellular phones (switching on and off)	Radiative
Generators (on same circuit)	Inductive
Generators (on different circuit)	Radiative
Digital electronics	Conductive/inductive

## Guidelines for Installing Your RFID System

- Point antenna only at tags to be read.
- Minimize reflections.
- Minimize ground bounce.
- Make cables between readers and antennas as short as possible, generally less than 6 m (20 ft).
- Areas where tag reading is not wanted should be twice the distance from position of farthest reading of strongest tag.

## Grounding Guidelines

- Use single point grounding for low frequency (<1 MHz) circuits.
- Use multipoint grounding for high frequency (>10 MHz) circuits.
- Use safety grounding which is permanent, continuous, low impedance, and which has adequate capacity for fault current.
- Ensure the safety grounding conductor does *not* carry current under normal conditions.
- Use separate *signal* and *power* grounding systems.
- Avoid capacitively coupled instrumentation ground loops.
- Establish the signal ground at the lowest level stage and connect all succeeding stages to this ground by separate conductors.
- Carefully evaluate in advance the interconnection of earth grounds for separate buildings.
- Ground the RFID module shield at the reader only.
- Ground the proximity sensor shield at reader (generally).
- Ground the communication equipment shield at either end, but *not* at both ends.

A *low noise* grounding system can be established by employing the following techniques:

- Isolate equipment racks from building steel
- Use insulated equipment grounding conductors

- Ensure only compatible equipment share a common grounding conductor

## **Shielding Guidelines**

- Physically separate low level signals from high level signals, digital signals, or power lines and grounds.
- Keep shielding conductors free of signal and power currents.
- Terminate low frequency (<1 MHz) shields at only one point. Do not leave shields floating.
- Use twisted signal leads to provide significant inductive shielding.
- Assume no shielding action exists when the outer conductor of a coaxial cable is used as a low frequency signal return.
- Wherever possible, ground high frequency shields repeatedly.
- Consider inductive coupling a more serious concern for low impedance circuits.





# **A Other Helpful Information**

## Calculations

When designing your Intermec RFID system, you may find these formulas to be helpful if you need to calculate certain parameters.

### Tag Formulas

These are summaries of formulas that are most commonly used for tags.

#### Battery-Powered Tags

These calculations assume that noise levels and antenna gain are constant. Because these factors are often not constant, the  $r^4$  prediction must be used only as a guide to actual system performance.

The following formulas assume that you know the tag's maximum reading range and power level. They use these variables:

$r$  = maximum reading range allowed

$r'$  = tag's maximum reading range

$P$  = tag's power level

$P'$  = maximum power level allowed

If you know the maximum power level allowed and want to calculate the maximum reading range allowed, use the following formula:

$$r = r' \sqrt[4]{\frac{P}{P'}}$$

If you know the maximum reading range allowed and want to calculate the maximum power level allowed, use the following formula:

$$P = \frac{r^4 P'}{r'^4}$$

For example, assume a battery-powered tag has a maximum range of 90 ft at a transmitted power of 2 W. The maximum range in a country where transmitted power level is 50 mW, is calculated as follows:

$$r = r' \sqrt[4]{\frac{P}{P'}}$$

$$= 90_{feet} \sqrt[4]{\frac{(0.05 W)}{2 W}}$$

$$= 35.8 \text{ feet}$$

### Modulated Backscatter Tags

The reading range of modulated backscatter tags is determined primarily by the requirement to capture enough energy from the reader radio signal to power the tag.

The inverse square law, which describes the relationship of power density to distance from the antenna, is the principal criterion that determines the range of a tag. That is, “The power density of the radio signal decreases as the inverse square of the distance from the antenna.”

The following formulas assume that you know the tag’s maximum reading range and power level. They use these variables:

$r$  = maximum reading range allowed

$r'$  = tag’s maximum reading range

$P$  = tag’s power level

$P'$  = maximum power level allowed

If you know the maximum power level allowed and want to calculate the maximum reading range allowed, use the following formula:

$$r = r' \sqrt{\frac{P}{P'}}$$

If you know the maximum reading range allowed and want to calculate the maximum power level allowed, use the following formula:

$$P = \frac{r'^2 P'}{r^2}$$

## Antenna Formulas

These are summaries of formulas that are most commonly used for antennas and field strength.

### Relationship Between Field Strength and Power Density

The overall radio signal strength is influenced by three factors: power density, field strength, and antenna power.

Power density for radio signals in free space is proportional to the square of field strength. That is, doubling the field strength quadruples the power density. The relationship of power density to field strength can be expressed by:

$$P_d = \frac{E^2}{377}$$

where:

$P_d$  is the power density, in  $W/m^2$  (watts per square meter) for radio waves in open space.

$E$  is the RMS (root mean square) field strength (in volts per meter).

377 is a constant representing the impedance of free space.

### **Converting Field Strength to Decibels (dB)**

In addition to the percentage scale, the relative strength of the radio signal can be expressed in dB. On the decibel scale, the field strength is expressed as the logarithm of the ratio of the field strength to a reference field strength. The formula to convert field strength to dB is:

$$E_{dB} = 20 \left( \log_{10} \frac{E}{E_r} \right)$$

where:

$E_{dB}$  is field strength in dB.

$E$  is field strength in V/m (volts per meter).

$E_r$  is strength of reference field in V/m.

Every 20 decibels corresponds to a factor of 10 times the field strength. Zero dB corresponds to a ratio of one (no attenuation), while 20 dB corresponds to a ratio of 10, and 40 dB corresponds to a ratio of 100.

### **Converting Power Density to Decibels (dB)**

Power density ratios may be expressed on the dB scale as follows:

$$P_{dB} = 10 \left( \log_{10} \frac{P}{P_r} \right)$$

where:

$P_{dB}$  is power density in decibels.

$P$  is power density in  $W/m^2$ .

$P_r$  is the reference power density in  $W/m^2$ .

Note that this definition differs from that of the field scale by a factor of two and may lead to some confusion between the scales. However, the factor of two is intentional so that 3 dB—whether it measures field strength or power density—always represents a factor of two change in power density.

## How Readers Decode the Radio Signal

Binary characters recognized by the RFID system are made up of sets of ones and zeros (bits) arranged in distinctive patterns. The binary character “A” (six-bit code related to ASCII format) is coded “100001.”

Just as units of measurement are made up of progressively smaller increments (1 yard = 3 feet = 36 inches), by which increasingly precise measurements can be made, so too does the binary language of the tag message comprise several layers of data in progressively finer increments.

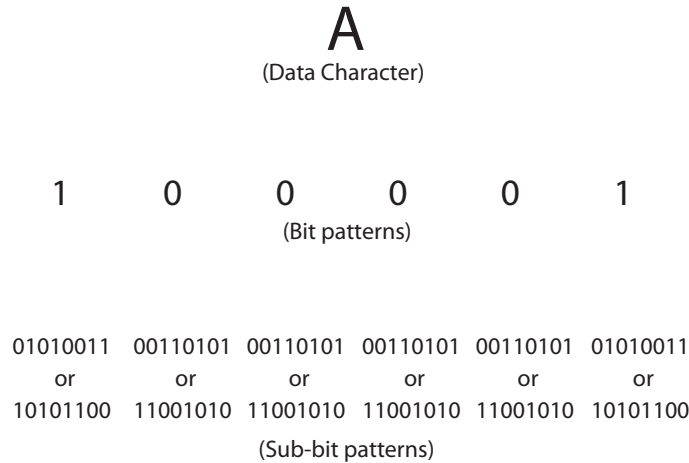

### **Example: Breakdown of Digital Data Components, From Character to Signal**

For example, when the data is expressed by the radio signal in sequences of signals of different frequencies, it is using a modified frequency-shift keying (FSK) process. A “1” may be defined as two cycles of 40 kHz followed by one cycle of 20 kHz. A “0” may be defined as one cycle of 20 kHz followed by two cycles of 40 kHz. A frame marker is denoted by six cycles of 40 kHz and one cycle of 20 kHz.

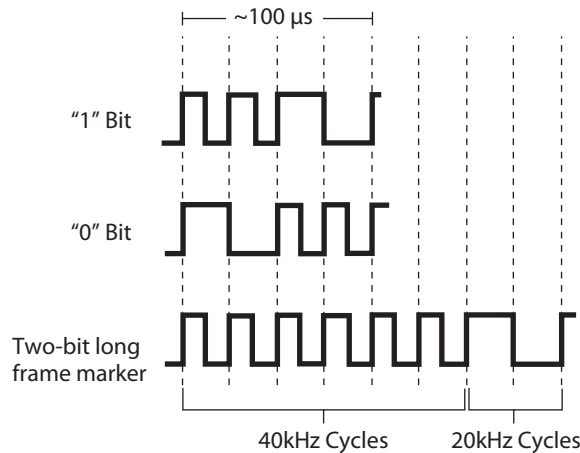

### **Frequency-Shift Keying (FSK) Encoding**

***Appendix A — Other Helpful Information***

Because the tag data is contained solely in the modulating frequencies, the polarity of the signal is of no consequence.



## Index

### A

active backscatter tags, 24  
  formulas, 54  
  life, 17  
  technology, understanding, 23

active tags, 7, 24  
  definition, 6  
  formulas, 54  
  life, 17  
  performance, understanding, 27  
  technology, understanding, 23

air interface protocols standards, 4

antenna  
  attenuation, understanding, 44  
  formulas, 55  
  gain  
    and the radio signal, 10  
    definition, 10  
    determining, 41  
    vs. field strength, 11  
  misorientation, tolerance, 28  
  orientation, 17  
    influence on reading range, 15, 28  
  power density, directing, 41  
  radiation pattern, understanding, 41  
    graphs, 41  
    influence on reading range, 15  
    lobes and null regions, 43  
  radiation region, measuring, 45  
  reading range, influences, 40  
  selection considerations, 45  
  types, Intermec, 19  
  understanding, 40

applications  
  RFID systems, examples, 37  
  standards, 4

attenuation, understanding, 44

### B

bandwidth, about, 5, 31, 38, 46

bar code systems, compared to RFID systems, 2

battery-powered tags, 24  
  *See also* active backscatter tags.  
  *See also* active tags.

beam-powered tags, 24  
  *See also* modulated backscatter tags.

block diagram, tag, 24

### C

calculations, 54

capacitively-coupled tags, 7  
  definition, 6, 25  
  guidelines for reducing electrical noise, 49

capture window, defined, 15  
  *See also* reading range.

channels  
  primary service, 8  
  secondary service, 8

code frame, reading, 16, 30

conductive coupling, guidelines for reducing  
  electrical noise, 49

conformance standards, 4

constructive interference, 13

continuous-wave radio signal, 9, 20

controlling RFID system performance,  
  methods, 19

copyright information, Intermec, ii

### D

data content standards, 4

designing your RFID system guidelines, 48

diffraction, 11  
  understanding, 12

duty cycle, 8

### E

electrical noise, 17  
  guidelines for reducing  
    general, 48  
    specific types, 49  
  influences, 11, 17  
    on reading range, 16  
    on RFID system, 15  
  reader vulnerability, 35  
  removing, 36  
  sources, 36

electronic ID systems, defined, 2

environmental capabilities, RFID systems, 18, 20

EPCglobal standards, 4  
  Intermec supported, 19

error rate, reading, 18

### F

far-field systems, 19  
  definition, 6  
  Intermec, 41

field strength  
  and the radio signal, 10  
  definition, 10  
  vs. antenna gain, 11

formulas  
  antenna, 55  
  tag, 54

frequencies  
  about, 5, 31, 38, 46  
  Intermec supported, 20

frequency hopping signals, 20

**G**

gain, *See* antenna gain.  
 grounding, guidelines, 50  
 guidelines  
   bandwidth and frequency, 31, 38, 46  
   designing your RFID system, 48  
   grounding, 50  
   high frequency systems, 7  
   installing your RFID system, 50  
   low frequency systems, 6  
   microwave systems, 7  
   reducing electrical noise  
     general, 48  
     specificity types, 49  
   reducing interference  
     general, 48  
     specific types, 49  
   shielding, 51  
   UHF systems, 7

**H**

half power beam width (HPBW),  
   understanding, 45  
 harmonics, tag, 17  
 high fields, *See* reading ranges, extended.  
 high frequency systems, 5  
   reading range, 7  
   regulatory agency guidelines, 7  
   tags, 7  
   understanding, 7  
 homodyne system  
   radio signals, 20  
   understanding, 9

**I**

identification systems, defined, 2  
 inductively-coupled tags, 6, 7  
   definition, 6, 25  
   guidelines for reducing electrical noise, 49  
 installing your RFID system, guidelines, 50  
 interference, 17  
   common sources, 49  
   constructive, understanding, 13  
   guidelines for reducing  
     general, 48  
     specific types, 49  
   influences on reading range, 16  
   reader vulnerability, 35  
   removing, 36  
 Intermec  
   frequency and power, supported, 20  
   RFID standards supported, 5  
   RFID systems  
     environmental capabilities, 20

    frequency and power, supported, 20  
     operational characteristics, 19  
     radio signals, 20  
     reading range, 20  
     supported, 19  
   service and support, vii  
   telephone support, viii  
   warranty information, vii  
   web support, vii  
 interrogator, *See* reader.  
 inverse square law, 11  
 ISO standards, 4  
   Intermec supported, 19  
 isotropic radiator, defined, 41

**L**

laser, 2  
 laws, *See* regulatory agencies.  
 lobes  
   antenna radiation patterns, understanding, 43  
   illustrated, 44  
 low fields, *See* null regions, avoiding.  
 low frequency systems, 5  
   reading ranges, 6  
   regulatory agency guidelines, 6  
   tags, 6  
   understanding, 6

**M**

manual  
   audience, viii  
   copyright information, ii  
   icons, vii  
   overview, viii  
   related documents, downloading, ix  
   safety information, vii  
   telephone support, viii  
   warranty information, vii  
   web support, vii  
 microwave systems, 6  
   reading range, 7  
   regulatory agency guidelines, 7  
   tags, 7  
   understanding, 7  
 modulated backscatter tags, 6, 7, 25, 31  
   definition, 6  
   formulas, 55  
   life, 17  
   performance, understanding, 27  
   technology, understanding, 23, 26  
 mounting surface, 17  
   influence on reading range, 15, 30  
 multipath, 11  
   avoiding null regions, 14

## Index

- multipath (*continued*)
  - illustrated, 12
  - understanding, 13
  - using to extend reading range, 13, 18
- N**
- near-field systems
  - definition, 6
  - Intermec, 41
- network diagrams, examples, 3
- noise, *See* electrical noise.
- null regions
  - antenna radiation patterns, understanding, 43
  - avoiding, 14, 18
  - illustrated, 44
- O**
- obstructions, influence on reading range, 15
- operational characteristics, 15, 19
- orienting
  - antennas, 17, 28
  - tags, 17, 28
    - pitch, defined, 28
    - roll, defined, 28
    - yaw, defined, 28
- P**
- passive tags, *See* modulated backscatter tags.
- performance, RFID systems
  - controlling, 19
  - influences on, 15
  - radio waves, 11, 18
  - reader influences, 35
- pitch, antennas and tags
  - definition, 29
  - illustrated, 29
- placement, antennas and tags, 17, 28
- polarization, *See* tag orientation.
- power
  - density, 11
    - and the radio signal, 10
    - definition, 10
  - levels supported by Intermec, 20
- power levels, 8
- propagation-coupled tags, *See* capacitively-coupled tags.
- pulsed radio signal, 9, 10
- R**
- radiation pattern, *See* antenna radiation pattern.
- radiative coupling, guidelines for reducing electrical noise, 49
- radio energy, *See* radio waves.
- radio frequency, defined, 2
- radio signals
  - electrical noise, influences, 11
  - frequency hopping, 20
  - homodyne, 20
  - illustrated, 9
  - influences, 10, 18
  - reader, decoding, 57
  - strength influences, 10
  - table, 9
  - understanding, 8
- radio waves
  - diffraction, understanding, 12
  - influences on RFID system, 11
  - materials penetration, 18
  - multipath, understanding, 13
  - reflection, understanding, 12
  - refraction, understanding, 12
- radio-wave-coupled tags, *See* inductively-coupled tags.
- range, *See* reading range.
- read/write tags, 23
- reader
  - decoding the radio signal, 57
  - definition, 4
  - electrical noise, 36
  - examples, 34, 35
  - illustration, 2
  - influences on RFID system, 35
  - power
    - influence on reading range, 15, 30
    - using with active backscatter tags, 24
    - using with modulated backscatter tags, 25
  - selection considerations, 37
  - sensitivity, influence on reading range, 35
  - simple scanners, when to use, 38
  - smart readers, when to use, 38
  - understanding, 34
- reading error rate, 18
  - influences on RFID system, 15
- reading range, 20
  - antenna influences, 40
  - avoiding null regions, 14, 18
  - controlling, 16
  - definition, 15
  - extended areas, 18
  - in high frequency systems, 7
  - in low frequency systems, 6
  - in microwave systems, 7
  - in UHF systems, 7
  - influences, 15
    - tags, 32
  - primary factors, 15
  - tag influences, 27

- reading range (*continued*)
    - using multipath to extend, 13
  - reading speed, 15, 16, 20
    - increasing, 16
    - influences, 15
  - read-only tags, 23
  - reflection
    - controlling, 12
    - understanding, 12
  - reflectors, influence on reading range, 15
  - refraction, 11
    - understanding, 12
  - regulatory agencies, 32
    - and the RF spectrum, 5
    - channels, 8
    - duty cycles and power levels, 8
    - frequency, 5, 31, 38, 46
    - high frequency systems, guidelines, 7
    - low frequency systems, guidelines, 6
    - microwave systems, guidelines, 7
    - UHF systems, guidelines, 7
  - RF diffraction, *See* diffraction.
  - RF energy, *See* radio waves.
  - RF reflection, *See* reflection.
  - RF refraction, *See* refraction.
  - RF signals, *See* radio signals.
  - RF spectrum, 5
  - RF, *See* radio frequency.
  - RFID antennas, *See* antenna.
  - RFID readers, *See* reader.
  - RFID standards
    - Intermec equipment, 5
    - understanding types, 4
  - RFID systems
    - about, 2
    - advantages of, 2, 4
    - channels, 8
    - compared to other bar code systems, 2
    - components, 3
    - definition, 2
    - designing guidelines, 48
    - duty cycle and power levels, 8
    - example, 2
    - frequencies, 5
    - high frequency systems, understanding, 7
    - installing guidelines, 50
    - Intermec, 31, 38, 46
    - low frequency systems, understanding, 6
    - microwave systems, understanding, 7
    - network diagrams, 3
    - operational characteristics, 15
    - performance
      - controlling, 19
      - influences on, 15
      - radio waves, 11, 18
      - reader influences, 35
    - radio signals, understanding, 8
    - standards, 4, 32
    - UHF systems, understanding, 7
  - RFID tags, *See* tag.
  - roll, antennas and tags
    - definition, 29
    - illustrated, 29
  - rusty joint problems, 17
- S**
- safety information, vii
  - semi-passive tag, *See* active backscatter tags.
  - service and support, Intermec, vii
  - shielding, guidelines, 51
  - signals, *See* radio signals.
  - simple scanners, when to use, 38
  - smart labels, *See* tag.
  - smart readers, when to use, 38
  - spectrum, *See* RF spectrum.
  - speed, *See* reading speed.
  - standards, *See* RFID standards.
  - swept frequency radio signal, 9, 10
- T**
- tag
    - active backscatter, understanding, 24
    - active, understanding, 24
    - block diagram, 24
    - capacitively-coupled, defined, 25
    - data, influences on RFID system, 15
    - definition, 4
    - environment, influencees on reading range, 32
    - examples, 22
    - form factors, influences on reading range, 32
    - formulas
      - for battery-powered tags, 54
      - for modulated backscatter tags, 55
    - frequencies supported by Intermec, 20
    - harmonics, 17
    - inductively-coupled, defined, 25
    - Intermec, 31
    - life, 17
      - influences on RFID system, 15
    - modulated backscatter, understanding, 25, 26
    - mounting surface, 17
      - influence on reading range, 15, 30
    - orientation, 17
      - influence on reading range, 15, 28
      - influences on RFID system, 15
    - pictures, 22
  - tag

## Index

### tag (*continued*)

- power source, influence on reading range, 15, 27
- read/write, understanding, 23
- reading error rate, understanding, 18
- reading range, influences, 27
- read-only, understanding, 23
- reflectivity
  - definition, 31
  - influence on reading range, 31
- selection considerations, 31
- sensitivity
  - definition, 30
  - influence on reading range, 15, 30
- signals, degradation due to environment, 18, 36
- size, influences on reading range, 32
- speed, influence on reading range, 15, 30
- technologies, understanding, 23
- types
  - in high frequency systems, 7
  - in low frequency systems, 6
  - in microwave systems, 7
  - in ultra-high frequency systems, 7
  - modulated backscatter, 31
- understanding, 22
- WORM, understanding, 23
- telephone support, Intermec, viii
- transponders, *See* tag.

troubleshooting, rusty joint problems, 17

## U-V

- UHF systems, 6, 19
  - reading range, 7
  - regulatory agency guidelines, 7
  - tags, 7
  - understanding, 7
- ultra-high frequency systems, *See* UHF systems.
- understanding tag technologies, 23
- visual scanning systems, compared to RFID systems, 2

## W

- warranty information, Intermec, vii
- web support, Intermec, vii
- WORM tags, 23
- write-once/read-many tags, *See* WORM tags.
- writer, *See* reader.
- writing range, understanding, 32

## Y

- Yagi antenna, vertically-polarized
  - horizontal plane, illustrated, 43
  - vertical plane, illustrated, 42
- yaw, antennas and tags
  - definition, 29
  - illustrated, 29





**Corporate Headquarters**  
6001 36th Avenue West  
Everett, Washington 98203  
U.S.A.

**tel** 425.348.2600

**fax** 425.355.9551

[www.intermec.com](http://www.intermec.com)

Intermec RFID System Manual



P/N 936-000-001