

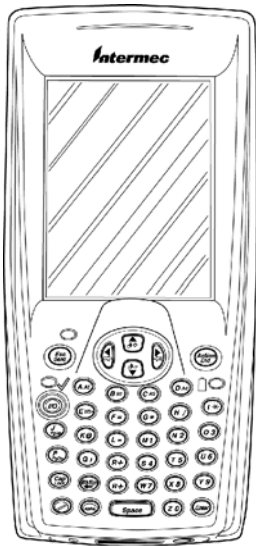

Intermec



**Quick Start
Guide**



**751G
Alpha
Mobile
Computer**

Thank you for purchasing the Intermec 751G Series Color Mobile Computer. You will find your 751G Computer useful in a variety of data collection and data management applications. Its integrated peripherals and rugged design ensure reliable service for years to come.

This guide provides information needed to get started using your 751G Computer. For more detailed information refer to “Where to Find More Information” of this guide.

Note that the hardware configuration of your 751G Computer may differ from the descriptions in this guide. Software operation descriptions are based on factory defaults.

Your 751G Alphanumeric Computer is available as a batch (store and forward) device and with a radio for direct communication with the host computer. You can distinguish which your device is by the label on the back. The batch model is 741G7200EB16S000 and the radio model is 751G7200EB16S804.

Contents

751G Computer Mobile Computer Description	5
Setting Up Your 751G Computer	7
Non-Incendive (NI) Cautions	8
Learning About The Keypad	8
Gold/White Plane Keys	8
Alpha (Blue) Plane Keys-Numeric Keypad	9
Scanning/Keypad Shift and Notification LED	9
Action and Up/Down Navigational Buttons	9
Battery Status LED	10
About Microsoft Windows CE Software	11
The Desktop Screen	11
Start Menu	12
Customizing your Desktop	12
Task Bar	13
Pop-up Menus	14
Entering Information into Your 751G Computer	15
Warm Resetting Your 751G Computer	16
Cold Resetting Your 751G Computer	16
Troubleshooting	17
Cleaning Your 751G Computer	18
Case and Display	18
Where to Find More Information	18

Radio Use Safety Precautions	19
End User License Agreement	20
Microsoft Windows CE.Net	20
Intermec Technologies Corporation End User License Agreement	24
Global Services and Support	25
Warranty Information	25
Web Support	25
Telephone Support	26
Patent Information	27

751G Computer Mobile Computer Description

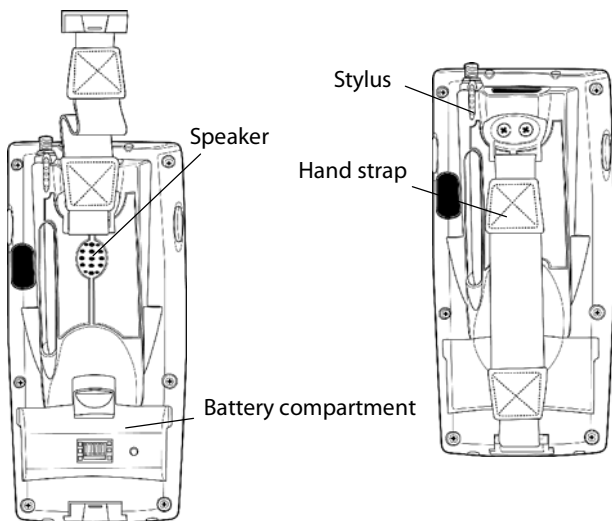
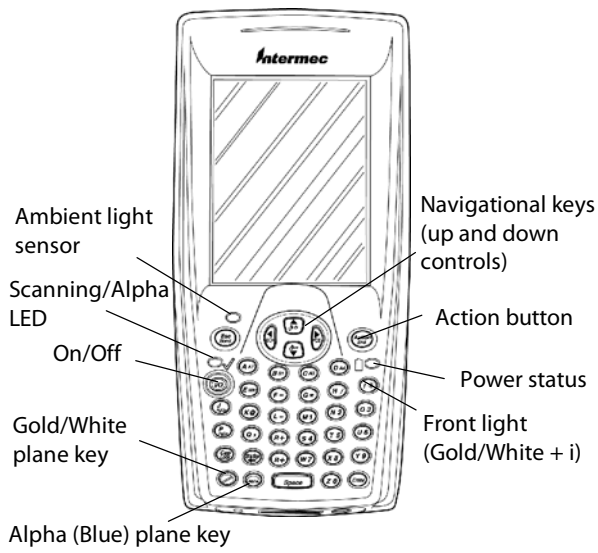

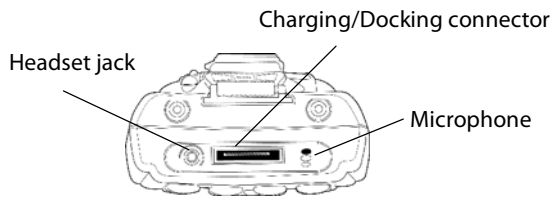
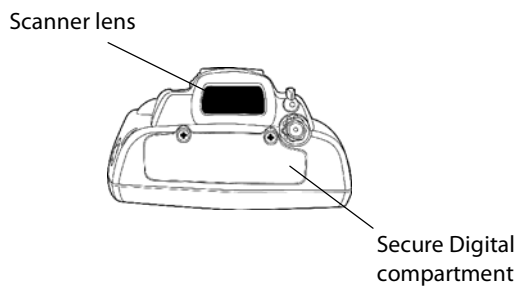
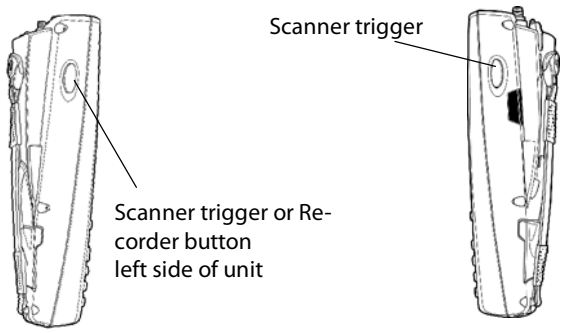

Setting Up Your 751G Computer

- 1 Remove 751G Computer from its packaging.
- 2 Release hand strap and connector cover.

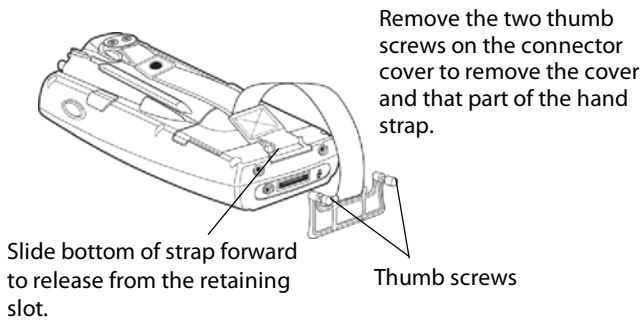

- 3 Install battery and reattach hand strap and connector cover.

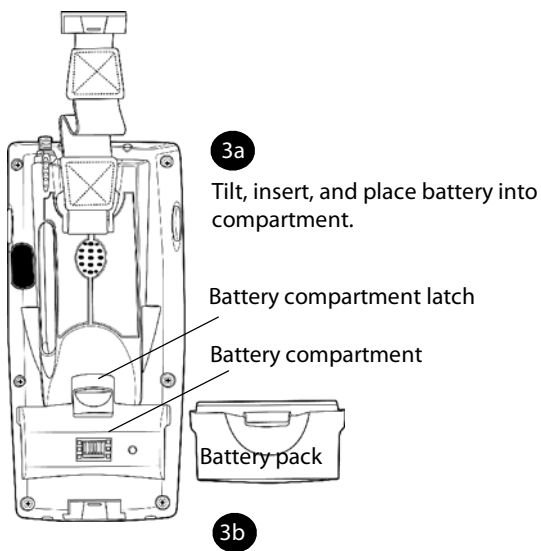

Ensure battery compartment latch clicks so battery is secure in compartment.

- 4 Insert your 751G Mobile Computer into the 751G Single Dock for charging.
- 5 Charge battery pack (3 hours) before using. However, to ensure proper charging, perform the remaining steps first, with the AC adapter or dock connected.
- 6 The first time you turn on your 751G Computer it boots to the operating system. After a few seconds you see the Windows CE.Net Desktop screen. Tap your stylus to advance to the next display on the screen.
- 7 You will be prompted through the several screens to complete the setup process. Read the display messages and follow the instructions. When you reach the Windows CE.Net Desktop screen, you have completed the setup.

Non-Incendive (NI) Cautions



Caution

Do not use the Charger in an NI environment.



Do not swap or charge batteries in an NI environment.

Ensure that the Connector door on the bottom of the unit is in place in an NI environment.



Learning About The Keypad



Gold/White Plane Keys



The Gold/White  plane keys provide you access to display controls, special characters, and Windows CE.Net options.

Press the Gold/White  key for each gold plane key stroke you wish to make. For example to turn on the front light, press and hold the Gold/White  key plus the 'i' key. To turn the front light off press the appropriate keys again.

Alpha (Blue) Plane Keys-Numeric Keypad

The Alpha (Blue)  plane keys work a bit differently than the gold plane keys. When you press the Alpha key, the Scanning/Alpha  LED lights 'red' to indicate Alpha mode. The keypad stays in the Alpha mode until you press it again.

For example, pressing the Alpha  key and the  key allows the next letter to be capitalized. Again it stays in this mode until you press the Alpha key again.

If you want to type a 'c' press the  key and the  key three times. If you need a letter that is on the same key as the last letter entered, wait two seconds after you pressed the last key then you can enter the correct series of keystrokes to create the next letter.

Scanning/Keypad Shift and Notification LED

The Scanning/Keypad Shift and Notification LED  turns red, or green.

- **Momentary Green:** Indicates a 'good scan'.
- **Blinking Green:** Indicates that the scanner is initializing.
- **Steady Red:** Indicates the keypad is shifted to the Alpha (Blue) plane and the 751G is On.

Action and Up/Down Navigational Buttons

- **Action** button: Press to open an item (similar to pressing ENTER on the keypad).
- **Up/Down** controls: Press to scroll through a list (similar to pressing the arrow keys on a keyboard).

Battery Status LED

Power to run your 751G Computer is supplied by a powerful Li-Ion battery pack designed to give you approximately 6-10 hours of operation (depending on application). In addition, your 751G Computer contains backup capabilities to prevent loss of data when the main battery is discharged or when switching out battery packs.

For **maximum** effectiveness it is important to leave the main battery installed in your 751G Computer even if it is discharged. **If the main battery is removed, it should be replaced within 10 minutes to avoid the possibility of data loss. Before removing the battery ensure the 751G Computer is in *sleep* mode.**

The Battery status LED  turns red, green, or yellow.

- **Steady Green:** Battery is more than 95% charged and unit is on a charger.
- **Blinking Red:** Battery is low. The speed of the blinking increases as the battery's power gets increasingly lower.
- **Red:** Main battery is low, or if charging, will remain red until your 751G Computer reaches 95% charge status.
- **Yellow:** Your 751G Computer is on a charging source and there is no battery pack installed. Can also mean that your 751G Computer is out of charging range 32° to 122°F (0° to 50°C). Once your 751G Computer gets back in range, charging resumes and the LED changes to red or green.
- **Alternating between Red and Yellow:** The battery pack needs replacing.

About Microsoft Windows CE Software

Your 751G Computer comes with Microsoft Windows CE.Net preloaded. For more information regarding:

- Programs on your device: See the *751G Mobile Computer User's Manual* (p/n: 961-054-036) or access the Help screen on the Start Menu. To view Help, tap  then tap Help.
- Connecting to and synchronizing with a desktop computer: ActiveSync Help on your desktop computer. To view Help, click Help and then Microsoft ActiveSync Help.

The Desktop Screen

When you turn on your 751G Computer for the first time each day you'll see the Desktop screen. You can also display it by tapping  on the task bar.



Start Menu

The Start menu is located at the bottom of the screen. It displays the active programs, current time, and allows you to switch to programs and close screens.



Start Menu
button

Customizing your Desktop

To customize your Desktop, tap  Start > Control Panel > Display.

Task Bar

The Task Bar is displayed at the bottom of the screen. Use the Task Bar at the bottom of the display to perform tasks in programs. The Task Bar includes menus, buttons, and the Input Panel button.



Tap on the icons on the Task Bar to select and modify settings

Status icons display information such as low batteries or when your 751G Computer is connected to a desktop or to the Internet. You can tap on an icon to open the associated setting or program.

Pop-up Menus

With pop-up menus, you can quickly choose an action for an item.

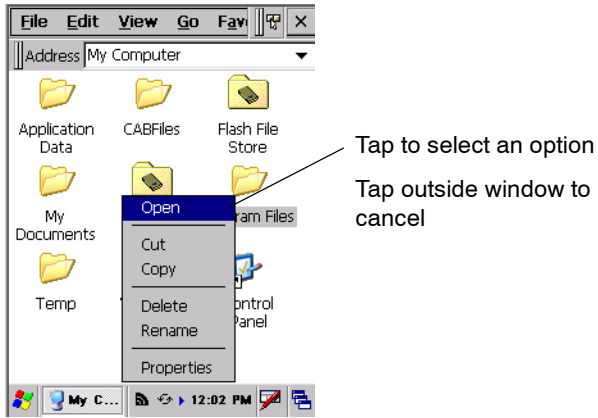

Entering Information into Your 751G Computer

You can enter information in any program on your 751G Computer by typing on the soft keypad or by using one of the on-screen input options, such as Block Recognizer. For more information regarding the options shown in the following pop-up menu, refer to the *751G Computer with Alphanumeric Keypad User's Manual* (p/n: 961-054-038).

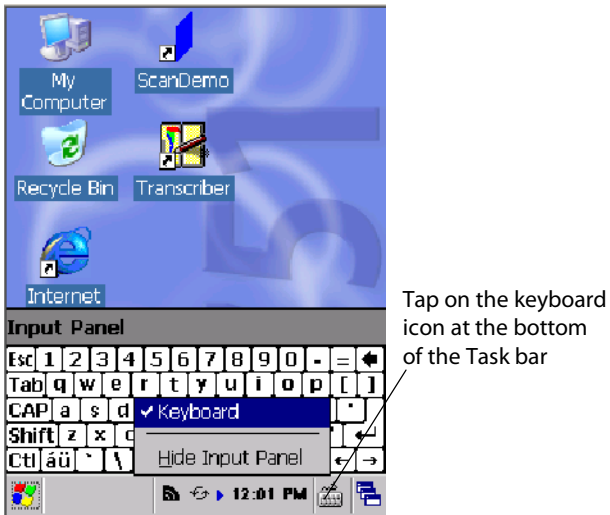

Warm Resetting Your 751G Computer

A warm reset may be necessary to correct conditions where an application stops responding to the system. It does, however, cause all running programs to be unloaded.

- Press and hold the **(I/O)** key for about 10 seconds. Your mobile computer continues from the screen you were at before you rebooted.

Cold Resetting Your 751G Computer

In some cases where the 751G Computer completely stops responding, it may become necessary to perform a Cold Reset. Because cold resetting may result in data loss, it is not recommended unless all other recovery methods have failed.

Cold resetting deletes all programs and data stored in RAM including the Object Store. Ensure that data is backed up to the Host PC or a Storage Card before cold resetting.

- 1 Release the lower clip of the hand strap.
- 2 Remove the battery pack.
- 3 Press the Reset button.

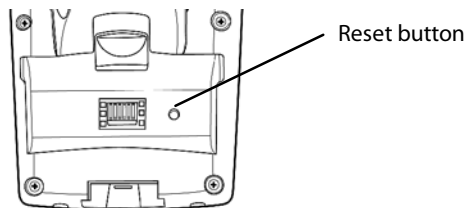

- 4 Reinstall the battery pack.

Troubleshooting

751G Computer does not respond when connected to a power supply.

Check to ensure that your AC adapter or dock is plugged in and that it is making good contact with your mobile computer.

751G Computer will not turn On when key is pressed

The battery may be low and need recharging.

The Power Status LED starts blinking

The Power Status LED informs you of the status of your battery pack when it is connected to a charging device. See page 10 for the LED explanations.

751G Computer will not power up, screen is blank

The Battery may be *critically low*. Ensure that your computer has been on a charger for at least five minutes, then remove from the dock and press the  button. The display will then be active. Continue to charge your mobile computer for 3 hours to ensure that the battery is fully charged.

751G Computer will not turn On when placed in a dock

Ensure that the dock is plugged in and your computer is securely seated in the dock.

751G Computer shuts down during operation

You may have a very low battery, try recharging the battery.

751G Computer does not turn Off

May not turn Off when it is processing data. If this condition continues for a long period of time it will run down the battery unless it is connected to external power.

In the rare event that your 751G Computer locks up, do a Warm Reset and if that doesn't resolve the problem then do a Cold Reset. See page 16 for Cold Reset details.

751G Computer takes a long time to boot up after a reset

Normal time is between 30-45 seconds. If it takes longer than this, contact support personnel.

Cleaning Your 751G Computer

Periodic cleaning helps maintain the appearance of your 751G Computer. When cleaning your 751G Computer, inspect the keyboard, covers, display, and connectors for obvious signs of damage or wear.



Note: Do not use abrasive cleaning compounds, ketonic solvents (acetone or ketone) or aromatic solvents (toluene or xylene) to clean any part of your 751G Computer. These solutions cause permanent damage.



Note: Never pour cleaners directly on the display or the case. Instead put the cleanser on a soft cloth and gently wipe the case.

Case and Display

We recommend cleaning the exterior of your mobile computer using a soft cloth dampened with MICRO-CLEAN II cleanser, made by Foresight International, Inc. 4887 F Street, Omaha, NE 68127-0205 (phone: 1-800-637-1344).

Where to Find More Information

- *Intermec Computer Command Reference Manual* (p/n: 073529) which contains the 751G software developer's kit (SDK). The SDK is used by application developer's to access features such as radios and scanners.
- *751G Computer with Alphanumeric Keypad User's Manual* p/n 961-054-038. This manual contains documentation and the utilities for your unit. You would use the utilities to set up and configure your mobile computer.
- Intermec web site to download 751G mobile computer documents in PDF format. Go to <http://www.intermec.com>. This site also contains the Intermec technical knowledge 'Knowledge Central' and you can also request technical support.

Radio Use Safety Precautions

The following safety precautions must be observed during all phases of the operation, usage, service or repair of any mobile computer incorporating a radio. Failure to comply with these precautions violates safety standards of design, manufacture and intended use of the product.

Intermec assumes no liability for customer failure to comply with these precautions.

When in a hospital or other health care facility, observe the restrictions on the use of mobile devices. Turn your mobile computer off, if instructed to do so by the guidelines posted in sensitive areas. Medical equipment may be sensitive to RF energy.

The operation of cardiac pacemakers, other implanted medical equipment and hearing aids can be affected by interference from mobile computers placed close to the device. If in doubt about potential danger, contact the physician or the manufacturer of the device to verify that the equipment is properly shielded. Pacemaker patients are advised to keep their mobile computer away from the pacemaker, while it is on.

Turn off the mobile computer before boarding an aircraft. Make sure it cannot be switched on inadvertently.

The operation of wireless appliances in an aircraft is forbidden to prevent interference with communications systems. Failure to observe these instructions may lead to the suspension or denial of cellular services to the offender, legal action, or both.

Do not operate the mobile computer in the presence of flammable gases or fumes. Turn off the mobile computer when you are near gas stations, fuel depots, chemical plants or where blasting operations are in progress. Operation of any electrical equipment in potentially explosive atmospheres can constitute a safety hazard.

Your mobile computer receives and transmits radio frequency energy while turned on. Remember that interference can occur if it is used close to TV sets, radios, computers or inadequately shielded equipment.

Follow any special regulations and always turn off the mobile computer wherever forbidden, or when you suspect that it may cause interference or danger.

Road safety comes first! Do not use a mobile computer when driving a vehicle, unless it is securely mounted in a holder for handsfree operation. Before making a call with a cellular mobile computer, park the vehicle.

End User License Agreement

Microsoft Windows CE.Net

IMPORTANT -- READ CAREFULLY: You have acquired a device ("DEVICE") that includes software licensed by Intermec Technologies Corporation from Microsoft Licensing Inc. or its affiliates ("MS"). Those installed software products of MS origin, as well as associated media, printed materials, and "online" or electronic documentation ("SOFTWARE") are protected by international intellectual property laws and treaties. The SOFTWARE is licensed, not sold. All rights reserved. SOFTWARE includes software already installed on the DEVICE ("DEVICE Software") and MS software contained on the CD-ROM disk ("Companion CD").

IF YOU DO NOT AGREE TO THIS END USER LICENSE AGREEMENT ("EULA"), DO NOT USE THE DEVICE OR COPY THE SOFTWARE. INSTEAD, PROMPTLY CONTACT INTERMEC TECHNOLOGIES CORPORATION FOR INSTRUCTIONS ON RETURN OF THE UNUSED DEVICE(S) FOR A REFUND. ANY USE OF THE SOFTWARE, INCLUDING BUT NOT LIMITED TO USE ON THE DEVICE, WILL CONSTITUTE YOUR AGREEMENT TO THIS EULA (OR RATIFICATION OF ANY PREVIOUS CONSENT).
GRANT OF SOFTWARE LICENSE.

This EULA grants you the following license:

- **DEVICE Software.** You may use the DEVICE Software as installed on the DEVICE.
- **COMPANION CD.** A Companion CD is included with your DEVICE, and you may install and use the Microsoft® ActiveSync® 3.7 component on one (1) or more computers to exchange information with one (1) or more computing devices that contain a compatible version of the Microsoft® Windows CE.Net software operating system. For other software component(s) contained on the Companion CD, you may install and use such components only in accordance with the terms of the printed or online end user license agreement(s) provided with such component(s). In the absence of an end user license agreement for particular component(s) of the Companion CD, you may install and use only one (1) copy of such component(s) on the DEVICE or a single computer with which you use the DEVICE.
- **Microsoft® Outlook® 2002.** If Microsoft Outlook 2002 is included with your DEVICE, the following terms apply to your use of Microsoft Outlook 2002: (i) regardless of the information contained in the "Software Installation and Use" section of the online EULA you may install one (1) copy of Microsoft Outlook 2002 on one (1) computer to use, exchange data, share data, access and interact with the DEVICE, and (ii) the EULA for Microsoft Outlook 2002 is between Intermec Technologies Corporation and the end user - not between the PC manufacturer and end user.
- **Security Updates/Digital Rights Management.** Content providers are using the digital rights management technology contained

in this SOFTWARE ("DRM") to protect the integrity of their content ("Secure Content") so that their intellectual property, including copyright, in such content is not misappropriated. Portions of this SOFTWARE and third party applications such as media players use DRM to play Secure Content ("DRM Software"). If the DRM SOFTWARE's security has been compromised, owners of Secure Content ("Secure Content Owners") may request that MS revoke the DRM SOFTWARE's right to copy, display and/or play Secure Content. Revocation does not alter the DRM SOFTWARE's ability to play unprotected content. A list of revoked DRM SOFTWARE is sent to your computer whenever you download a license for Secure Content from the Internet. You therefore agree that MS may, in conjunction with such license, also download revocation lists onto your computer on behalf of Secure Content Owners. MS will not retrieve any personally identifiable information, or any other information, from your computer by downloading such revocation lists. Secure Content Owners may also require you to upgrade some of the DRM components in this SOFTWARE ("DRM Upgrades") before accessing their content. When you attempt to play such content, MS DRM SOFTWARE will notify you that a DRM Upgrade is required and then ask for your consent before the DRM Upgrade is downloaded. Third party DRM Software may do the same. If you decline the upgrade, you will not be able to access content that requires the DRM Upgrade; however, you will still be able to access unprotected content and Secure Content that does not require the upgrade.

DESCRIPTION OF OTHER RIGHTS AND LIMITATIONS.

- **Speech/Handwriting Recognition.** If the SOFTWARE includes speech and/or handwriting recognition component(s), you should understand that speech and handwriting recognition are inherently statistical processes and that errors can occur in the component's recognition of your handwriting, and the final conversion into text. Neither Intermec Technologies Corporation nor its suppliers shall be liable for any damages arising out of errors in the speech and handwriting recognition process.
- **Limitations on Reverse Engineering, Decompilation and Disassembly.** You may not reverse engineer, decompile, or disassemble the SOFTWARE, except and only to the extent that such activity is expressly permitted by applicable law notwithstanding this limitation.
- **Single DEVICE.** The DEVICE Software is licensed with the DEVICE as a single integrated product. The DEVICE Software installed in read only memory ("ROM") of the DEVICE may only be used as part of the DEVICE.
- **Single EULA.** The package for the DEVICE may contain multiple versions of this EULA, such as multiple translations and/or multiple media versions (e.g., in the user documentation and in the software). Even if you receive multiple versions of the EULA, you are licensed to use only one (1) copy of the DEVICE Software.
- **NOTICE REGARDING THE MPEG-4 VISUAL STAN-**

DARD. The SOFTWARE may include MPEG-4 visual decoding technology. MPEG LA, L.L.C. requires the following notice:

- USE OF THIS SOFTWARE IN ANY MANNER THAT COMPLIES WITH THE MPEG 4 VISUAL STANDARD IS PROHIBITED, EXCEPT FOR USE DIRECTLY RELATED TO (A) DATA OR INFORMATION (i) GENERATED BY AND OBTAINED WITHOUT CHARGE FROM A CONSUMER NOT THEREBY ENGAGED IN A BUSINESS ENTERPRISE, AND (ii) FOR PERSONAL USE ONLY; AND (B) OTHER USES SPECIFICALLY AND SEPARATELY LICENSED BY MPEG LA, L.L.C.

If you have questions regarding this Notice, please contact MPEG LA, L.L.C., 250 Steele Street, Suite 300, Denver, Colorado 80206; Telephone 303 331.1880; FAX 303 331.1879

- **NO RENTAL.** Except if specifically authorized by Intermec Technologies Corporation for leased hardware, you may not rent, lease, or lend the SOFTWARE.

- **LEASED HARDWARE.** In the event that you receive the DEVICE under the terms of a lease from Intermec Technologies Corporation or Intermec Technologies Corporation's third-party representative, the following additional terms shall apply: (i) you may not transfer the SOFTWARE to another user as part of the transfer of the DEVICE, whether or not a permanent transfer of the SOFTWARE with the DEVICE is otherwise allowed in this EULA; (ii) your rights with respect to any SOFTWARE upgrades shall be as determined by the lease you signed for the DEVICE; and (iii) you may not use the SOFTWARE after your lease terminates, unless you purchase the DEVICE from Intermec Technologies Corporation.]

- **Software Transfer.** You may permanently transfer all of your rights under this EULA only as part of a sale or transfer of the DEVICE, provided you retain no copies, you transfer all of the SOFTWARE (including all component parts, the media and printed materials, any upgrades, this EULA and, if applicable, the Certificate(s) of Authenticity), and the recipient agrees to the terms of this EULA. If the SOFTWARE is an upgrade, any transfer must include all prior versions of the SOFTWARE.

- **Termination.** Without prejudice to any other rights, Intermec Technologies Corporation or MS may terminate this EULA if you fail to comply with the terms and conditions of this EULA. In such event, you must destroy all copies of the SOFTWARE and all of its component parts.

UPGRADES AND RECOVERY MEDIA.

- **DEVICE Software.** If the DEVICE Software is provided by Intermec Technologies Corporation separate from the DEVICE on media such as a ROM chip, CD ROM disk(s) or via web download or other means, and is labeled "For Upgrade Purposes Only" you may install one (1) copy of such DEVICE Software onto the DEVICE as a replacement copy for the existing DEVICE Software, and use it in accordance with this EULA including any additional EULA terms accompanying the upgrade DEVICE Software.

· **COMPANION CD.** If any software component(s) is provided by Intermec Technologies Corporation separate from the DEVICE on CD ROM disk(s) or via web download or other means, and labeled "For Upgrade Purposes Only", you may (i) install and use one (1) copy of such component(s) on the computer(s) you use to exchange data with the DEVICE as a replacement copy for the existing Companion CD component(s).

· **COPYRIGHT.** All title and intellectual property rights in and to the SOFTWARE (including but not limited to any images, photographs, animations, video, audio, music, text and "applets," incorporated into the SOFTWARE), the accompanying printed materials, and any copies of the SOFTWARE, are owned by MS or its suppliers (including Microsoft Corporation). You may not copy the printed materials accompanying the SOFTWARE. All title and intellectual property rights in and to the content which may be accessed through use of the SOFTWARE is the property of the respective content owner and may be protected by applicable copyright or other intellectual property laws and treaties. This EULA grants you no rights to use such content. All rights not specifically granted under this EULA are reserved by MS and its suppliers (including Microsoft Corporation).

EXPORT RESTRICTIONS. You acknowledge that SOFTWARE is subject to U.S. export jurisdiction. You agree to comply with all applicable international and national laws that apply to the SOFTWARE, including the U.S. Export Administration Regulations, as well as end-user, end-use and destination restrictions issued by U.S. and other governments. For additional information, see <http://www.microsoft.com/exporting/>.

PRODUCT SUPPORT. Product support for the SOFTWARE is not provided by MS, its parent corporation, Microsoft Corporation, or their affiliates or subsidiaries. For product support, please refer to Intermec Technologies Corporation support number provided in the documentation for the DEVICE. Should you have any questions concerning this EULA, or if you desire to contact Intermec Technologies Corporation for any other reason, please refer to the address provided in the documentation for the DEVICE.

NO LIABILITY FOR CERTAIN DAMAGES. EXCEPT AS PROHIBITED BY LAW, MS SHALL HAVE NO LIABILITY FOR ANY INDIRECT, SPECIAL, CONSEQUENTIAL OR INCIDENTAL DAMAGES ARISING FROM OR IN CONNECTION WITH THE USE OR PERFORMANCE OF THE SOFTWARE. THIS LIMITATION SHALL APPLY EVEN IF ANY REMEDY FAILS OF ITS ESSENTIAL PURPOSE.

FOR APPLICABLE LIMITED WARRANTIES AND SPECIAL PROVISIONS PERTAINING TO YOUR PARTICULAR JURISDICTION, PLEASE REFER TO YOUR WARRANTY BOOKLET INCLUDED WITH THIS PACKAGE OR PROVIDED WITH THE SOFTWARE PRINTED MATERIALS.

Intermec Technologies Corporation

End User License Agreement

- 1 This device contains intellectual property, i.e., software programs that are licensed for the end user customer's use (hereinafter "End User").
- 2 This is not a sale of such intellectual property.
- 3 The End User shall not copy, disassemble or reverse compile the software program.
- 4 THE SOFTWARE PROGRAMS ARE PROVIDED TO THE END USER "AS IS" WITHOUT WARRANTY OF ANY KIND, EITHER EXPRESS OR IMPLIED, INCLUDING, BUT NOT LIMITED TO, WARRANTIES OF MERCHANTABILITY AND FITNESS FOR A PARTICULAR PURPOSE. THE ENTIRE RISK OF THE QUALITY AND PERFORMANCE OF THE SOFTWARE PROGRAM IS WITH YOU.
- 5 COMPANY'S SUPPLIERS SHALL NOT BE HELD TO ANY LIABILITY FOR ANY DAMAGES SUFFERED OR INCURRED BY THE END USER (INCLUDING, BUT NOT LIMITED TO, GENERAL, SPECIFIC, CONSEQUENTIAL OR INCIDENTAL DAMAGES INCLUDING BUSINESS INFORMATION AND THE LIKE), ARISING FROM OR IN CONNECTION WITH THE DELIVERY, USE OR PERFORMANCE OF THE SOFTWARE PROGRAM.

Global Services and Support

Warranty Information

To understand the warranty for your Intermec product, visit the Intermec web site at <http://www.intermec.com> and click **Service & Support**. The Intermec Global Sales & Service page appears. From the **Service & Support** menu, move your pointer over **Support**, and then click **Warranty**.

Web Support

Visit the Intermec web site at <http://www.intermec.com> to download our current manuals in PDF format. To order printed versions of the Intermec manuals, contact your local Intermec representative or distributor.

Visit the Intermec technical knowledge base (Knowledge Central) at <http://intermec.custhelp.com> to review technical information or to request technical support for your Intermec product.

Telephone Support

You can find information on Intermec telephone support services at <http://www.intermec.com/AIT>. To find the correct telephone number for your country, click **Contact**.

Patent Information

This product is protected by one or more patents.

4,553,081	4,709,202	4,845,419	4,916,043
5,195,183	5,216,233	5,218,187	5,218,188
5,227,614	5,241,488	5,278,487	5,322,991
5,331,136	5,331,580	5,349,678	5,397,885
5,371,858	5,373,478	5,410,141	5,488,575
5,500,516	5,504,367	5,508,599	5,530,619
5,567,925	5,568,645	5,592,512	5,598,007
5,617,343	5,627,360	5,657,317	5,671,436
5,684,290	5,777,309	5,579,604	5,805,807
5,818,027	5,821,523	5,828,052	5,831,819
5,834,753	5,841,121	5,844,222	5,883,492
5,883,493	5,886,338	5,889,386	5,898,162
5,969,328	5,986,435	6,075,340	6,109,528
6,158,661	6,234,395	6,244,512	6,330,975
6,431,451	6,497,368	6,538,413	Des. 417,445



This product with an IEEE 802.11b radio installed is Wi-Fi certified for interoperability with other 802.11b wireless LAN devices.



Corporate Headquarters

6001 36th Avenue West
Everett, Washington 98203
U.S.A.

tel 425.348.2600

fax 425.355.9551

www.intermec.com

© 2003-2005 Intermec Technologies Corporation. All rights reserved.

751G Alphanumeric Mobile Computer Quick Start Guide



P/N: 930-102-001