

4420 and 4440 Printer Self-Strip/Batch Takeup



A **UNOVA** Company

Intermec Technologies Corporation
6001 36th Avenue West
P.O. Box 4280
Everett, WA 98203-9280

U.S. service and technical support: 1-800-755-5505
U.S. media supplies ordering information: 1-800-227-9947

Canadian service and technical support: 1-800-688-7043
Canadian media supplies ordering information: 1-800-268-6936

Outside U.S. and Canada: Contact your local Intermec service supplier.

The information contained herein is proprietary and is provided solely for the purpose of allowing customers to operate and/or service Intermec manufactured equipment and is not to be released, reproduced, or used for any other purpose without written permission of Intermec.

Information and specifications in this manual are subject to change without notice.

© 1998 by Intermec Technologies Corporation
All Rights Reserved

The word Intermec, the Intermec logo, JANUS, IRL, TRAKKER, Antares, Adara, Duratherm, EZBuilder, Precision Print, PrintSet, Virtual Wedge, and CrossBar are either trademarks or registered trademarks of Intermec Technologies Corporation. Throughout this manual, trademarked names may be used. Rather than put a trademark (TM or ®) symbol in every occurrence of a trademarked name, we state that we are using the names only in an editorial fashion, and to the benefit of the trademark owner, with no intention of infringement.

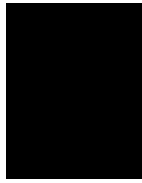

Introduction to the Self-Strip/Batch Takeup Option

The self-strip/batch takeup option enables the 4420 or 4440 printer to operate in Self-Strip or Batch mode. When you use the printer in Self-Strip mode, the printer strips each label off of the backing as it leaves the printer. When you use the printer in Batch mode, the printer can collect an entire roll of media on the media takeup hub.

This manual explains how to:

- load media to use self-strip.
- load media to use batch takeup.
- configure the printer for Self-Strip or Batch mode.
- clean the self-strip roller and sensors.
- troubleshoot the self-strip/batch takeup option.

Loading Media for Self-Strip

Self-strip allows you to apply labels as soon as they are printed by having the printer peel the media backing away from individual labels one at a time. The label taken sensor signals the printer that a label has been removed so that it will print the next label.

For optimal performance, load your printer with Intermec self-strip media. Fanfold media is not recommended because the backing might tear along the perforation.

Note: After the printer prints the last label and passes the end of the media roll through the printhead, the takeup hub will turn for a few revolutions before stopping.

To load media for self-strip

1. Turn off the printer.
2. Load media into the printer, leaving the media cover off. For help, see your printer user's manual.
3. Turn the head lift lever clockwise to raise the printhead.

4420 and 4440 Printer Self-Strip/Batch Takeup User's Manual

4. Open the media access door.

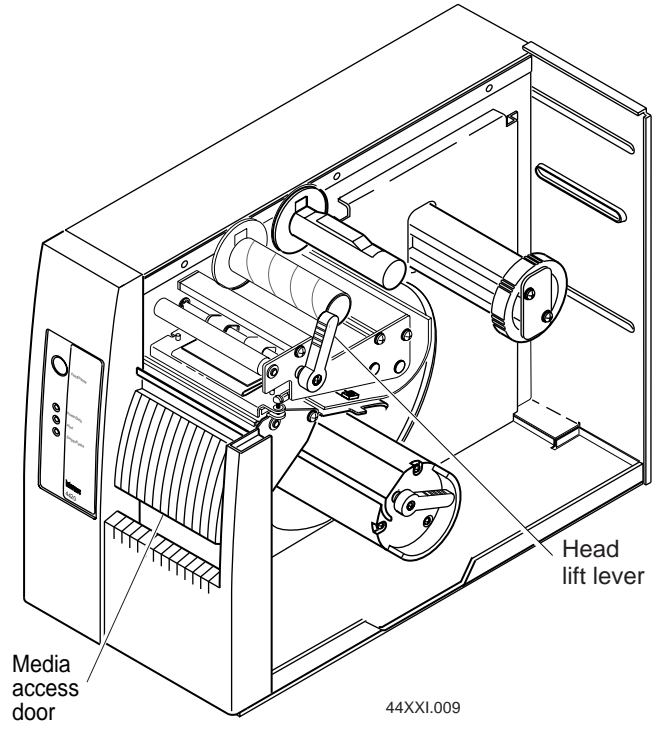

5. Route the media below the self-strip roller.

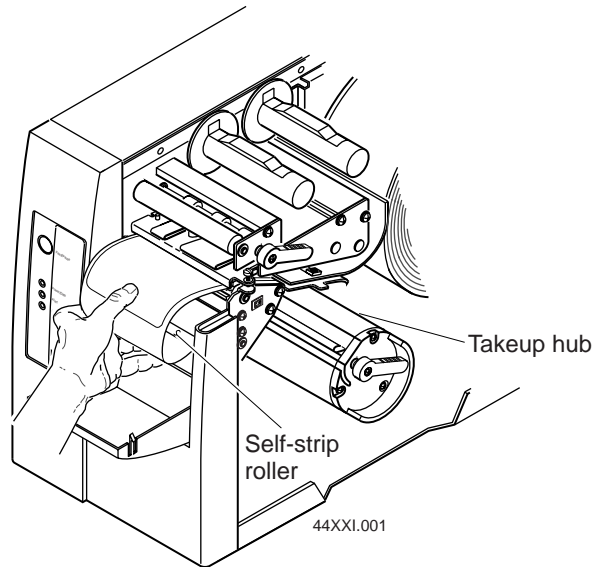



6. Place the end of the media in the media slot.

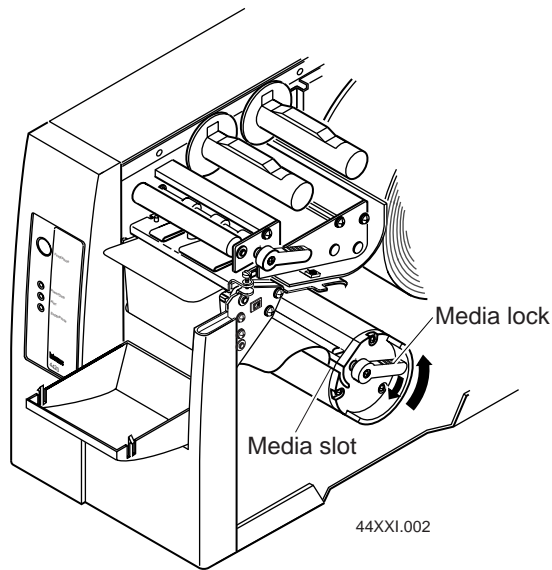

7. Turn the media lock clockwise to lock the media in place.
8. Turn the takeup hub counterclockwise until the media fits snugly against the takeup hub.
9. Turn the head lift lever counterclockwise to secure the printhead.
10. Close the media access door and replace the media cover.
11. On the back of the printer, turn on DIP switch number 8 on the top bank of DIP switches.

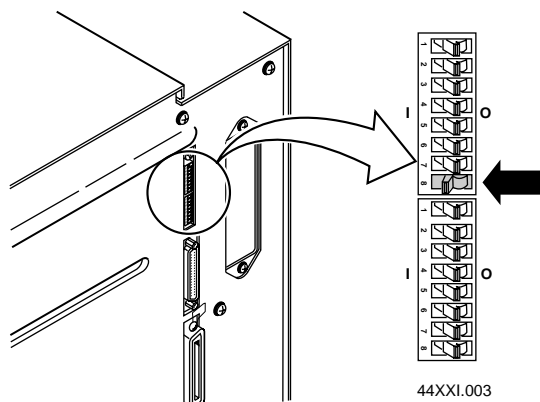

12. Turn on the printer.
13. Configure the printer for Self-Strip mode. For help, see "Configuring Your Printer for Self-Strip or Batch" later in this document.

Loading Media for Batch Takeup

Use batch takeup to collect printed media onto the takeup hub. The media can spool directly onto the takeup hub or onto a core.

Note: After the printer prints the last label and passes the end of the media roll through the printhead, the takeup hub will turn for a few revolutions before stopping.

To load media for batch takeup

1. Turn off the printer
2. Load media into the printer, leaving the media cover off. For help, see your user's manual.
3. Turn the head lift lever clockwise to raise the printhead.
4. Hook the batch guide over the top of the media access door and push down on the bottom of the batch guide to latch it into place.

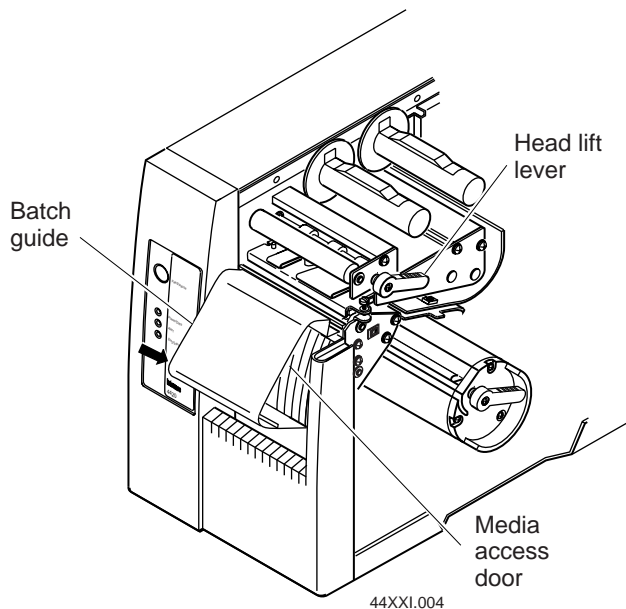

5. Route the media around the batch guide.

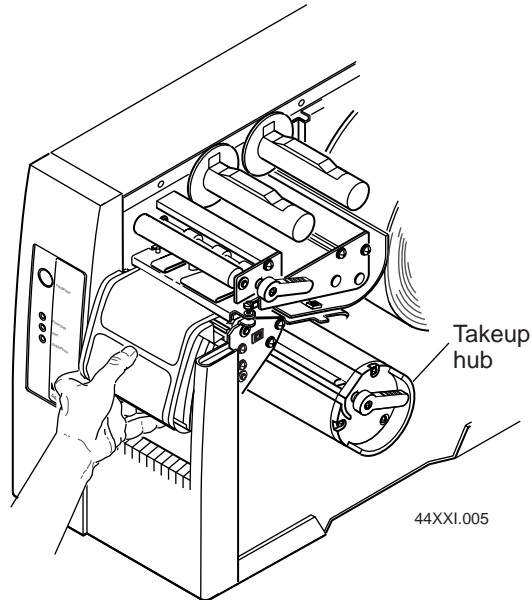

6. To have the media rolled onto the takeup hub, place the end of the media in the media slot and turn the media lock clockwise to lock the media into place.

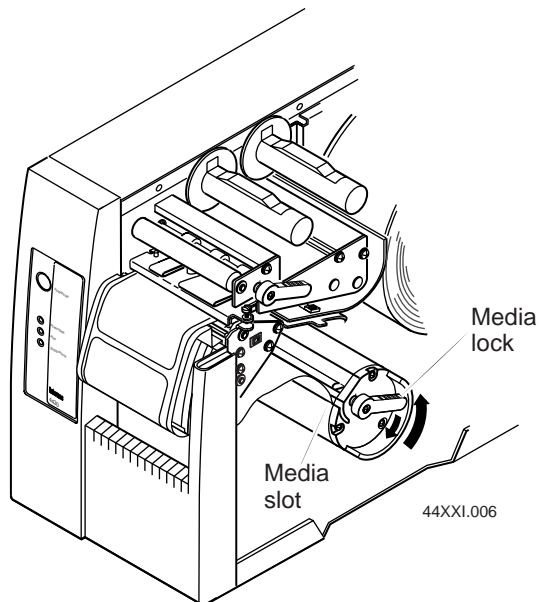

To have the media rolled onto an empty core, place the core onto the takeup hub, turn the media lock clockwise to lock the core into place, and tape the end of the media to the core.

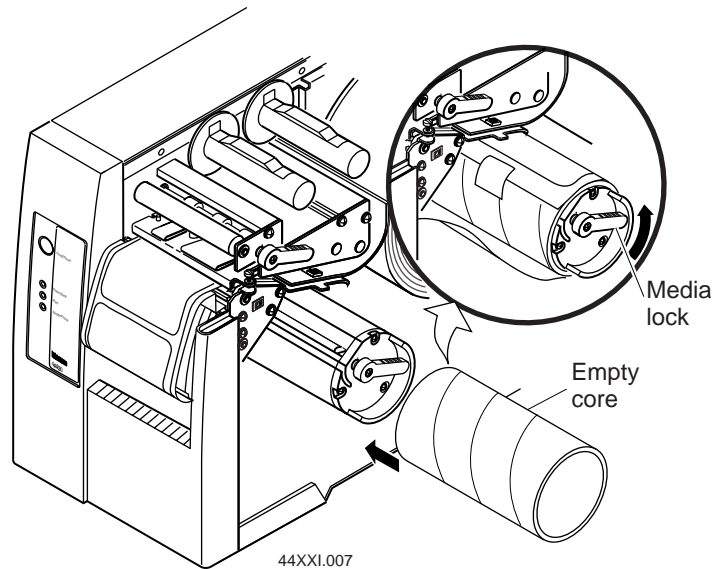

7. Turn the media takeup hub counterclockwise until the media fits snugly against the takeup hub.
8. Turn the head lift lever counterclockwise to secure the printhead.
9. Replace the media cover.
10. In the back of the printer, turn on DIP switch number 8 on the top bank of DIP switches.

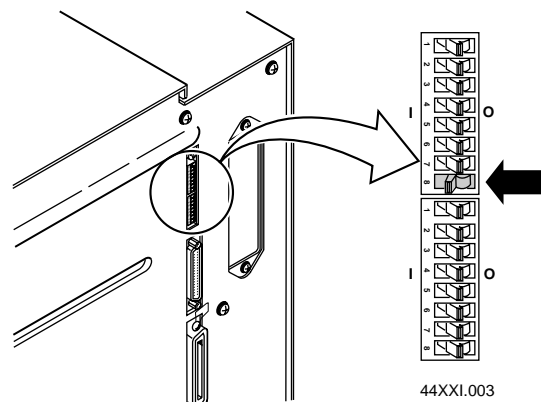

11. Turn on the printer.
12. Configure the printer for batch. For help, see "Configuring Your Printer for Self-Strip or Batch" later in this document.

Configuring Your Printer for Self-Strip or Batch

The following procedure explains how to use PrintSet to enable either Self-Strip or Batch mode. To operate in Self-Strip mode, the media must be loaded onto the takeup hub. The printer can operate in Batch mode without the media being loaded onto the takeup hub; the printed media will collect in front of the printer instead of into a roll on the takeup hub.

This procedure also explains setting the label width and configuring the printer for a hot and humid environment.

To configure your printer for Self-Strip or Batch mode

1. Connect the printer to your PC and start PrintSet.

Note: Under the Printer Select menu, check that PrintSet is set up for your printer (4420 or 4440). To customize the configuration for your printer, see the Help menu.

2. Click the Paper Handling button.



3. From the Paper Handling dialog box, select Self-Strip or Batch.

4. If you work in a hot or humid environment (temperature at or above 104°F [40°C] and humidity at or above 90 percent), select the Hot/Humid Environment box.
5. Choose OK.
6. Click the Paper Type button.



7. From the Paper Type dialog box, set the Label Width to match the width of the media in the printer. The default setting is 4 inches.

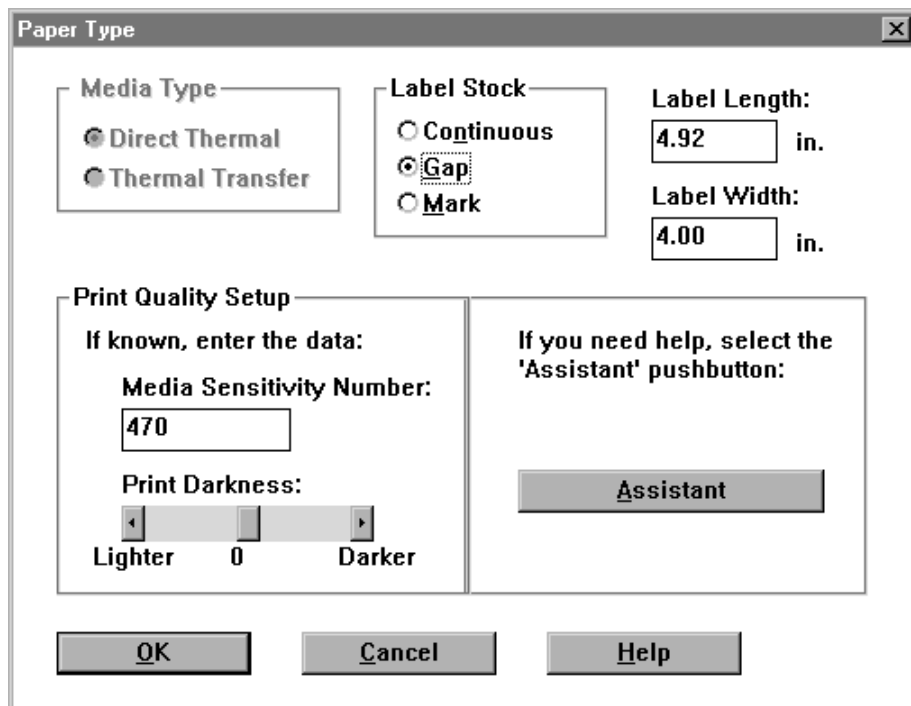

8. For Self-Strip mode, make sure you select Gap under Label Stock.
9. Choose OK.

Note: If you want to change other configuration settings, you should do so before going to Step 10. For help changing the configuration, see the Help menu.

10. Click the Send Command button.



A message box appears asking if you want to overwrite the current printer settings. Choose Send to enable self-strip or batch with the configuration you have created.

11. Exit PrintSet.

Cleaning the Self-Strip Roller and Sensors

The self-strip roller should be cleaned after every fifth media roll or as needed to prevent the accumulation of dirt, debris, and adhesive residue. The label taken sensor and takeup hub sensor should be cleaned after every tenth media roll. Clean more often in environments that are harsh or dusty.



Caution

Do not use sharp objects such as knives or screwdrivers to scrape the self-strip roller clean. Cleaning with sharp objects will damage the self-strip roller. Clean with only a cotton swab, or a clean, lint-free cloth or tissue damp with isopropyl alcohol.

Conseil

N'utilisez pas d'objets pointus tels que couteaux ou tournevis pour nettoyer la barre de roulement. Nettoyer avec des objets pointus endommagera la barre de roulement. Nettoyez-la seulement avec de la ouate ou avec un linge propre et libre de peluches, humecté avec de l'alcool d'isopropyl.

To clean the self-strip roller and sensors

1. Turn off the printer.
2. Unplug the printer power supply.
3. Pull the bottom of the media cover away from the base of the printer, lift the front of the media cover upward to release it from the printer frame, and lift the media cover away from the top of the printer.
4. Unlock and remove the media from the media slot. If the media is wrapped all the way around the takeup hub, cut the media close to the takeup hub or before the last printed label and remove the media wrapped around the takeup hub.

5. Swing the media access door open.
6. Turn the head lift lever clockwise so you can remove the media from the printhead.
7. Roll the media back onto the media roll and remove the media roll.
8. Using a cotton swab or lint-free cloth dampened with isopropyl alcohol, clean the self-strip roller and label taken sensor.

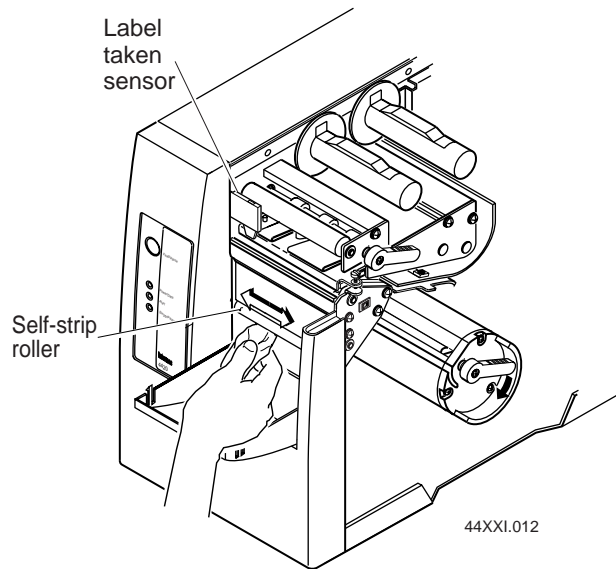

Caution

Never use thinner or other volatile solvent for cleaning.

Conseil

N'utilisez jamais de térébenthine ou d'autre solvant volatil pour nettoyer.

9. Blow dust out of the takeup hub sensor with compressed air.

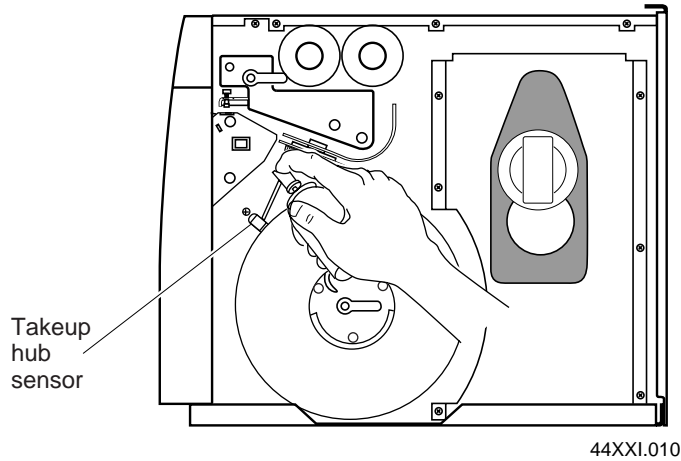

10. Blow dust out of the flange holes with compressed air.

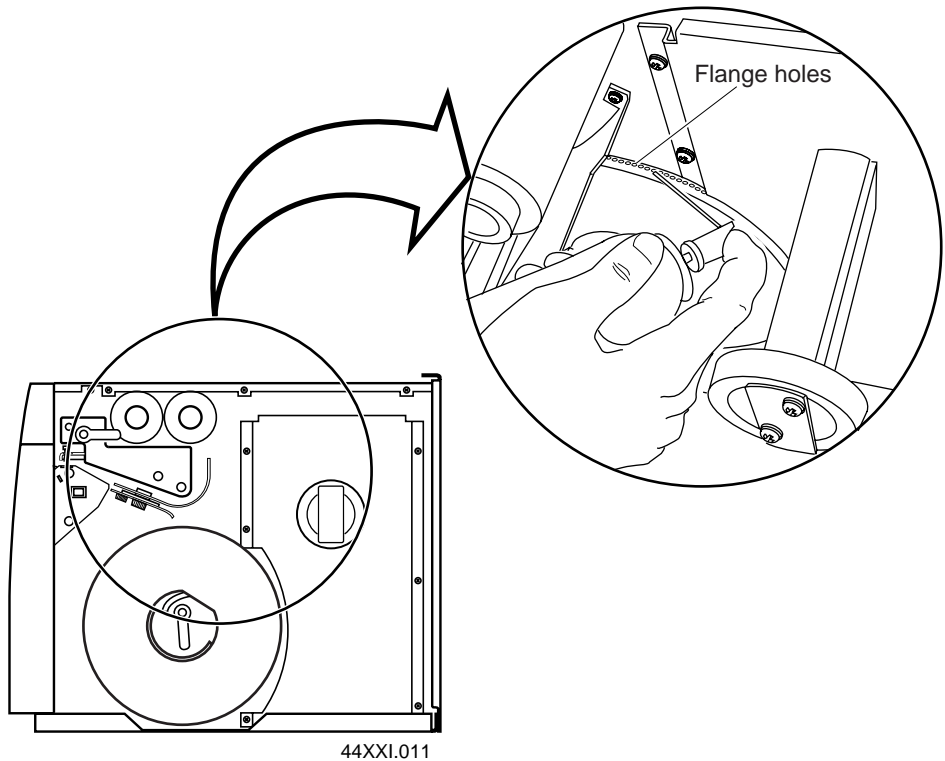

11. Reload the media, route the media below the self-strip roller, insert it into the media slot, and lock the media into place with the media lock.

12. Turn the takeup hub counterclockwise until the media fits snugly against the takeup hub.
13. Turn the head lift lever counterclockwise to secure the printhead.
14. Close the media access door and replace the media cover.
15. Plug in the printer power supply.
16. Turn on the printer.

Troubleshooting

This section describes some possible problems and solutions. If the solutions do not solve the problems, try the troubleshooting solutions in your printer user's manual or call your Intermec service technician. In the USA, call 1-800-755-5505. In Canada, call 1-800-668-7043.

Symptom	Possible Cause	Solution
While using self-strip, labels do not strip off the backing.	High temperature or humidity environment.	In PrintSet, open the Paper Handling dialog box and select Hot/Humid Environment.
	Printer is loaded with media not suitable for self-strip.	Load Intermec self-strip specified media.
	Self-strip roller is dirty.	Clean the self-strip roller.
	The label width is set incorrectly.	In PrintSet, open the Paper Type dialog box and set the Label Width to the width of the media in the printer.
Media is too loose or too tight on the takeup hub.	The label width is set incorrectly.	In PrintSet, open the Paper Type dialog box and set the Label Width to the width of the media in the printer.
	The media support is not in the correct position.	Make sure the media support is positioned close to the media roll. For help, see your printer user's manual.
At the end of the media roll, the takeup hub does not stop running.	The takeup hub sensor and flange are dirty.	Clean the takeup hub sensor and the flange holes.
The takeup hub does not rotate in either Self-Strip or Batch mode.	DIP switch number 8 is off.	On the back of the printer, turn on DIP switch number 8 on the top bank of DIP switches and cycle power.

Troubleshooting (continued)

Symptom	Possible Cause	Solution
While using batch takeup, the printer prints one label and stops.	The printer is set for Self-Strip mode.	In PrintSet, open the Paper Handling dialog box and select Batch.
While using self-strip, the label falls off or is hard to remove.	The label rest point is set incorrectly.	In PrintSet, open the Paper Handling dialog box and slide the Rest Adjustment backward or forward.
The media is slipping between the roller and printhead and the print quality is poor.	The printhead pressure is set incorrectly for the media width.	Adjust the printhead pressure with the bias screw. For help, see your printer user's manual.
The media does not retract.	Label Retract is disabled.	In PrintSet, open the Paper Handling dialog box and select Enable Label Retract.
The image is printed in the gap between the labels.	Continuous mode is enabled.	In PrintSet, open the Paper Type dialog box and select Gap.
	Label length is set too long.	In PrintSet, open the Paper Type dialog box and shorten the Label Length.
Media becomes slack between the printing area and the takeup hub.	The takeup hub sensor and flange are dirty.	Clean the takeup hub sensor and the flange holes.
	The printhead pressure is set incorrectly for the media width.	Adjust the printhead pressure with the bias screw. For help, see your printer user's manual.
The media tears while attached to the takeup hub.	The label width or the hot/humid environment are not set correctly.	In PrintSet, open the Paper Type dialog box and set the Label Width to the width of the media in the printer. In the Paper Handling dialog box, check that Hot/Humid Environment is set or disabled depending on the conditions the printer is operating in.
While using self-strip, the labels keep printing before the labels can be removed.	The label taken sensor is dirty.	Clean the label taken sensor.
	The printer is not set for Self-Strip mode.	In PrintSet, open the Paper Handling dialog box and select Self-Strip.
When not using self-strip or batch takeup, the takeup hub turns.	The self-strip/batch takeup option is enabled.	On the back of the printer, turn off DIP switch number 8 on the top bank of DIP switches and cycle power.

Specifications

This section describes the specifications for a 4420 or 4440 printer with the self-strip/batch takeup option.

Parameter	Minimum	Maximum
Label Peel Release	0.35 ounce (10 g)	1.75 ounces (50 g)
Media Stiffness	0.0035 ounce (100 mg)	N/A
Label Backing Weight	N/A	40 pounds (18 kg)
Label Width	0.65 inch (13 mm)	4.4 inches (11.18 cm)
Label Thickness (including backing)	0.0059 inch (0.15 mm)	0.012 inch (0.30 mm)
Label Length	1.0 inch (25.4 mm)	24 inches (60.96 cm)
Temperature	50°F (10°C)	104°F (40°C)
Humidity	10%	90%
Print Speed	2 inches per second (51 mm per second)	8 inches per second (203 mm per second)

The following media types are not recommended for use in Self-Strip mode:

- Kindura
- Syntran
- 2Mil polyester
- Some thermal media
- Removable adhesive
- Fanfold media

Note: Format, media size and type, and environmental conditions can affect the performance of self-strip.