



3240

Batch Takeup
Accessory

Instruction Sheet

Parts Provided:

- Batch Takeup Hub
- Media Guide Plate
- Media Clamp

Note: The batch takeup accessory rewinds small batches of labels as they are printed by the 3240 printer. Space inside the printer allows the batch takeup accessory to rewind batches of approximately 1500 inches of media.

Step 1

Install the media guide plate onto the media access door

1. Remove the media cover.
2. Remove the rewriter clasp from the rewriter hub.
3. Install the media guide plate to the front of the media access door.

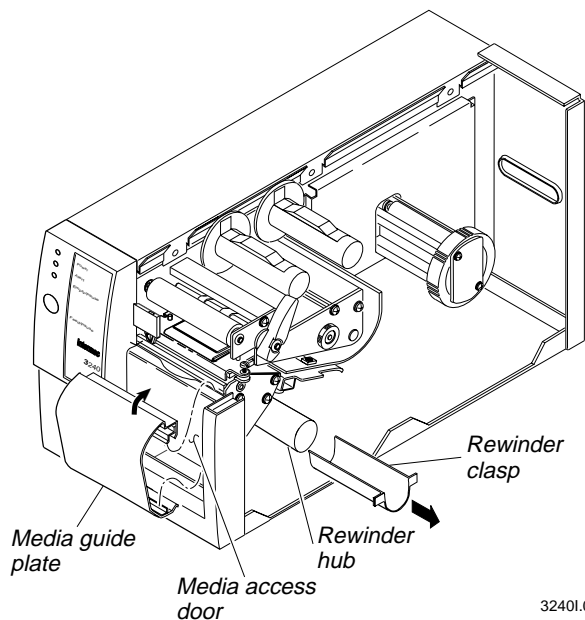

3240I.001



Step 2

Install the batch takeup reel

1. Line up the grooves in the batch takeup hub with the grooves on the rewinder hub.
2. Slide the batch takeup hub all of the way onto the rewinder hub until it snaps in place.

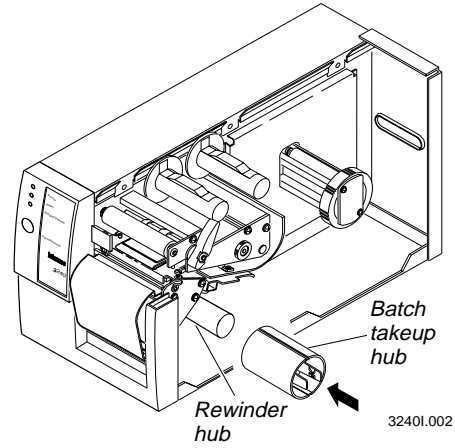

Step 3

Loading the media

1. Refer to “Loading a Roll of Media” in the *3240 User’s Manual* for media loading instructions.
2. Pull at least 12 inches of media out beyond the printhead.
3. Route the media around the media guide plate and through the opening in the media access door.
4. Wind the media clockwise around the batch takeup reel and install the media clamp onto the batch take up reel.
5. Rotate head lift lever counterclockwise to lower printhead.

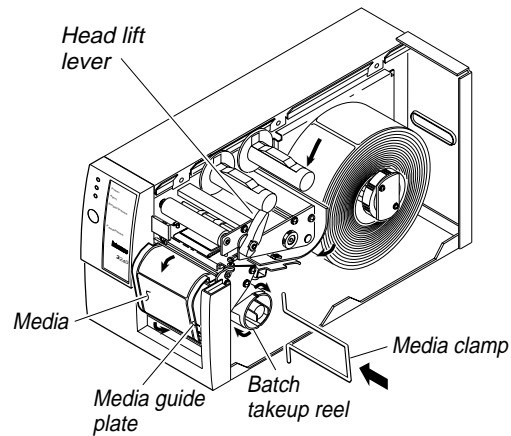

Intermec

Intermec Corporation
6001 36th Avenue West
P.O. Box 4280
Everett, WA 98203-9280
PN 063017-001

32401.003