



Intermec



Installation Instructions

Cutter Kit

(for EasyCoder PF4i
and EasyCoder PF4i
Compact Industrial)

Intermec Technologies Corporation

Corporate Headquarters

6001 36th Ave. W.

Everett, WA 98203

U.S.A.

www.intermec.com

The information contained herein is proprietary and is provided solely for the purpose of allowing customers to operate and/or service Intermec manufactured equipment and is not to be released, reproduced, or used for any other purpose without written permission of Intermec.

Information and specifications in this manual are subject to change without notice and do not represent a commitment on the part of Intermec Technologies Corporation.

© 2005 by Intermec Technologies Corporation. All rights reserved.

EasyCoder and Fingerprint are registered trademarks of Intermec Technologies Corp. The word Intermec and the Intermec logo are trademarks of Intermec Technologies Corp.

Torx is a registered trademark of Camcar Division of Textron Inc.

Throughout this manual, trademarked names may be used. Rather than put a trademark (™) symbol in every occurrence of a trademarked name, we state that we are using the names only in an editorial fashion, and to the benefit of the trademark owner, with no intention of infringement.

Contents

Introduction	iv
Printer Firmware	iv
Installation Kit	iv

1 Description

General Information	2
Media.....	3
Measures and Weight	4

2 Physical Installation

Installation Instructions	6
---------------------------------	---

3 Fingerprint Control

Activating the Cutter.....	10
Controlling the Cut Position.....	10

4 IPL Control

Activating the Cutter.....	12
----------------------------	----

Introduction

This Installation Instructions booklet describes how to install a cutter in an EasyCoder PF4i or PF4i Compact Industrial printer.

The installation instructions also describes how to control the cutter in Intermec Fingerprint and in Intermec Programming Language (IPL).



Warning

This kit must only be physically installed by an authorized service technician. Intermec assumes no responsibility for personal injury or damage to the equipment if the installation is performed by an unauthorized person.



Caution

Take precautions against electrostatic discharges, for example by wearing grounded bracelets.

Printer Firmware

The printer must be fitted with Intermec Fingerprint v8.00 (or later) or IPL v2.00 (or later).

Installation Kit

The Cutter Kit contains:

- One cutter unit
- One tray
- Two cables (one for EasyCoder PF4i, one for EasyCoder F4)
- One cable cover
- Three #T20 Torx screws
- Three washers
- One Installation Instruction booklet

The only tool required for the installation is a #T20 Torx screwdriver.



1 Description

This chapter describes the cutter and provides essential technical data.

General Information

The cutter is a factory-installed or field-installable option for the EasyCoder PF4i and PF4i Compact Industrial printers. The cutter automatically cuts off the media after printing according to instructions in the controlling firmware. The cut off portions of media are presented at the front of the cutter and can be collected on a removable tray.

The cutter can be tilted forward to facilitate media load. As a safety measure, the cutter can only operate when being completely closed.

The cutter prevents an optional label taken sensor from working, even if it not necessary to remove it before fitting the cutter.

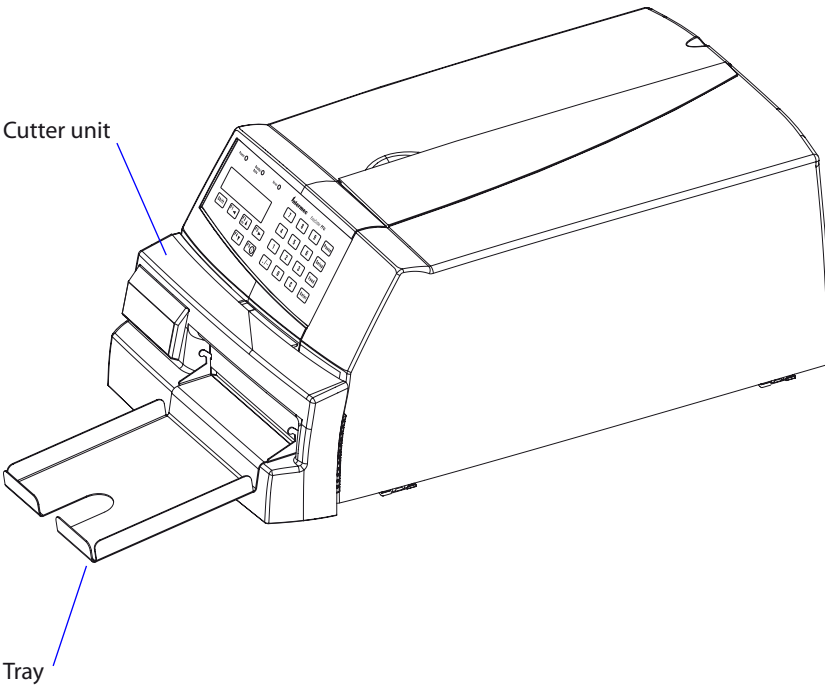

Media

The cutter is primarily intended to cut paper-based media in the form of continuous stock. It is also possible to cut through the liner between labels, but be careful not to cut through the labels themselves, because the adhesive will stick to the cutting blade and may cause malfunction.

Avoid cutting soft plastic-based media.

Minimum media thickness: 78 μ m

Maximum media thickness: 175 μ m

Measures and Weight

When a cutter is installed, the measures of the printer are:

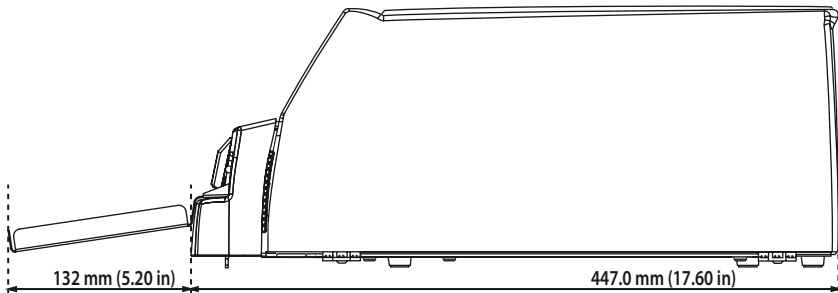
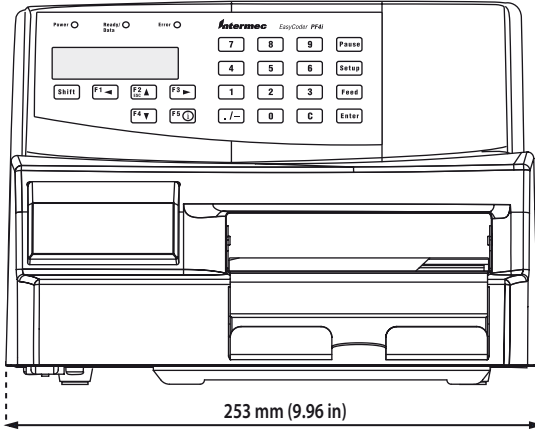

The weight is increased by 1.16 kg (2.56 pounds)

2 Physical Installation

This chapter describes how to physically install the cutter in an EasyCoder PF4i or PF4i Compact Industrial printer.



The electronics compartment contains high voltage components (380V). Always disconnect the power cord before opening the electronics compartment!

Installation Instructions

- Switch off the power and disconnect the power cord and possible communication cables.
- Remove the front/left side moulding that covers the electronics compartment. The moulding is held by three #T20 Torx screws as illustrated below.
- In case of an EasyCoder PF4i Compact Industrial also remove the front door.

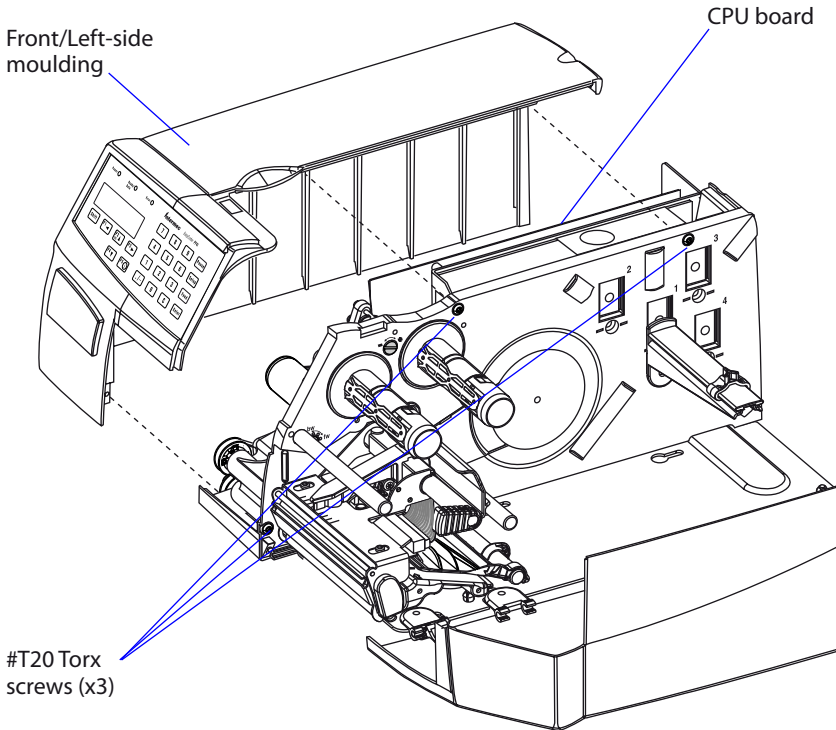

- Lift the moulding straight up so the stiffeners inside the moulding become disengaged from the bottom plate. Then swing out the moulding, taking care not to damage the cable that runs between the console PCB at the front of the moulding and the CPU board. Disconnect the cable from the CPU board and put the moulding aside.
- Close the right-hand door and turn the printer upside down.

- Insert the cutter bracket between the printer's bottom plate and print mechanism so the three threaded bushings on the bracket fits into the corresponding holes in the printer's bottom plate. Fit it using the three #T20 Torx screws and washers included in the kit.
- Choose the cable corresponding to your printer model. Part number 1-974012-001 for PF4-series, and 1-975563-00 for F4-series.
- Route the cutter cable through the slot in the bottom plate as illustrated and connect it firmly to J51 at the lower front corner of the CPU board (marked "FINISHER").
- Pull the cable forward towards the cutter so **the slack comes between printer and cutter**. Lock it in place using the cable cover and the existing #T20 Torx screw as illustrated above.
- Check that the cable is still properly connected to the CPU board.
- Swing the clip aside and connect the cable to the connector on the cutter. Secure the cable with the clip.
- Turn the printer upright again.

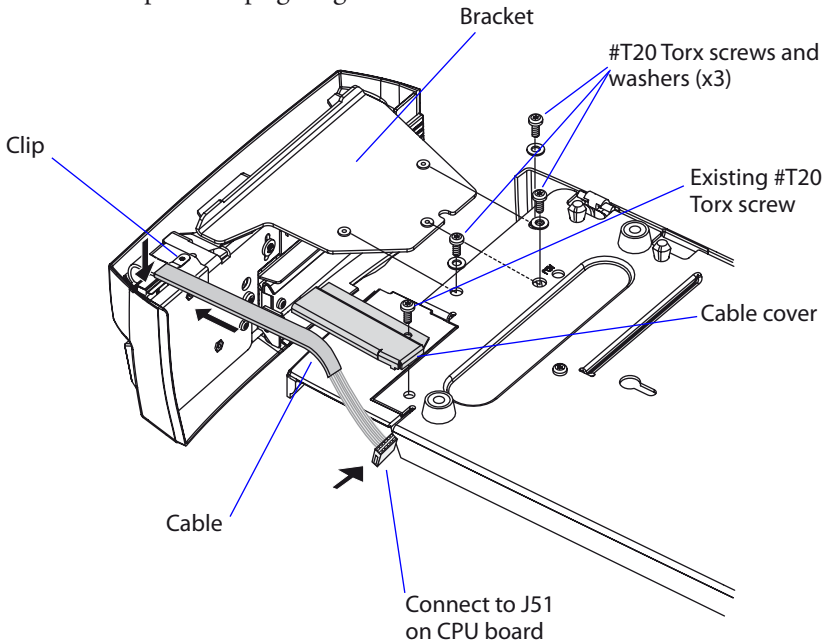

Chapter 2 — Physical Installation

- Put back the front/left side cover. Route the console cable above the ribbon motor (*thermal transfer model only*). Connect the cable to J50 at the top/front corner of the CPU board (marked “console”).
- Connect the power cord and any communication cables. Check that the cutter is closed and switch on the power.

A decorative graphic consisting of two overlapping circles. The larger circle is light gray and partially encloses the smaller circle. The smaller circle is also light gray and has a small dark gray dot at its rightmost point. The number '3' is positioned to the left of the text 'Fingerprint Control', which is in a bold, black, sans-serif font.

3 Fingerprint Control

This chapter describes how to control the cutter in an EasyCoder PF4i or PF4i Compact Industrial when running Intermec Fingerprint v8.00 (or later).

Activating the Cutter

The cutter is activated by CUT or CUT ON statements, see the *Intermec Fingerprint v8.xx*, or the *Intermec Direct Protocol v8.xx* manuals. Application programs may have related facilities for operating the cutter.

Controlling the Cut Position

The edge will cut through the media approx. 33 mm (1.3 inches) in front of the printer's dot line. The relation between the media and the actual cutting position is controlled by the Feed Adjustment parameters in the Setup Mode or in setup files or setup strings.

The following feed adjustment values are recommended for cutting:

Type of Cutting	8 dots/mm printhead	11.81 dots/mm printhead
-----------------	---------------------	-------------------------

Cut between labels

Start adjust:	± 0 dots	0 dots
Stop adjust:	+ 160 dots	+236 dots

Cut between labels and print from leading edge on next label

Start adjust:	- 250 dots	-369 dots
Stop adjust:	+ 160 dots	+236 dots

Cut variable length strip (no liner!)

Start adjust:	- 250 dots	-369 dots
Stop adjust:	+ 275 dots	+406 dots



4 IPL Control

This chapter describes how to control the cutter in an EasyCoder PF4i or PF4i Compact Industrial when running IPL v2.00 (or later).

Activating the Cutter

The cutter is activated in the Setup Mode (Setup/Configuration/Cutter) or by the commands <SO> (cut) and <SI>c1 (enable cutter) or <SI>c0 (disable cutter). Application programs may have related facilities for operating the cutter.



Intermec Technologies Corporation

Corporate Headquarters
6001 36th Avenue West
Everett, WA 98203
U.S.A.

tel +425.348.2600

fax +425.355.9551

www.intermec.com

Cutter Kit (EasyCoder PF4i-series) Installation Instructions



P/N 1-960594-02